

# EESX Hardware Integration Guide

Embedded Ethernet Switch eXtended

Product Family

EESX20 and EESX30



The naming of copyrighted trademarks in this manual, even when not specially indicated, should not be taken to mean that these names may be considered as free in the sense of the trademark and tradename protection law and hence that they may be freely used by anyone.

© 2021 Hirschmann Automation and Control GmbH

Manuals and software are protected by copyright. All rights reserved. The copying, reproduction, translation, conversion into any electronic medium or machine scannable form is not permitted, either in whole or in part. An exception is the preparation of a backup copy of the software for your own use.

The performance features described here are binding only if they have been expressly agreed when the contract was made. This document was produced by Hirschmann Automation and Control GmbH according to the best of the company's knowledge. Hirschmann reserves the right to change the contents of this document without prior notice. Hirschmann can give no guarantee in respect of the correctness or accuracy of the information in this document.

Hirschmann can accept no responsibility for damages, resulting from the use of the network components or the associated operating software. In addition, we refer to the conditions of use specified in the license contract.

You can get the latest version of this manual on the Internet at the Hirschmann product site ([www.hirschmann.com](http://www.hirschmann.com)).

Hirschmann Automation and Control GmbH  
Stuttgarter Str. 45-51  
72654 Neckartenzlingen  
Germany

# Contents

<b><i>Safety instructions</i></b>	<b>5</b>
<b><i>About this Guide</i></b>	<b>6</b>
References	6
Revision History	6
<b>1 EESX-Evaluation-Board Interfaces</b>	<b>7</b>
1.1 Overview	7
1.2 Power supply	8
1.3 Twisted Pair Ethernet Interface	9
1.4 Fiber optic Ethernet Interface	10
1.5 Mode-switch Settings for Ethernet Ports	10
1.6 Port count	11
1.7 LED Status Indication	11
1.8 Measuring Point Connectors	12
1.9 EESX Socket (CO201 and CO202)	13
1.10 JTAG Connection (CPLD)	13
1.11 Sub D9 Socket RS232	13
1.12 Push Buttons	14
<b>2 EESX Module Socket</b>	<b>15</b>
2.1 Mechanics	15
2.1.1 EESX-Module with Heat Spreader	17
2.1.2 Components to be cooled on EESX-Module	18
2.2 PIN Assignment at connector CO201	19
2.3 PIN Description for connector CO201	21
2.4 PIN Assignment at connector CO202	22
2.5 PIN Description for connector CO202	23
<b>3 Application Guide Line</b>	<b>25</b>
3.1 Ethernet interface for 10/100Base-TX connection	25
3.2 Ethernet interface for 1000Base-TX	26
3.3 Ethernet interface for 100Base-FX	26
3.3.1 Interface Connection (SFP Transceiver)	26
3.3.2 Interface connection (1*9 Transceiver)	27
3.4 Ethernet interface for 1000Base-FX	28
3.4.1 Interface Connection (SFP Transceiver)	28
3.4.2 Interface connection (1*9 Transceiver)	29
3.5 SPI Interface connection	30
3.5.1 SPI Protocol Timing	32
3.6 I2C Interface connection	33
3.7 Host Device connection over an Ethernet Interface	34
3.7.1 Capacitive Coupling – 100Base-FX	34

3.7.2	Magnetics Coupling – 10/100Base-TX	34
3.7.3	Capacitive Coupling – 1000Base-FX	35
3.7.4	Magnetics Coupling – 1000Base-TX	36
<b>3.8</b>	<b>Layout recommendations</b>	<b>36</b>
<b>3.9</b>	<b>Recommended Magnetic</b>	<b>37</b>
<b>4</b>	<b><i>Heat sink</i></b>	<b>38</b>
4.1	Permissible operating temperature	38
4.2	Estimation of heat sink's cooling performance	39
<b>5</b>	<b><i>Technical Data</i></b>	<b>40</b>
<b>6</b>	<b><i>Further Support</i></b>	<b>44</b>

# Safety instructions

This documentation contains instructions which must be observed to ensure your own personal safety and to avoid damage to devices and machinery.

## ■ Certified usage

The device may only be employed for the purposes described in the catalog and technical description, and only in conjunction with external devices and components recommended or approved by the manufacturer. The product can only be operated correctly and safely if it is transported, stored, installed and assembled properly and correctly. Furthermore, it must be operated and serviced carefully.

## ■ Qualification requirements for personnel

Qualified personnel as understood in this manual and the warning signs are persons who are familiar with the setup, assembly, startup, and operation of this product and are appropriately qualified for their job. This includes, for example, those persons who have been:

- ▶ trained or directed or authorized to switch on and off, to ground and to label power circuits and devices or systems in accordance with current safety engineering standards;
- ▶ trained or directed in the care and use of appropriate safety equipment in accordance with the current standards of safety engineering;
- ▶ trained in providing first aid.

## ■ National and international safety regulations

- Make sure that the electrical installation meets local or nationally applicable safety regulations.

## ■ Note on the CE marking

The EESX module is not intended for end users in accordance with item 2(1)b) of the EMC Directive 2004/108/EG. See also chapter 1.2 in "Guide for the EMC Directive 2004/108/EC (21st May 2007)". The manufacturer or distributor of the end device in which the EES was installed, is responsible for adhering to the applicable EU directives, as well as the CE marking.

The EMC tests were performed in combination with the Evaluation Board.

## ■ Maintenance

- When designing this device, Hirschmann was largely able to forego using wear parts. The parts subject to wear are dimensioned to last longer than the lifetime of the product when it is operated normally.
- Relays are subject to natural wear. This wear depends on the frequency of the switching operations. Check the resistance of the closed relay contacts and the switching function periodically according to the frequency of the switching operations.
- Hirschmann continually works on improving and developing their software. You should regularly check whether there is a new version of the software that provides you with additional benefits. You will find software information and downloads on the product pages of the Hirschmann website.

## ■ ESD guidelines

The media modules contain components highly sensitive to electrostatic fields. These components can be easily destroyed or have their lives shortened by an electrical field or by a discharge caused by touching the contacts. You can find more information about devices vulnerable to electrostatic fields in IEC/TR 61340-5-2 (2007-08)

## ■ Recycling note

After usage, this product must be disposed of properly as electronic waste, in accordance with the current disposal regulations of your county, state and country.

## ■ WARNING

Parts on EESX20/30 module or EESX-Evaluation-Board should not be touched in operation!

Due to possible hot spots of electrical components – especially the case of integrated circuits.

## About this Guide

This document provides technical specifications for the Embedded Ethernet Switch eXtended (EESX) Evaluation-Board. It also illustrates hardware integration guidelines for a Hirschmann Embedded Ethernet Switch eXtended (EESX) module. It describes the board level interfaces as well as the key operation parameters. Additionally, it provides the necessary information for a developer to validate their application design using the EESX-Evaluation-Board.

The information in this publication merely contain general descriptions or performance factors which, when applied in an actual situation, do not always correspond with the described form and may be amended by way of the further development of products. The desired performance factors shall only be deemed binding if these are expressly agreed on conclusion of the contract. Please note that some characteristics of the recommended accessory parts may differ from the appropriate product. This might limit the possible operating conditions for the entire system.

## References

On the EESX Development Kit CD you can find additional documents for the EESX-Evaluation-Board. It is recommended to use these documents when developing your application.

- ▶ EESX-Evaluation-Board schematics in PDF format
  - ▶ EESX-Evaluation-Board Gerber files
  - ▶ EESX-Evaluation-Board PCB layout files
- VHDL code of CPLD on EESX-Evaluation-Board

## Legend

The symbols used in this manual have the following meanings:

▶	Listing
□	Work step
■	Subheading

## Revision History

Version	Date	Page	Description
1.0	09/2014		Preliminary
1.1	02/2015		General revised
1.2	08/2015		Chapter "Recommended magnetics" added
1.3	11/2016	28	Schematic of Interface connection (1*9 Transceiver) modified
1.4	01/2017	26	Schematic of Interface connection 100Mbps (1*9 Transceiver) modified
1.5	04/2020	21 24,25,26,28 31 32	changed UE_Ok to input and updated description for VMag_P12 changed "not used" to "do not connect" added comment to Figure 3-8 changed R111=4.7K to R111=1K
1.6	03/2021	8, 14, 21, 33 20,23  1,2 44	UE_ok and accociated push button, do not connect I2C_Clk_x for low level 2× graphics for pin assignments of interface connectors CO201 & CO202 added Technical support address and Copyright text changed Chapter "Further support" changed

# 1 EESX-Evaluation-Board Interfaces

## 1.1 Overview

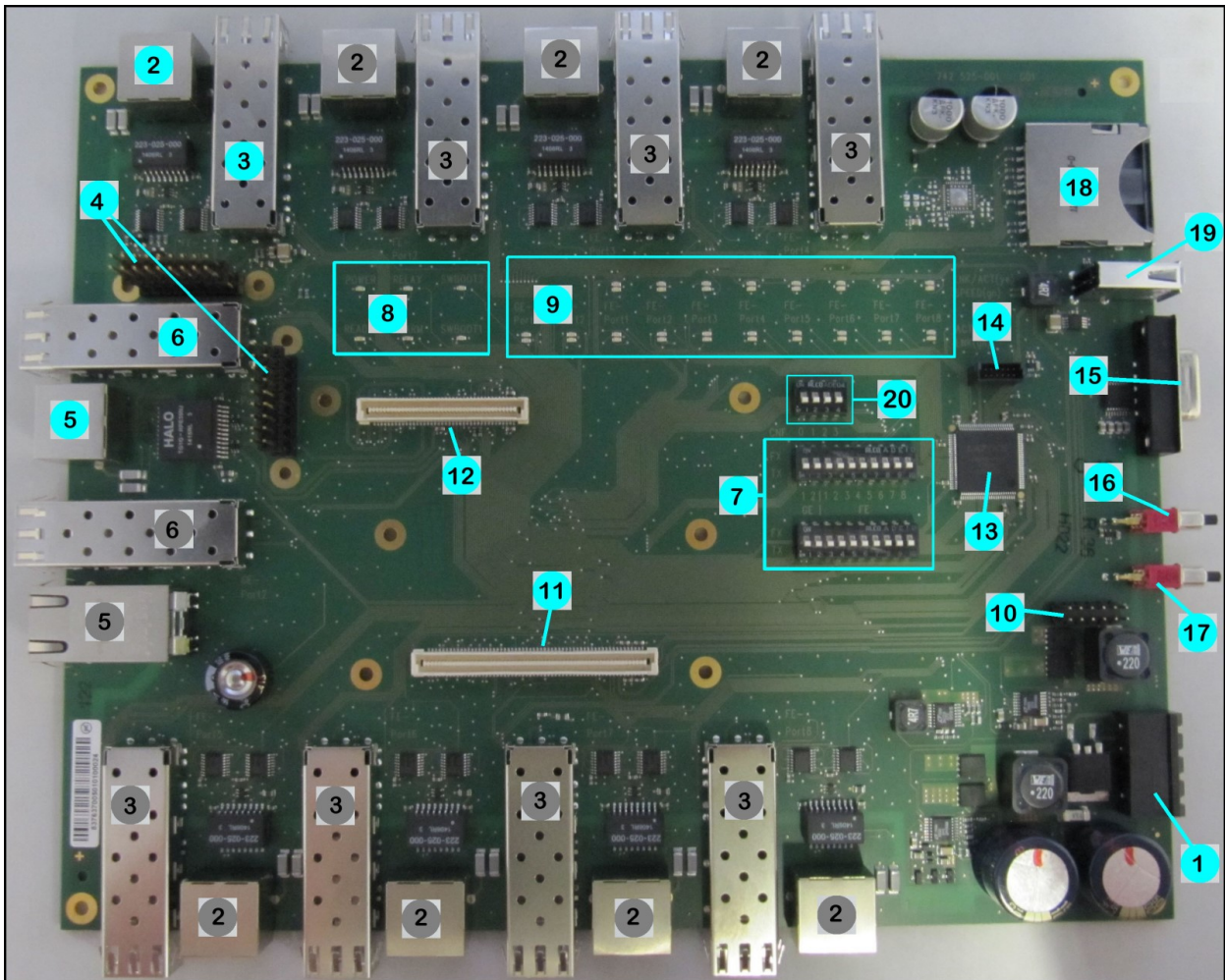

Figure 1-1: Components of the PCB-assembly

The hardware EESX-Evaluation-Board offers:

- (1) DC Jack for 24 VDC external power supply
- (2) 8 x Magnetics + RJ45 connector for 10/100Base-TX.
- (3) 8 x SFP cages for 100Base-FX transceivers.
- (4) 2 x DSC adapter for 100Base-FX transceivers at FE-Port 1 and GE-Port 1
- (5) 2 x Magnetics + RJ45 connector for 10/100/1000Base-TX.
- (6) 2 x SFP cages for 1000/100Base-FX transceivers.
- (7) Mode-switches to set hardware mode to Base-TX (Copper) or to Base-FX (optical fibre)
- (8) LEDs for module status
- (9) LEDs for status information of link and data activity per port as well for device status
- (10) 12-pin header with signals as measuring points (CO402)
- (11) 120-pin, dual-row vertical male EESX connectors (CO201)

- (12) 80-pin, dual-row vertical male EESX connectors (CO202)
- (13) CPLD for control signals
- (14) CPLD JTAG connector (CO401)
- (15) RS-232 connector (SubD-9) for serial communication
- (16) Push button: "Ue\_Ok" (SW401) – Power supply Reset
- (17) Push button: "PGOOD\_PLD" (SW402)
- (18) SD Card slot
- (19) USB connector
- (20) Configuration switch (currently without function)

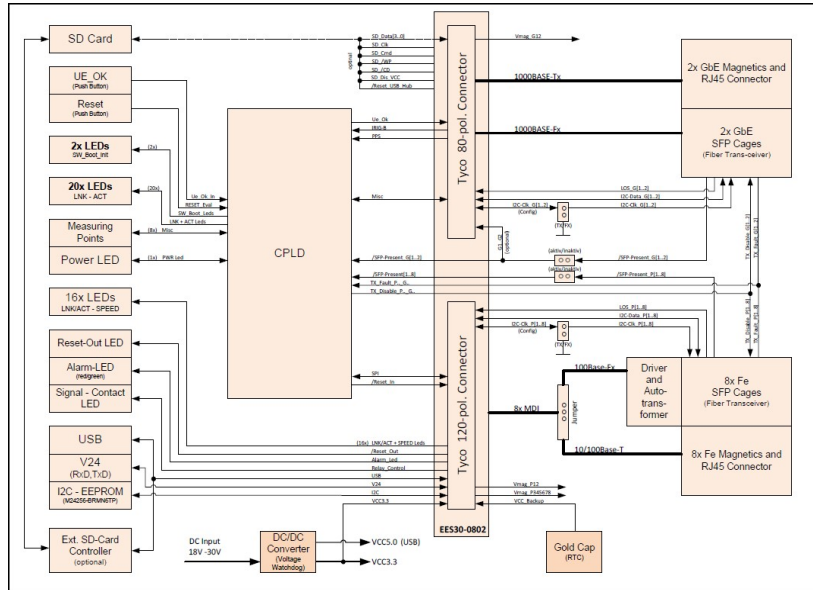

Figure 1-2: Block diagram EESX-Evaluation-Board

## 1.2 Power supply

Connect the DC jack on the EESX-Evaluation-Board to a 24 VDC power supply. Connect pins (1, 4) of the jack to +UE and the center pins (2, 3) of the jack to GND.

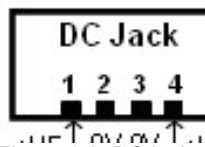

Figure 1-3: DC jack connection

The nominal voltage of the EESX-Evaluation-Board is 24V DC but also the EESX-Evaluation-Board can be supplied with +18 V up to +30 V at UE1 and/ or UE2.

Supply the EESX-Evaluation-Board only inside this voltage range!

The Capacitance of C305 and C307 summed in the schematic should be at least 1000 uF at 24V power supply to ensure faultless operation if voltage interruptions of 10 ms occur!



### 1.3 Twisted Pair Ethernet Interface

The 10/100 and 1000 Mbit/s Ethernet ports (IEEE 802.3 10/100 Base-TX) use RJ45 sockets, and support:

- ▶ Auto negotiation
- ▶ Auto polarity
- ▶ Auto crossing (if auto negotiation is activated)
- ▶ 1000 Mbit/s full-duplex mode, only Ports 1 and 2 of EESX30
- ▶ 100 Mbit/s half-duplex mode, 100 Mbit/s full-duplex mode
- ▶ 10 Mbit/s half-duplex mode, 10 Mbit/s full-duplex mode

Default configuration: auto negotiation enabled.

**Note:**

EESX20: Ports 1 to 8 support Fast Ethernet, e.g. 10/100 Base-T (TX) full or half duplex.

EESX30: Ports 1 and 2 support Gigabit Ethernet, e.g. 10/100/1000 Base-T (TX) full or half duplex.

Ports 3 to 10 support Fast Ethernet, e.g. 10/100 Base-T (TX) full or half duplex.

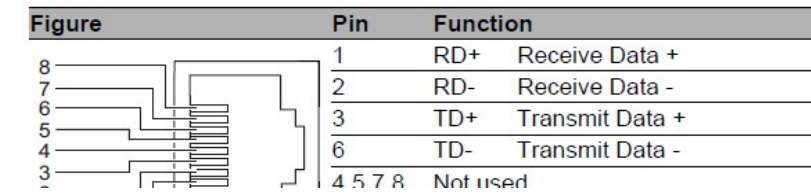

Figure 1-4: RJ45 Ethernet socket (100Mbit/s)

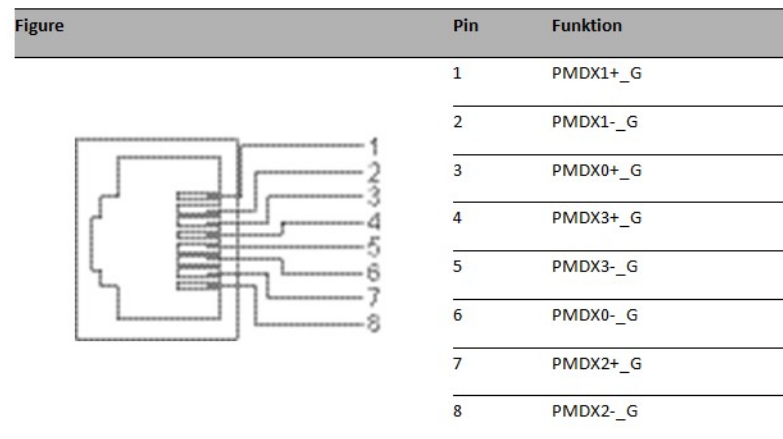

Figure 1-5: RJ45 Ethernet socket (1000 Mbit/s)

Connect only cable for Ethernet data transfer to these ports!

## 1.4 Fiber optic Ethernet Interface

The EESX-Evaluation-Board provides SFP cages for optical Fast Ethernet (100Base-FX) SFP transceivers for every Ethernet port. Even EESX30 module supports additionally 1000BASE-FX for GE-at Ports # 1 and 2.

An optical DSC (1\*9) transceiver is available at FE-Port 1 and can be implemented at customer's design for each FE-Port. (DSC transceiver at (Gigabit) GE-Ports are currently not supported by the software.)

Please contact the Hirschmann Service to order single DSC transceivers for your development. Find the contact data of the service in the last chapter of this manual.

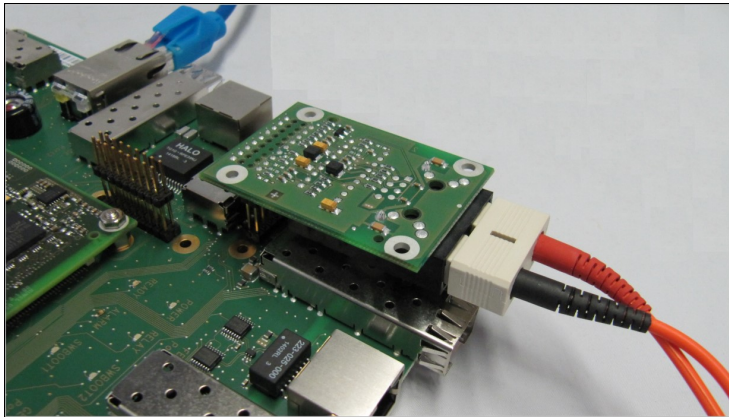

Figure 1-6: FE-Port 1 with DSC transceiver for 100Base-FX

## 1.5 Mode-switch Settings for Ethernet Ports

Each Fast Ethernet port (FE) can operate in either 10/100Base-TX (using RJ45 connectors) or 100Base-FX mode (using the SFP port) selected by the two Mode-switches (see Figure 1-7). The Gigabit Ethernet ports (GE) can operate in either 1000Base-TX or 100/1000Base-FX mode.

To change between TX and FX mode both switchover contacts of each port must be put to TX or FX position.

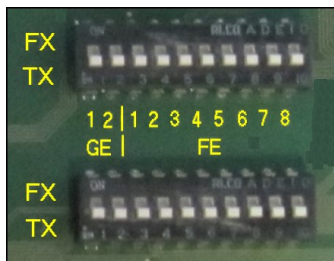

Figure 1-7: Enable Copper (TX) or optical (FX) communication interface

**Note:** See chapter 3.4 for more information about setting the ports to TX or FX mode.

**Note:** Port mode changes are activated after resetting the device.

## 1.6 Port count

Depending from the hardware type of EESX module the port count used in the software is different.

Module EESX20 has eight Fast Ethernet ports (FE) and EESX30 has additionally two Gigabit Ethernet ports (GE).

In Table 1-1 means *Physical Port* the port numbering on EESX-Evaluation-Board and *Logical Port* means the numbering by the software.

EESX-Evaluation-Board Physical Port	EESX20 Module Logical Port	EESX30 Module Logical Port
GE-Port 1	Not available	Port 1
GE-Port 2	Not available	Port 2
FE-Port 1	Port 1	Port 3
FE-Port 2	Port 2	Port 4
FE-Port 3	Port 3	Port 5
FE-Port 4	Port 4	Port 6
FE-Port 5	Port 5	Port 7
FE-Port 6	Port 6	Port 8
FE-Port 7	Port 7	Port 9
FE-Port 8	Port 8	Port 10

Table 1-1: Port assignment from Evalboard to EESX20/30

## 1.7 LED Status Indication

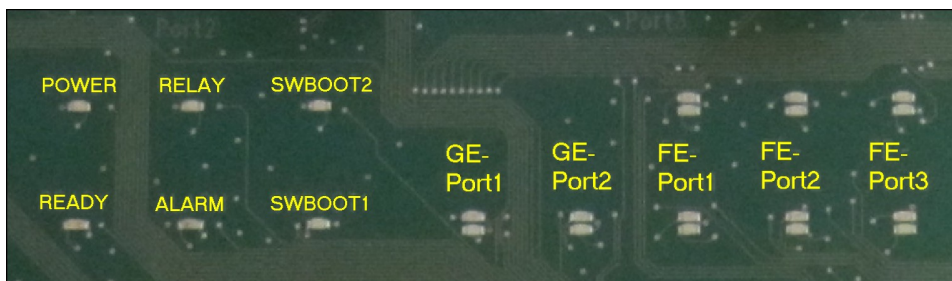

Figure 1-8: Status LEDs on EESX-Evaluation-Board

	Status	Description
POWER	Off	EESX-Evaluation-Board is unpowered.
	Green	EESX-Evaluation-Board is powered.
RELAY	Off	Signal "Relay_Control" is low, System is not ready.
	Green	Signal "Relay_Control" is high, System is ready.
SWBOOT2	Off	Software is not loaded.
	Green	Software is loaded.
READY	Off	Software is not loaded, System is not ready.
	Light green	Software is loaded, System is ready.
ALARM	Off	System (software) is running.
	RED	System indicates abnormal operation status.
SWBOOT1	Off	Software is not loading.
	Green	Software is loading.
GE-Port[1..2]	Off	No link (no physical connection).
	Green	Link is up (physical connection available).
	Off	No data traffic.
	Yellow blinking	Data traffic.
FE-Port[1..8]	Off	No link.
	Green	Link is up.
	Off	No data traffic.
	Yellow blinking	Data traffic.

Table 1-2: LED status indication

## 1.8 Measuring Point Connectors

The 12-pin, dual-row connector on the EESX-Evaluation-Board give access to several EESX spare signals on connector CO402 which are reserved for future use. (See (10) in Figure 1-1.)

The signals are LVTTTL level.

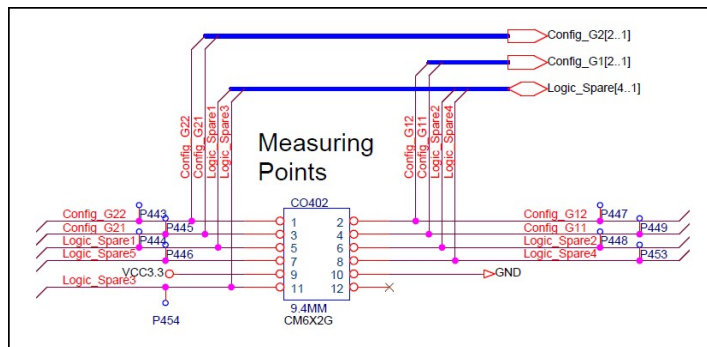

Figure 1-9: EESX-Evaluation-Board schematic (part Measuring points)

## 1.9 EESX Socket (CO201 and CO202)

The 120-pin dual-row socket CO201 and 80-pin dual-row socket CO202 on EESX-Evaluation-Board are used to mount the EESX20/30 module. Both sockets are the electrical interface between the EESX module and its Evaluation-Board. The interface connects the power supply, the Ethernet, logical and other signals.

For more details see chapter 2.

## 1.10 JTAG Connection (CPLD)

The CPLD IC401 (Lattice IC LCMXO2-640-4, see (13) in Figure 1-1) on EESX-Evaluation-Board can be programmed via connector CO401.

Pin #	Signal	Pin #	Signal
1	VCC3.3_PLD	2	RTCK
3	TCK	4	TMS
5	n.c.	6	TDI
7	TDO	8	GND
9	n.c.	10	n.c.
11	n.c.	12	n.c.

Table 1-3: Pin assignment CO401

## 1.11 Sub D9 Socket RS232

A serial data RS232 (V24\_TxD/RxD) connection is available on the EESX-Evaluation-Board to provide access to the EESX module. This enables you to set up a connection to the Command Line Interface (CLI) and system monitor. For more information on the CLI functionality, refer to the Command Line Interface (EES) Reference Manual.

The serial interface uses RS232 (V.24) without hardware handshake. A SubD9 connector is mounted on the EESX-Evaluation-Board for this purpose.

RS232 socket pin description (SubD9 female):

- ▶ Pin 2 -> RxD (Data from the EESX-Evaluation-Board to the host)
- ▶ Pin 3 -> TxD (Data from host to Evaluation-Board)
- ▶ Pin 5 -> GND

Configure your terminal emulator (for example, Hyperterm, TeraTerm, PUTTY) with the following settings to issue CLI commands to the EESX module through the RS232 connection:

Terminal Settings	
Speed	9600 Baud
Data	8 bit
Stop bit	1 bit
Hand shake	off
Parity	none

Table 1-4: Parameters

## 1.12 Push Buttons

The following push buttons are available on the EESX-Evaluation-Board:

- ▶ Push button SW401 to signal “Ue\_Ok”: Resets the EESX module if button pushed. See (16) in Figure 1-1. The Reset is not done as a result of the signal Ue\_Ok change. It is due to a power supply reset at the EESX-Evaluation-Board.
- ▶ Push button SW402 to signal “PGOOD\_PLD”: See (17) in Figure 1-1. Tracks the signal “PGOOD\_PLD” to ground (GND) potential if button pushed. This button is for test purposes.

## 2 EESX Module Socket

### 2.1 Mechanics

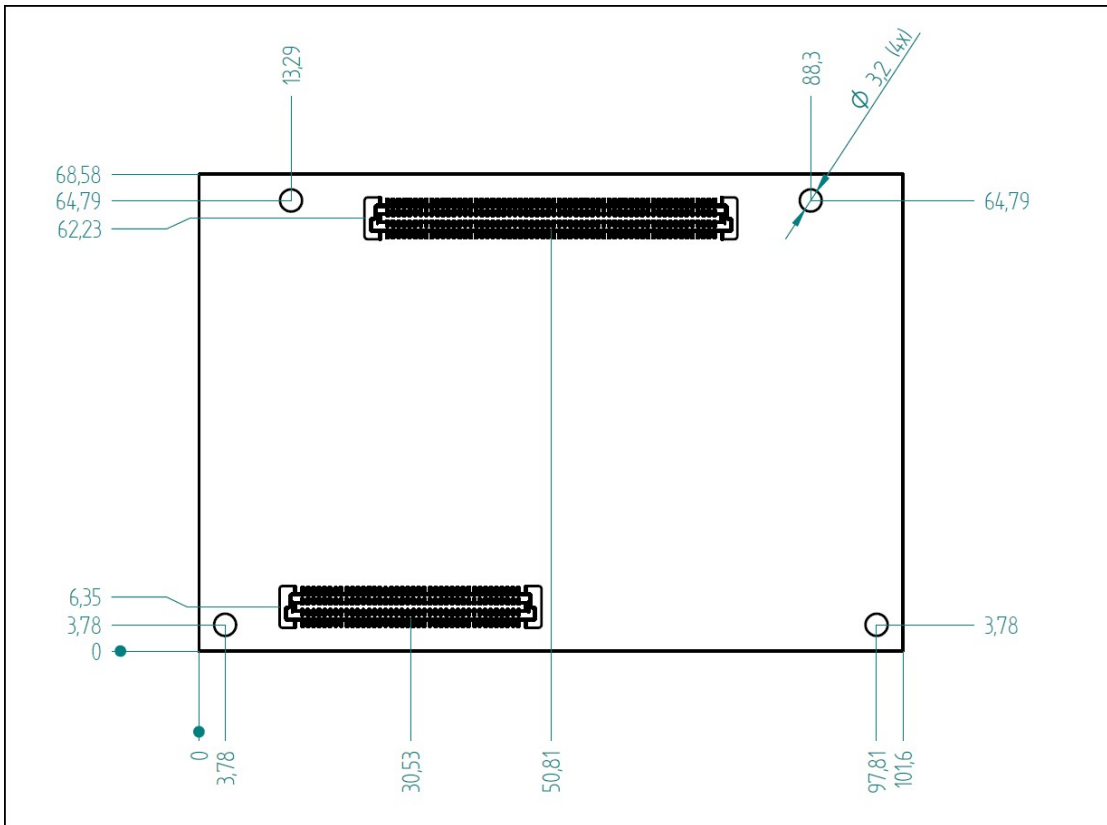

Figure 2-1: EESX module with interconnectors; Bottom view

The opposite interconnectors on the EESX-Evaluation-Board are manufactured by TE Connectivity ([www.te.com](http://www.te.com)).

Part number:

- Connector male 120 pins: 5084614-5 (Package Tube) or 5-5177986-5 (Package Tape and Reel).
- Connector male 80 pins: 5084614-3 (Package Tube) or 5-5177986-3 (Package Tape and Reel).

A stacking height of 5 mm is obtained as illustrated in Figure 2-2; at some positions less than 3 mm due to high components.

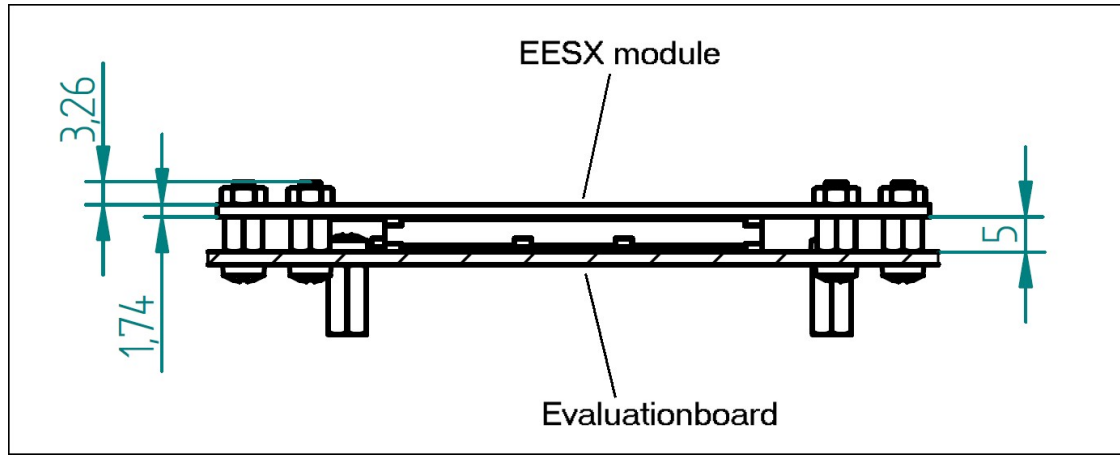

Figure 2-2: EESX module mounted on EESX-Evaluation-Board with screws and nuts; sectional drawing

**Note:**

It is recommended for customer's applications to let the space idle beneath the module board for better heat dissipation of the module.



### 2.1.1 EESX-Module with Heat Spreader

The figure below shows the position of the drill-holes for the screws of the cooling block and the total height of the module. For details about the Heat dissipation parameters see chapter "Heat sink":

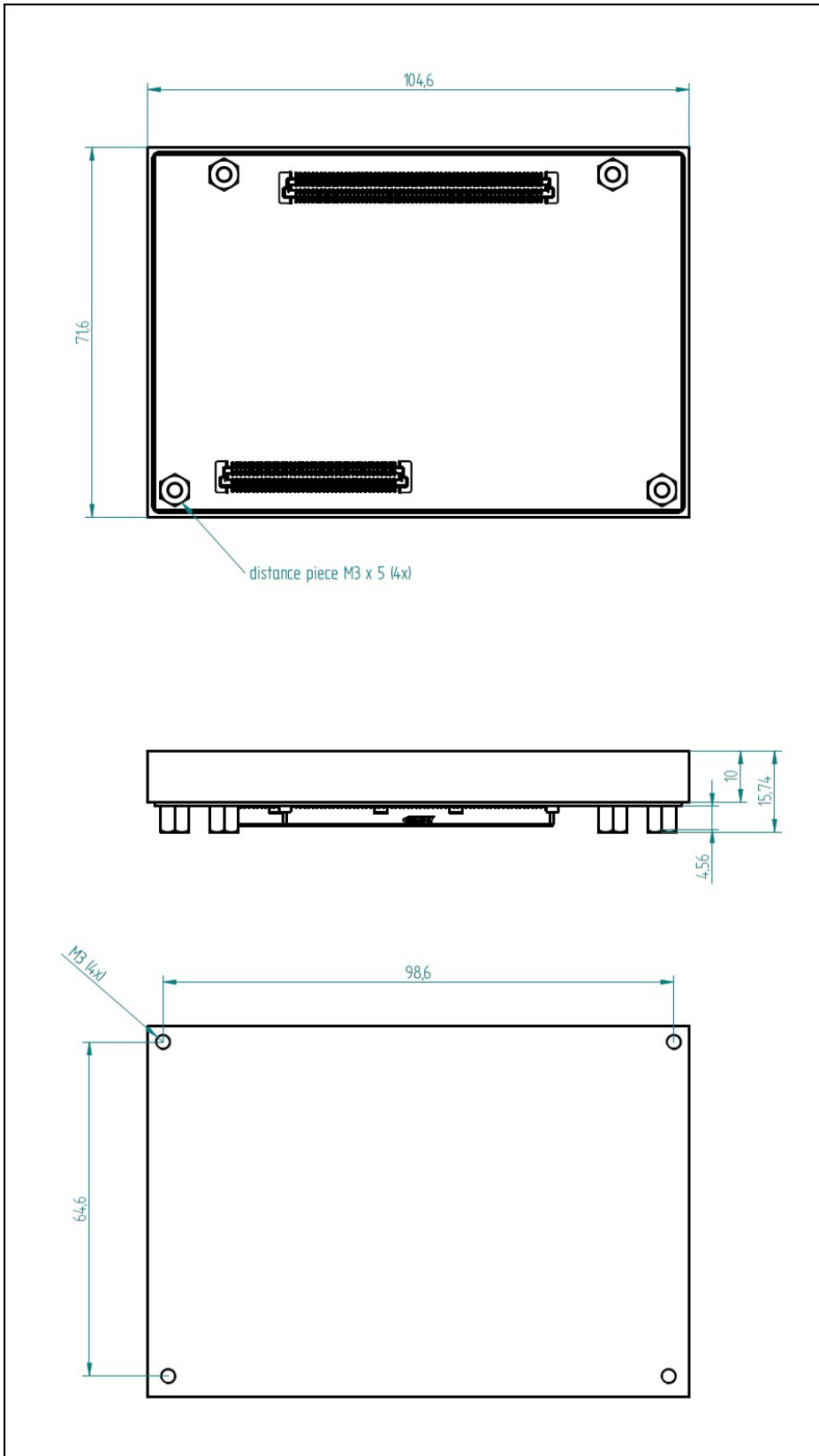

Figure 2-3: EESX module with mounted cooling plate; Bottom-, side-, and top-view

### 2.1.2 Components to be cooled on EESX-Module

The following ICs should be cooled if the permissible case temperature will be exceeded. (See Chapter *Technical Data* for case temperature.)

Component	x-direction / mm	y-direction / mm
IC401	28	28
IC901	17,5	17,5
IC902	14	8
IC1002	6	8
IC602 (EESX30 only)	12,2	12,2
IC202	6,82	4,5
IC203	7	4,5
IC205	4,5	7

Table 2-1: Dimensions of ICs to be cooled on EESX-Module (related to Figure 2-4)

#### Component positions on ESSX board for a heat sink

In the picture below are the positions of the components on EESX board which should be connected to a heat sink for cooling.

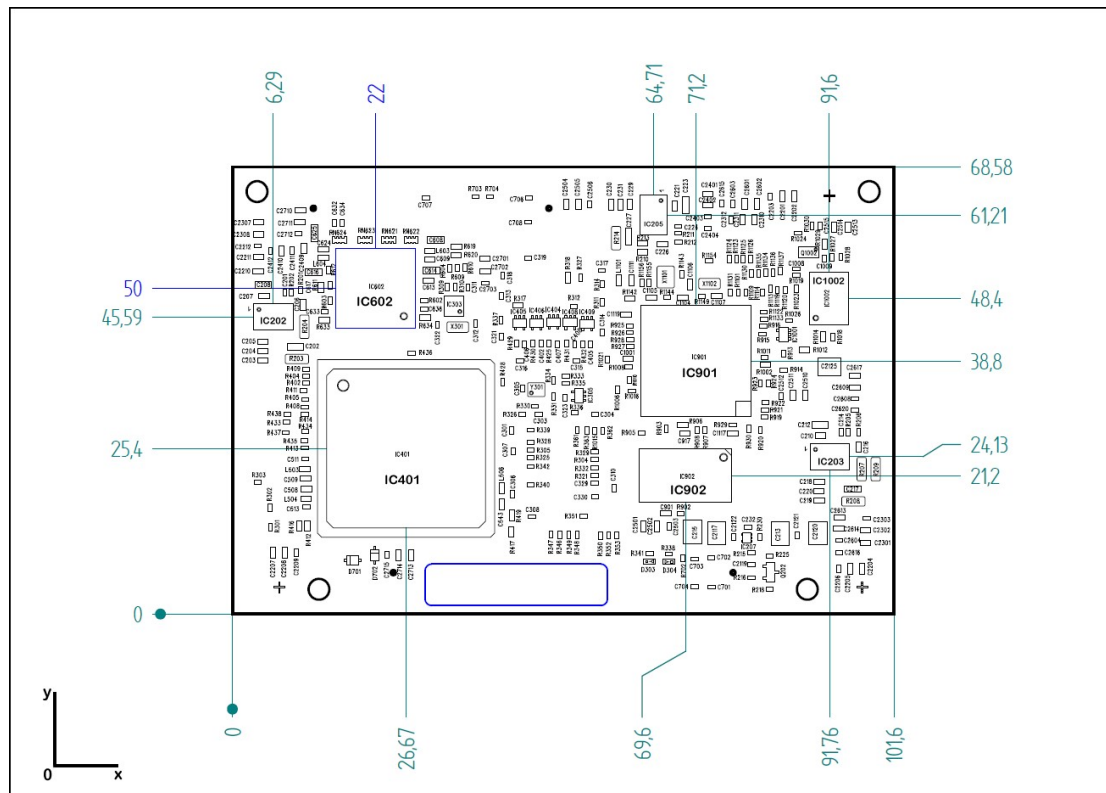

Figure 2-4: Positions of ICs to be cooled on EESX-Module TOP VIEW

#### Component heights on ESSX board for a heat sink

Component	Height (min.)	Height (nominal)	Height (max.)
IC401	2.20 mm	2.33 mm	2.52 mm
IC901	Not available	Not available	1.60 mm
IC902	Not available	Not available	1.20 mm
IC1002	0.70 mm	0.75 mm	0.80 mm
IC202, IC203, IC205	1.05 mm	1.1 mm	1.15 mm
IC602 (EESX30 only)	Not available	Not available	1,78 mm

Table 2-1: Component heights of ICs to be cooled on EESX-Module

According to supplier's data sheets. Recommended additional tolerance: 0.4 mm.

## 2.2 PIN Assignment at connector CO201

Table 2-1 and Table 2-2 describe the pin out and signals names of the interconnectors CO201 mounted on the EESX-Evaluation-Board and its complementary one on the module.

CO201			
Pin	Name	Pin	Name
1	VCC3.3_EES	2	VCC3.3_EES
3	VCC3.3_EES	4	VCC3.3_EES
5	VCC3.3_EES	6	Ue_Ok
7	GND	8	GND
9	GND	10	GND
11	VMag_P38	12	VMag_P12
13	USB_D+	14	USB_/OC
15	USB_D-	16	USB_Pwr_on
17	V24_TxD	18	I2C_Clk_Aux
19	V24_RxD	20	I2C_Da_Aux
21	/System_ready	22	/LED_Alarm
23	SPI_MISO_Aux	24	Relay_Control
25	SPI_MOSI_Aux	26	/Reset_in
27	LOS_P8	28	LOS_P7
29	LOS_P6	30	LOS_P5
31	LOS_P4	32	LOS_P3
33	LOS_P2	34	LOS_P1
35	/LED_Lnk_Act_P8	36	/LED_Lnk_Act_P7
37	/LED_Lnk_Act_P6	38	/LED_Lnk_Act_P5
39	/LED_Lnk_Act_P4	40	/LED_Lnk_Act_P3
41	/LED_Lnk_Act_P2	42	/LED_Lnk_Act_P1
43	/LED_Speed_P8	44	/LED_Speed_P7
45	/LED_Speed_P6	46	/LED_Speed_P5
47	/LED_Speed_P4	48	/LED_Speed_P3
49	/LED_Speed_P2	50	/LED_Speed_P1
51	I2C_Clk_P8	52	I2C_Clk_P8
53	I2C_Clk_P6	54	I2C_Clk_P8
55	I2C_Clk_P4	56	I2C_Clk_P8
57	I2C_Clk_P2	58	I2C_Clk_P8
59	SPI_Clk_Aux	60	SPI_/SS_Aux
61	GND	62	GND
63	I2C_Da_P8	64	I2C_Da_P7
65	I2C_Da_P6	66	I2C_Da_P5
67	GND	68	GND
69	I2C_Da_P4	70	I2C_Da_P3
71	I2C_Da_P2	72	I2C_Da_P1
73	GND	74	GND
75	TD+P8	76	RD+P8
77	TD-P8	78	RD-P8
79	GND	80	GND
81	TD-P7	82	RD-P7
83	TD+P7	84	RD+P7

CO201			
Pin	Name	Pin	Name
85	GND	86	GND
87	TD+P6	88	RD+P6
89	TD-P6	90	RD-P6
91	GND	92	GND
93	TD-P5	94	RD-P5
95	TD+P5	96	RD+P5
97	GND	98	GND
99	TD+P4	100	RD+P4
101	TD-P4	102	RD-P4
103	GND	104	GND
105	TD-P3	106	RD-P3
107	TD+P3	108	RD+P3
109	GND	110	GND
111	TD+P2	112	RD+P2
113	TD-P2	114 <td RD-P2	
115	GND	116	GND
117	TD-P1	118	RD-P1
119	TD+P1	120	RD+P1

Table 2-2: Pin assignment of interface connector CO201

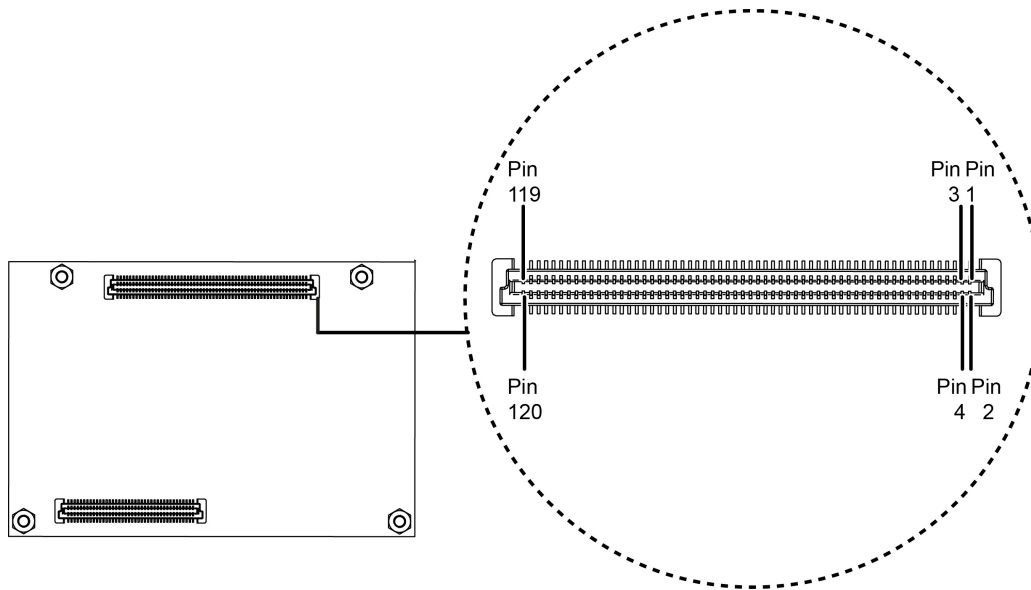

Figure 1 Pin assignment of interface connector CO201

## 2.3 PIN Description for connector CO201

Signal Name	Type I/O (EESX)	Type (EESX)	Description
VCC3.3 EES	Power	3.3 Volts +-5%	Power supply of the module for 3.3 Volts.
Ue_Ok	Input	LVTTTL	Not used
GND	Ground	0 Volts	Ground potential for signals and power supply.
VMag_P38	Power	2.5 Volts	Power supply for FE-Ports' magnetics.
VMag_P12	Power	2.5 Volts	Power supply for FE-Ports' magnetics.
USB_D+/-	<i>Bidirectional</i>	5 Volts diff.	Differential USB data line.
USB_/OC	Input	LVTTTL	Indicates overcurrent or thermal shutdown conditions. Active low.
USB_Pwr_on	Power	LVTTTL	USB Power source output for 5 Volts. Enable = high
V24_TxD	Output	LVTTTL	Transmit line of RS232 interface.
V24_RxD	Input	LVTTTL	Receive line of RS232 interface.
I2C_Clk_Aux	<i>Bidirectional</i>	LVTTTL	Clock line of I2C-Auxiliary-bus.
I2C_Da_Aux	<i>Bidirectional</i>	LVTTTL	Data line of I2C-Auxiliary-bus.
/System_ready	Output	LVTTTL	Control signal of LED "System ready". (low active)
/LED_Alarm	Output	LVTTTL	Control signal of LED "Alarm". (low active)
SPI_MISO_Aux	Input	LVTTTL	MISO line of SPI-bus to the CPLD chip.
SPI_MOSI_Aux	Output	LVTTTL	MOSI line of SPI-bus to the CPLD chip.
Relay_Control	Output	LVTTTL	Signal for Relay control
/Reset_in	Input	LVTTTL	Module reset. (low active)
LOS_P[1..8]	<i>Logical signal</i>	LVTTTL	Loss of signal for port 1 to 8. (for optical transceivers)
/LED_Lnk_Act_P[1..8]	Output	LVTTTL	LED signals port 1 to 8
/LED_Speed_P[1..8]	Output	LVTTTL	LED signals port 1 to 8
I2C_Clk_P[1..8]	<i>Bidirectional</i>	LVTTTL	Clock line of I2C-Port[1..8]-bus. (for optical transceivers)
SPI_Clk_Aux	Output	LVTTTL	Clock line of SPI-bus to the CPLD chip.
SPI_/SS_Aux	Output	LVTTTL	Slave select line of SPI-bus to the CPLD chip.
I2C_Da_P[1..8]	<i>Bidirectional</i>	LVTTTL	Data line of I2C-Port[1..8]-bus. (for optical transceiver)
TD+/-P[1..8]	<i>Output analog</i>	100BaseTX: +-1V diff. 10BaseTX: +-2,5V diff. 100BaseFX	Differential transmit lines for FE-Port [1..8]
RD+P[1..8]	<i>Input analog</i>	100BaseTX: +-1V diff. 10BaseTX: +-2,5V diff. 100BaseFX	Differential receive lines for FE-Port [1..8]

Table 2-3: Pin Descriptions (View from module side for I/O type)

## 2.4 PIN Assignment at connector CO202

Table 2-1 and Table 2-2 describe the pin out and signal names of the interconnectors CO202 mounted on the EESX-Evaluation-Board and its complementary ones on the module.

CO202			
Pin	Name	Pin	Name
1	GND	2	GND
3	VMag_G12	4	VMag_G12
5	VMag_G12	6	VMag_G12
7	I2C_Clk_G2	8	SD_Dat3
9	I2C_Clk_G1	10	SD_Clk
11	GND	12	GND
13	I2C_Da_G2	14	SD_Cmd
15	I2C_Da_G1	16	SD_Dat1
17	Logic_Spare3	18	SD_Dat2
19	/SFP_Present_EES_G2	20	SD_Dat0
21	/SFP_Present_EES_G1	22	SD_WP
23	GND	24	GND
25	LOS_G2	26	SD_/CD
27	LOS_G1	28	Logic_Spare4
29	GND	30	GND
31	Logic_Spare2	32	Logic_Spare1
33	Config_G11	34	Config_G21
35	Config_G12	36	Config_G22
37	GND	38	GND
39	SD_Dis_VCC	40	/Reset_USB_Hub
41	VCC_Backup	42	VCC_Backup
43	GND	44	GND
45	PMDX1+G1	46	PMDX0+G1
47	PMDX1-G1	48	PMDX0-G1
49	GND	50	GND
51	PMDX3+G1	52	PMDX2+G1
53	PMDX3-G1	54	PMDX2-G1
55	GND	56	GND
57	PMDX3+G2	58	PMDX2+G2
59	PMDX3+G2	60	PMDX2-G2
61	GND	62	GND
63	PMDX1+G2	64	PMDX0+G2
65	PMDX1-G2	66	PMDX0-G2
67	GND	68	GND
69	SGIN-G1	70	SGOUT-G1
71	SGIN+G1	72	SGOUT+G1
73	GND	74	GND
75	SGIN-G2	76	SGOUT-G2
77	SGIN+G2	78	SGOUT+G2
79	GND	80	GND

Table 2-4: Pin assignment of the interface connectors CO202

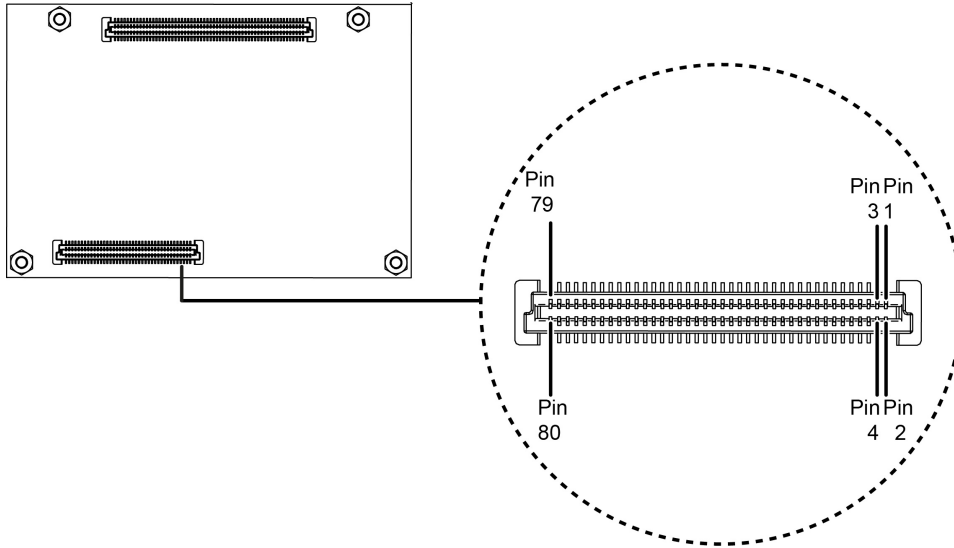

Figure 2 Pin assignment of the interface connectors CO202

## 2.5 PIN Description for connector CO202

Signal Name	Type I/O (EESX)	Type (EESX)	Description
GND	Ground	0 Volts	Ground potential for signals and power supply.
VMag_G12	Power	1.8 Volts	Power supply for Gigabit-Ports' magnetics.
I2C_Clk_G[1..2]	<i>Bidirectional</i>	LVTTTL	Clock lines of I2C for Gigabit-Ports 1 and 2. (for SFP-transceiver)
I2C_Da_G[1..2]	<i>Bidirectional</i>	LVTTTL	Data lines of I2C for Gigabit-Ports 1 and 2. (for SFP-transceiver)
SD_Dat[0..3]	<i>Bidirectional</i>	LVTTTL	Data lines 0..3 of the SD Card interface.
SD_Clk	<i>Output</i>	LVTTTL	Clock line of the SD Card interface.
SD_Cmd	<i>Output</i>	LVTTTL	Command line of the SD Card interface.
SD_WP	<i>Output</i>	LVTTTL	Write protect signal of the SD Card interface. (low active)
SD_CD	<i>Output</i>	LVTTTL	
SD_Dis_VCC	<i>Output</i>	LVTTTL	Disable of SD-Card power supply on Evalboard. High = disable / Low = enable
Logic_Spare[1..4]	<i>[Bidirectional]</i>	LVTTTL	Spare signals for logic on the Evaluation-Board.
/SFP_Present_EES_G[1..2]	<i>Logical signal</i>	LVTTTL	Signal "SFP present" at Gigabit-Ports 1 and 2. (low active), (for optical transceivers)
LOS_G[1..2]	<i>Logical signal</i>	LVTTTL	Signal "Loss Of Signal" at Gigabit-Ports 1 and 2. (high active), (for optical transceivers)
Config_G[11,12,21,22]	<i>Logical signal</i>	LVTTTL	Selection of a certain System configuration. Currently without function.
/Reset_USB_Hub	<i>Input</i>	LVTTTL	Reset of USB Hub. (low active)
VCC_Backup	Power		Backup of VCC for Real time clock on EESX module, Backup-capacitor on Evaluation-Board.

<b>Signal Name</b>	<b>Type I/O (EESX)</b>	<b>Type (EESX)</b>	<b>Description</b>
PMDX0+/-G[1..2]	<i>Bidirectional analog</i>	100/1000BaseTX: +-1V diff. 10BaseTX: +-2,5V diff.	1 <sup>st</sup> differential line pair for Gigabit-TX-Port [1..2]
PMDX1+/-G[1..2]	<i>Bidirectional analog</i>	100/1000BaseTX: +-1V diff. 10BaseTX: +-2,5V diff.	2 <sup>nd</sup> differential line pair for Gigabit-TX-Port [1..2]
PMDX2+/-G[1..2]	<i>Bidirectional analog</i>	100/1000BaseTX: +-1V diff. 10BaseTX: +-2,5V diff.	3 <sup>rd</sup> differential line pair for Gigabit-TX-Port [1..2]
PMDX3+/-G[1..2]	<i>Bidirectional analog</i>	100/1000BaseTX: +-1V diff. 10BaseTX: +-2,5V diff.	4 <sup>th</sup> differential line pair for Gigabit-TXPort [1..2]
SGIN+/-G[1..2]	<i>Input analog</i>	100BaseFX 1000BaseFX	Differential line pair for Gigabit-FX-Port [1..2] for data going to the module.
SGOUT+/-G[1..2]	<i>Input analog</i>	100BaseFX 1000BaseFX	Differential line pair for Gigabit-FX-Port [1..2] for data coming from the module.

Table 2-5: Pin Descriptions (View from module side for I/O type)



### 3 Application Guide Line

This chapter provides recommendations for implementation of the Ethernet and SPI interfaces.

#### 3.1 Ethernet interface for 10/100Base-TX connection

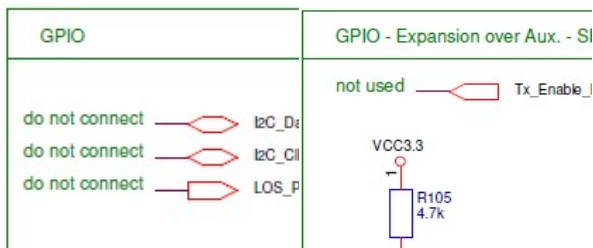
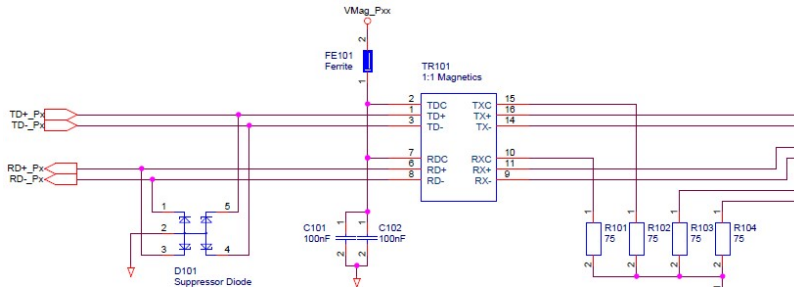

Figure 3-1: 10/100Base-TX interface recommendation

Signal Description: VMag_Pxx		Signal Description:	
	EESX-0802	GND	Signal - C
	EESX-0800		
Port-1 - Port-2	VMag_P12		

Table 3-1: 10/100Base-TX center tap voltage

For operational reasons the ports require different supply voltages for the center taps of the magnetic poles. See table 3-1 for details.

## 3.2 Ethernet interface for 1000Base-TX

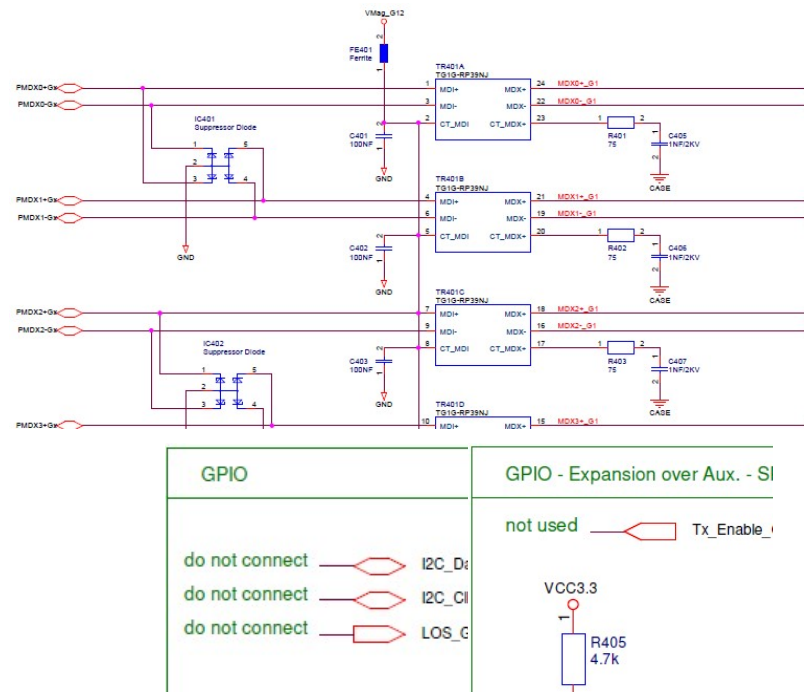

Figure 3-2: 1000Base-TX interface recommendation

## 3.3 Ethernet interface for 100Base-FX

### 3.3.1 Interface Connection (SFP Transceiver)

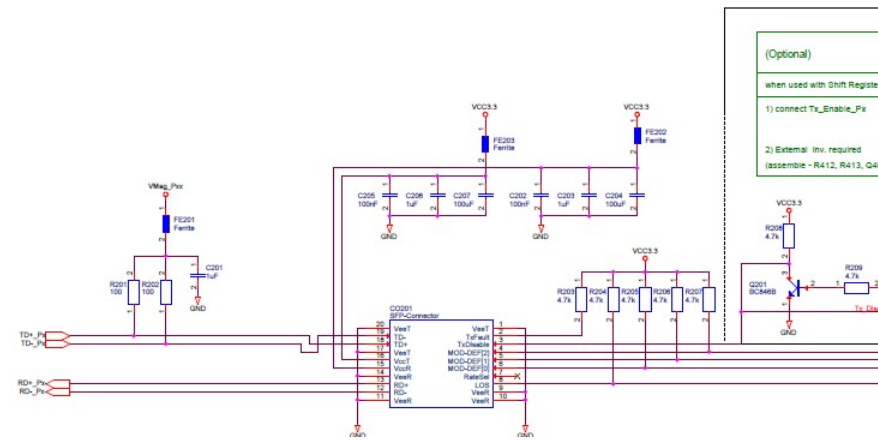

Figure 3-3: 100Base-FX (SFP) interface recommendation

Signal Description: VMag_P1x		Signal Description:	
	EESX-0802	GND	Signal - G
	EESX-0800		
Port-1 - Port-2	VMag_P12		

Table 3-2: 100Base-FX (SFP) schematic information

### 3.3.2 Interface connection (1\*9 Transceiver)

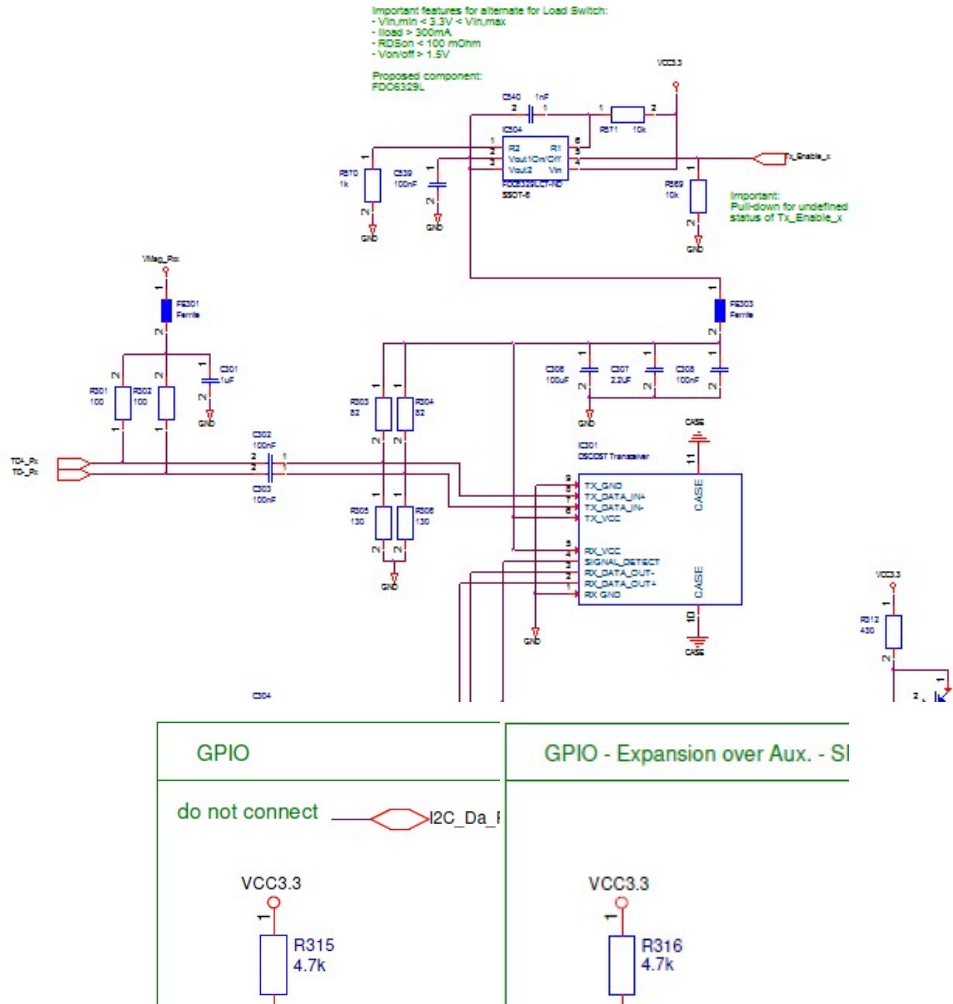

Figure 3-4: 100Base-FX (1\*9 transceiver) interface recommendation

Signal Description: VMag_Pxx		Signal Description:	
	EESX-0802	GND	Signal - G
	EESX-0800		
Port-1 - Port-2	VMag_P12		

Table 3-3: 100Base-FX (1\*9 transceiver) schematic information

### 3.4 Ethernet interface for 1000Base-FX

#### 3.4.1 Interface Connection (SFP Transceiver)

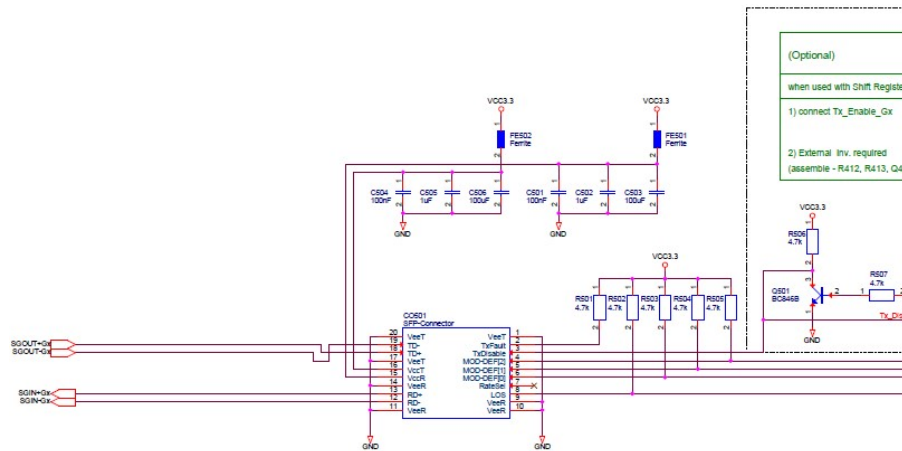

Figure 3-5: 1000Base-FX (SFP) interface recommendation

### 3.4.2 Interface connection (1\*9 Transceiver)

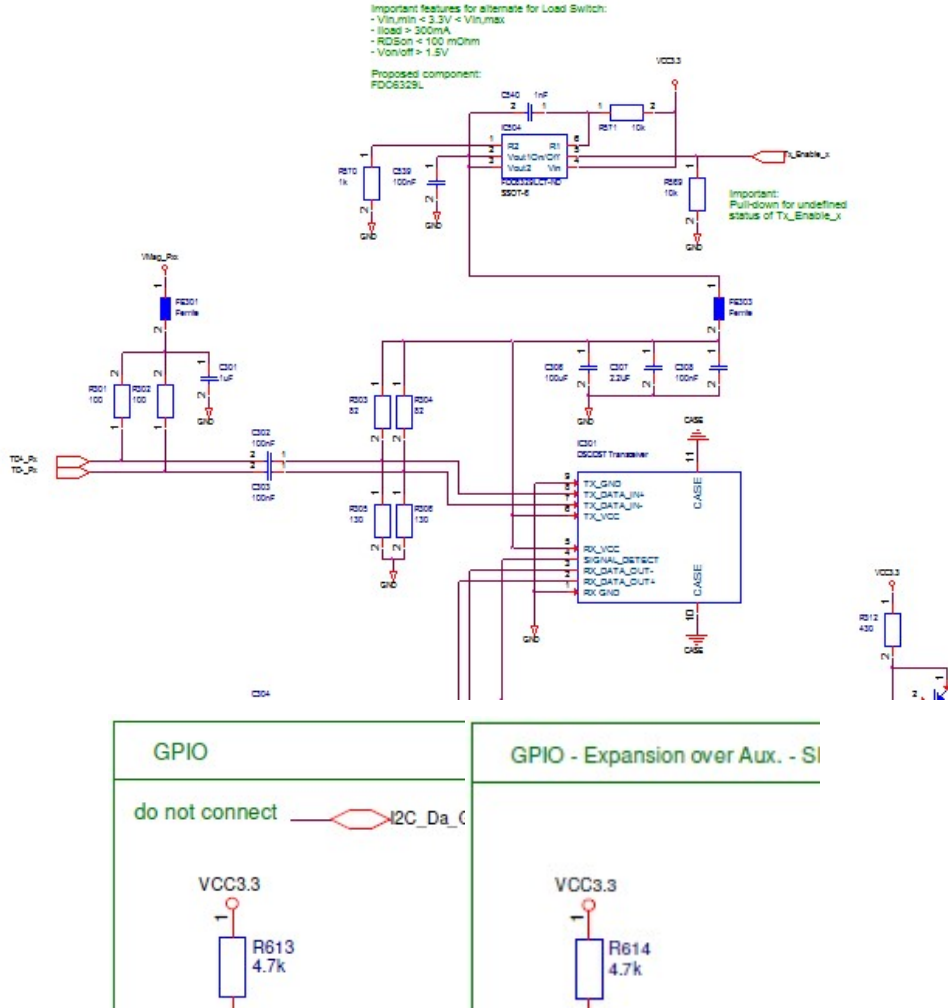

Figure 3-6: 1000Base-FX (1\*9 transceiver) interface recommendation

The feature 1\*9 Transceiver is currently not supported for the Gigabit ports 1 and 2. Use the Fast Ethernet ports instead.

### 3.5 SPI Interface connection

The EESX module provides a SPI interface (acts as SPI master) for status indication.

The EESX-Evaluation-Board communicates with the on-board CPLD via a SPI interface. The CPLD serializes and de-serializes the SPI data stream and provides the signals to I/O pins.

Pin	Direction *	Description
SPI_/SS	Serial Control Output	SPI <b>slave select</b> (also called chip select) control signal, storage Register
SPI_Clk	Serial Data clock	The clock signal produced from the master device to synchronize the data transfer.
SPI_MOSI	Serial Data Output	SPI data, <b>master out /slave in</b>
SPI_MISO	Serial Data Input	SPI data, <b>master in /slave out</b>

\* With respect to the EESX module.

*Table 3-4: SPI connector pin assignment*

It is recommended to use a CPLD chip for communication between EESX module and its outer periphery. The logic file of the CPLD chip on the EESX-Evaluation-Board is available on delivered CD/DVD.

The SPI-pins out definitions are described in Table 3-4. In the target application, the CPLD can be replaced alternatively with standard logic shift registers, for example the ICs 74HC595 or 74HC165 (see figure 3-4) which convert an in-coming 8 bit parallel data stream to an out-going serial data stream.

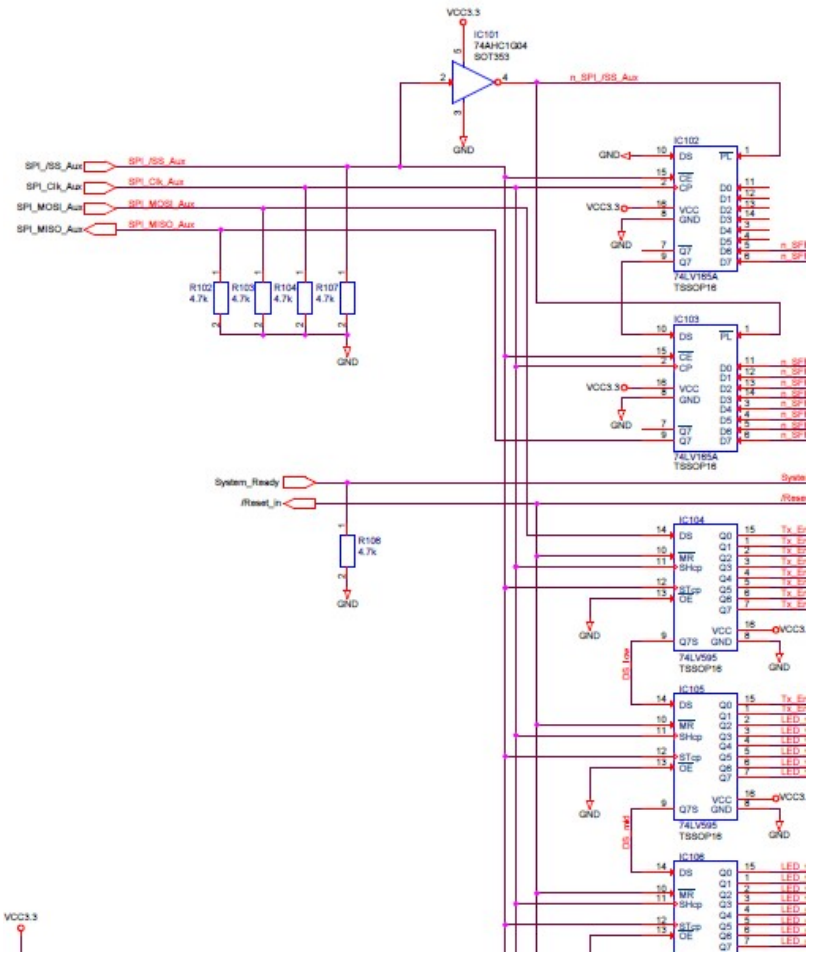

Figure 3-7: SPI implementation example as alternative for the CPLD chip

### 3.5.1 SPI Protocol Timing

Figure 3-5 illustrates every timing parameter in the SPI Protocol. These timing parameters are a result of the EESX internal operation and both constrain host behavior and characterize EESX operation. Note that Figure 3-5 is not drawn to scale, but is instead drawn only to illustrate where the parameters are measured. The EESX is the master and sends data on SPI\_MOSI and receives data on SPI\_MISO.

Attention: This is just a general drawing. The content of the SPI\_MOSI and SPI\_MISO bits must be taken from Table 3-6 and 3-7.

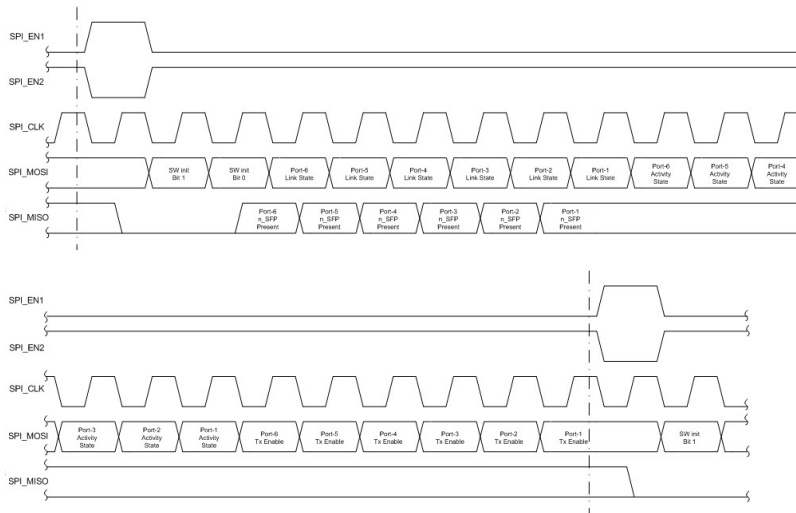

Figure 3-8: SPI Timing Diagram

Reading signals from the EESX module is similar to writing to it. The *SPI\_SS\_Aux* read/write command is sent first, followed by send and receive information in 32 bit patterns. The EESX module transmits link and data activity status information for every port. It transmits general status information to the host system on *SPI\_MOSI\_Aux* and also reads status information from the host system on *SPI\_MISO\_Aux*, providing of SFP transceivers is installed.

Bit	Signal name	Description
31... 30	<i>SW_Init_Phase[1..0]</i>	Software initializing during boot phase.
29... 22	<i>LED_gr_P[8..1]</i>	Link status for FE-Ports 8..1 on Evaluation-Board; green LEDs / high = link, low = no link
21... 20	<i>LED_gr_G[2..1]</i>	Link status for GE-Ports 2..1 on Evaluation-Board; green LEDs / high = link, low = no link
19... 12	<i>LED_ye_P[8..1]</i>	Port activity for FE-Ports 8..1 on Evaluation-Board; yellow LEDs / high = link, low = no link
11... 10	<i>LED_ye_G[2..1]</i>	Port activity for GE-Ports 2..1 on Evaluation-Board; yellow LEDs / high = link, low = no link
09... 02	<i>Tx_Enable_P[8..1]</i>	Enable signals for optical transceivers for FE-Ports 8..1; low=transceiver disabled, high = transceiver enabled
01... 00	<i>Tx_Enable_G[2..1]</i>	Enable signals for optical transceivers for GE-Ports 2..1; low=transceiver disabled, high = transceiver enabled

Table 3-6: SPI transmitted information (from the EESX module to a host system)

The transmitted information (like port status for LED indication for example) will be further processed by the host system.

The information in Table 3-7 can be read from the EESX module to support optical transceivers (SFP).



Bit	Signal name	Description
31... 24	<i>n_SFP_Present_P[8..1]</i>	Signal "SFP present" for FE-Ports 8..1 on Evaluation-Board; low = SFP module is present / high = SFP module is not present
23... 22	<i>n_SFP_Present_G[2..1]</i>	Signal "SFP present" for GE-Ports 2..1 on Evaluation-Board; low = SFP module is present / high = SFP module is not present
21... 00	not used	

Table 3-7: SPI received information (from a host system to the EESX module)

If the target application works without SPI – GPIO expansion then it is necessary to connect the *SPI\_MISO\_Aux* signal as follows...

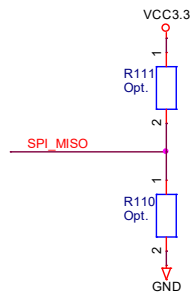

Figure 3-9: Alternative SPI implementation example

Configuration without SPI - GPIO Expansion (This applies to all Ports)		
Port 1..6	Tx - Mode (Copper) Fx - Mode (DSC/DST)  (without I2C Interface)	Fx - Mode (S  (with I2C Inte
Port 1..6	4..	-----

Table 3-8: Assembly information for alternative example

### 3.6 I2C Interface connection

For each Ethernet port there is one I2C bus connected to a SFP transceiver. This connection is only required for the 100Base-FX mode in which a SFP transceiver is used. This interface can be used to read transceiver status information, such as transceiver type, temperature, optical receive power and other information provided by the selected SFP transceiver.

In addition, the I2C\_Clk\_x pins are used to pre-set the port mode during start-up. If a high level is detected on the pin during start-up, the port will be set to fiber mode (100Base-FX), while the detection of a low level will set the port to copper mode (10/100Base-TX). To set the I2C\_Clk\_x line to a high level, connect a 4.7KOhm pull-up resistor to the VCC3.3 supply. To set the I2C\_Clk\_x line to a low level, do not connect this pin. There is an internal 47K pulldown resistor.

### 3.7 Host Device connection over an Ethernet Interface

This chapter describes connecting the EESX module to a host device. The application is approved only for port 6.

Devices for a galvanic separation are not present on the EESX module itself. Appropriate isolation can be achieved by using an external 1:1-Ethernet transformer.

If no electrical isolation is required, the module can also be connected directly to another Ethernet PHY device. In this case, capacitive coupling can be applied.

#### 3.7.1 Capacitive Coupling – 100Base-FX

The Ethernet signals TD-/+\_FX\_P\* and RD-/+\_FX\_P\* shall be coupled directly with a capacitor (100 nF) for all ports in FX-Mode (see *Figure 3-10*) if the capacitors are not implemented in the used SFP and 1\*9 transceivers.

On the host device side, the circuit is dependent of the used PHY component. Please refer to the data sheet of the appropriate PHY vendor.

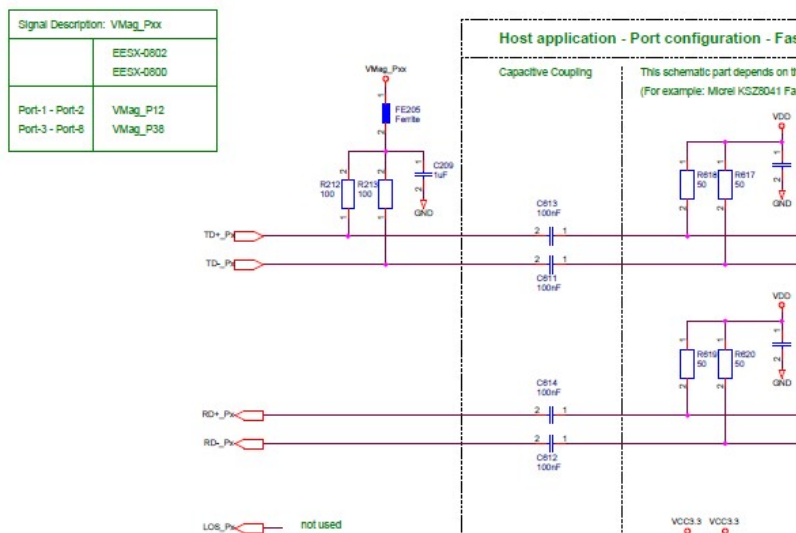

Figure 3-10: Capacitive Coupling - Circuit Diagram

#### 3.7.2 Magnetics Coupling – 10/100Base-TX

The Ethernet signals TD-/+\_TX\_P\* and RD-/+\_TX\_P\* shall be coupled with a magnetic transformer for all ports in TX-Mode (see *Figure 3-11*).

On the host device side, the circuit is dependent of the used PHY component. Please refer to the data sheet of the appropriate PHY vendor.

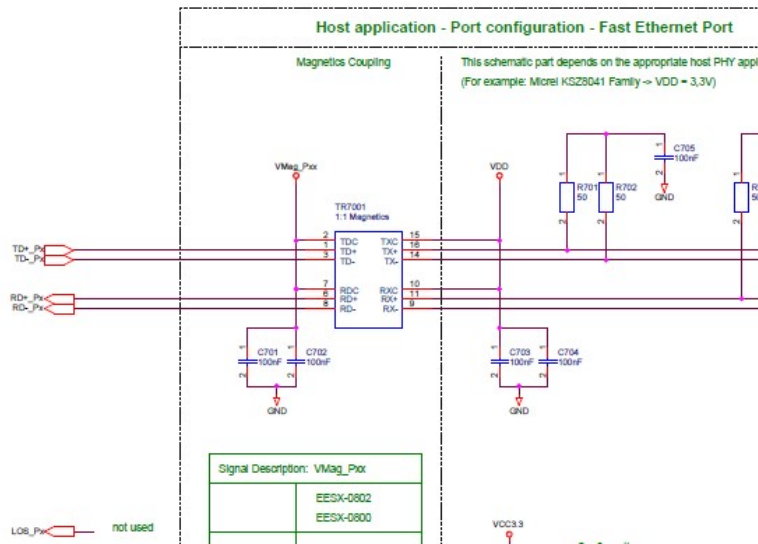

Figure 3-11: Magnetics Coupling - Circuit Diagram

### 3.7.3 Capacitive Coupling – 1000Base-FX

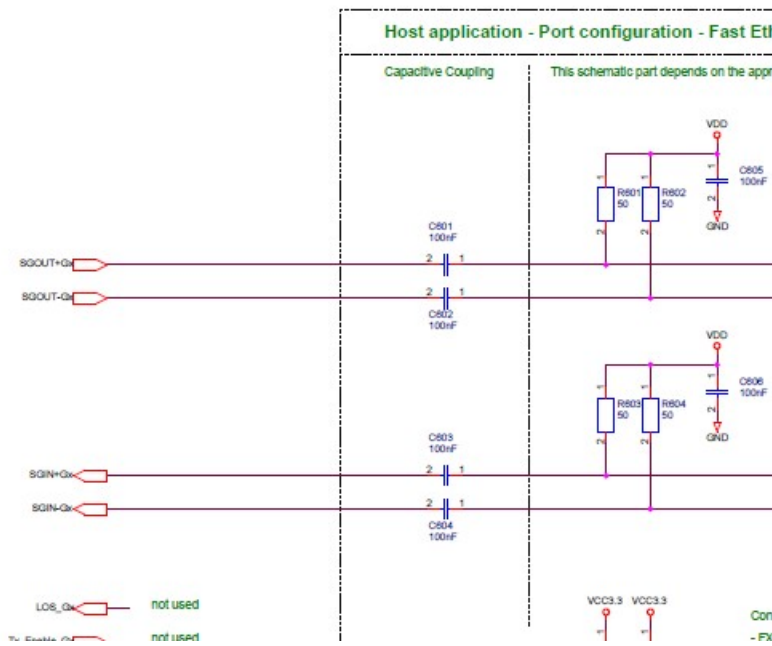

Figure 3-12: Capacitive Coupling - Circuit Diagram

### 3.7.4 Magnetics Coupling – 1000Base-TX

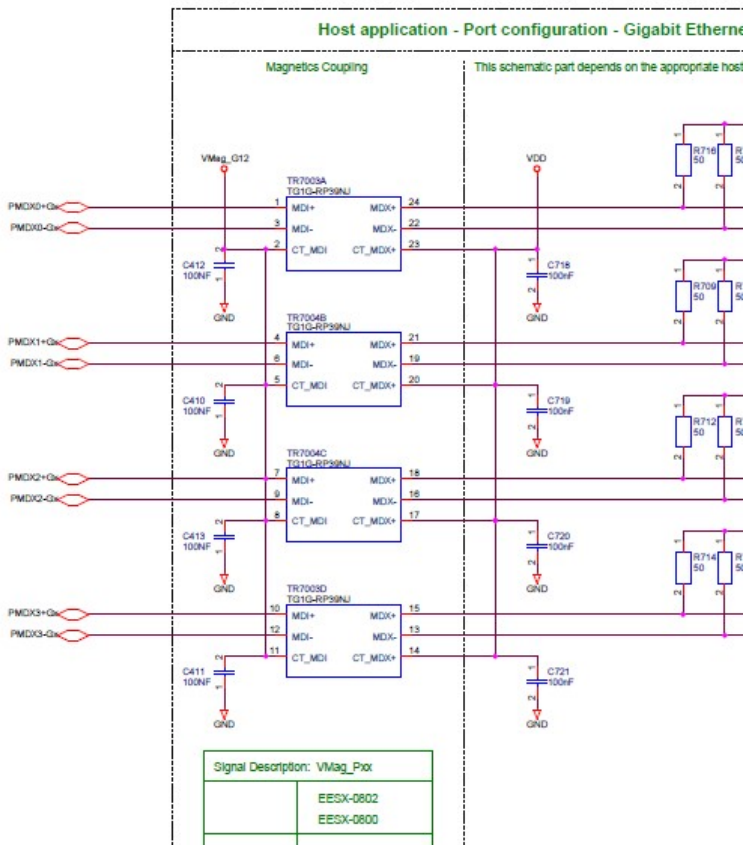

Figure 3-13: Capacitive Coupling - Circuit Diagram

### 3.8 Layout recommendations

Some recommendations to adapt the EESX-Evaluation-Board design to your application design.

#### A) Quick switches

- The mode switches SW403 and SW601 can be removed in customer's application design - if only using TX-OR FX- (SFP or DSC) Mode. (Without Mode switches connect the open nets to the correct net or potential).

Just as can be removed the (signal path) Quick switches IC701 up to IC708 for ports 1 to 4 and IC801 up to IC808 for ports 5 to 8. Connect the signal paths coming from the switching IC directly to the TX or FX port.

#### B) Ethernet Jack for twisted pair

- Use Ethernet Jacks with spring contacts for twisted pair copper mode to improve galvanic contact to metal housing due to EMC reasons.

#### C) Ethernet Jack with integrated transformer for twisted pair

- Use RJ45 Ethernet Jacks with integrated transformers to reduce space and to facilitate an easier electrical isolation on the PCB – if isolation of 2250 kV DC between Ethernet port signal contacts and potential of the EESX module (Ground and all other nets) according to IEEE standard 802.3 is required.

- For Instance the CO1502 at GE port 2 on EESX-Evaluation-Board has an integrated transformer for Gigabit- and Fast-Ethernet applications.

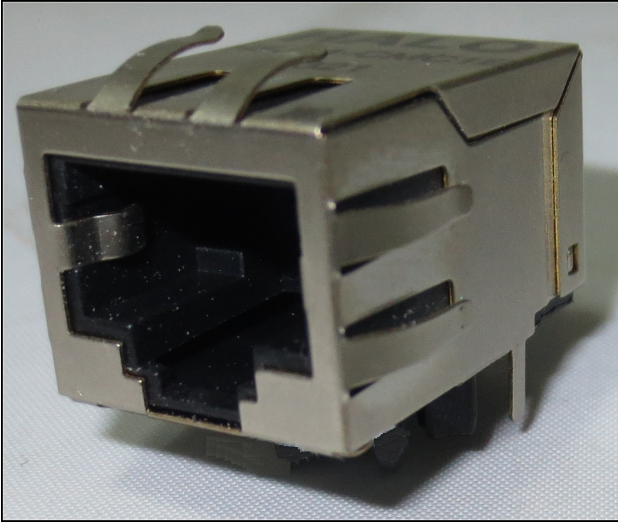

Figure 3-14: Single port RJ45 Ethernet Jack with integrated transformer and spring contacts

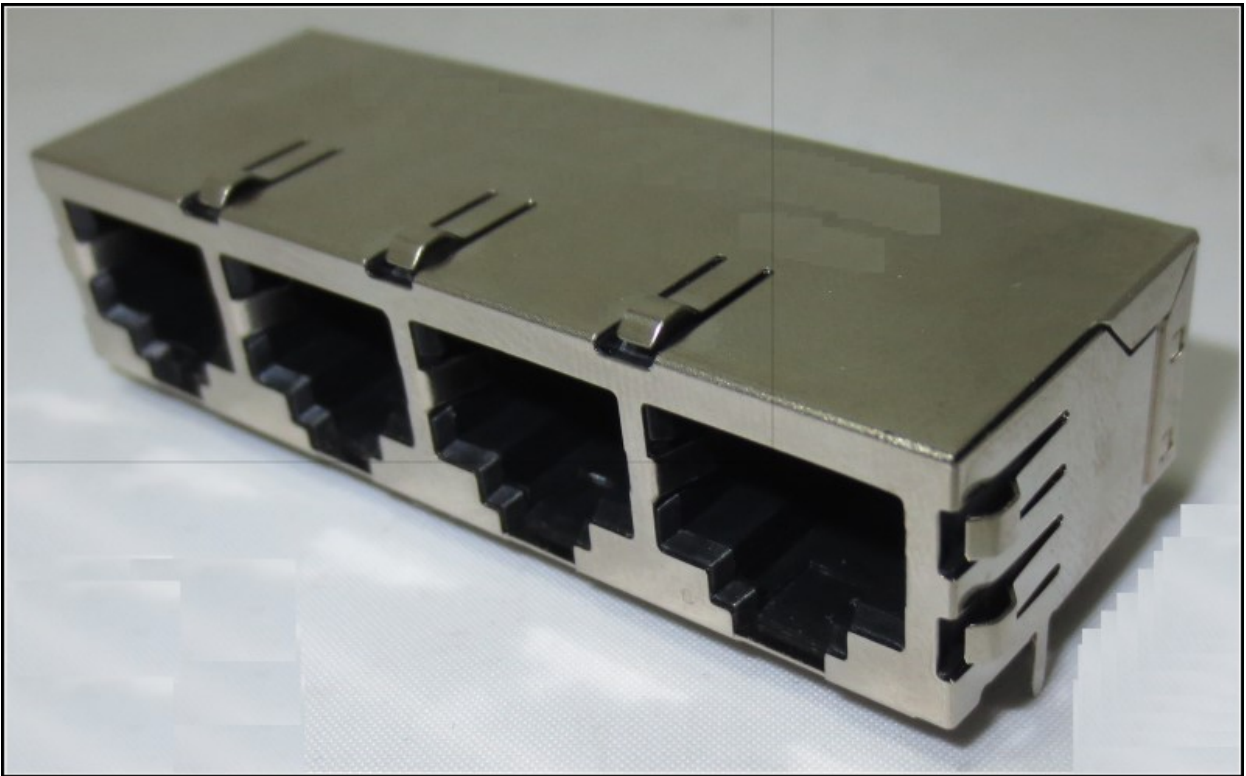

Figure 3-15: 4-port RJ45 Ethernet Jack with integrated transformers and spring contacts

### 3.9 Recommended Magnetic

Producer	Typ	Datarate	Temp. Range	Misc
HALO Electronics, Inc	TG110-HPE7N5LF	100Mbit/s	-40°C to 85°C	PoE+

## 4 Heat sink

### Case Temperature on the EESX-Board

**Note:** The Case temperature on the EESX module should not be exceeded!  
Case temperature for EESX20: 91°C  
Case temperature for EESX30: 85°C

#### 4.1 Permissible operating temperature

The maximum permissible operating temperature of the EESX module is +91 °C for EESX20 and +85°C for EESX30 at the measuring point of the Case Temperature. Operate the device only up to this maximum temperature.

The measuring point for the Case temperature of the EESX module is on the bottom side. See the following picture where the Case Temperature has to be measured on ESSX module.

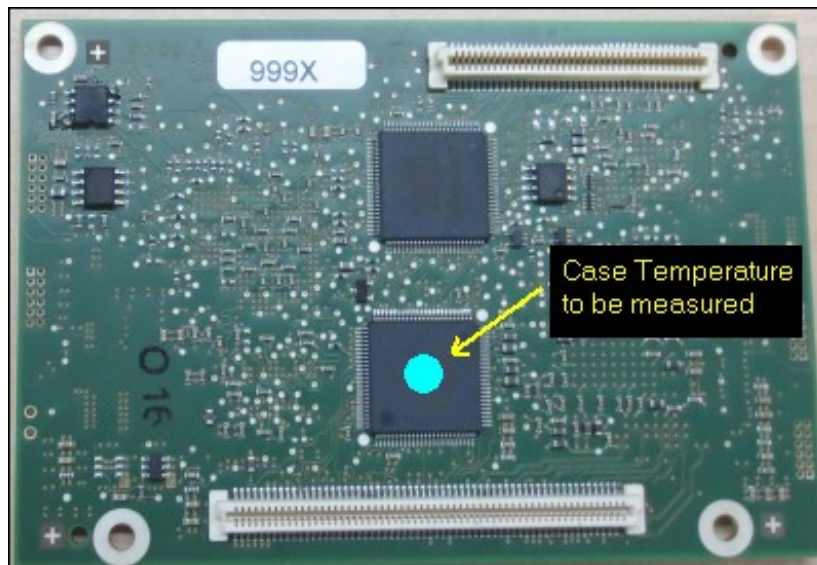

Figure 4-1: Measure Case temperature on the chip near the long connector

In case of exceeding the case temperature during operation an additional cooling will be necessary. The module will be offered also with a mounted cooling plate where an additional heat sink can be mounted on the top.

See details in chapter “Mechanics”.

## 4.2 Estimation of heat sink's cooling performance

To determine that the location is suitable for installing the device, perform a reference measurement:

- Install the device in the planned location.
- Switch on the device and wait until it has reached its operating temperature.
- Check whether the operating temperature at the measuring point remains below the maximum permissible value.
- If the operating temperature of the device exceeds the maximum permissible value, switch off the device and change the installation location, or provide additional cooling for the device.

WARNING

### **FIRE HAZARD**

Exceeding the maximum permissible operating temperature can cause the device to catch fire.

**Failure to follow these instructions can result in death, serious injury, or equipment damage.**

### **Example: Heat dissipation with a cooling element**

The following calculation delivers an estimated expected module temperature based on ambient temperature.

#### **Formula for estimating the device temperature with a cooling element:**

$$R_{th} \times P = \Delta T$$

$$\Delta T = T_{case} - T_{ambient}$$

#### Explanation of symbols:

$R_{th}$  Thermal resistance of the heat sink [K/W]

$P$  Thermal Power [W]

[K] Kelvin

[W] Watt

$\Delta T$  Temperature difference between case and ambient air [K]

$T_{case}$  Temperature of printed circuit board (Case Temperature at measuring point) [K]

$T_{ambient}$  Temperature of the ambient air [K]

## 5 Technical Data

Parameter	min.	typ.	max.	Unit
<b>Switch type</b> (Standard Ports)		Store- and- Forward		
<b>Latency</b> (end receive – begin transmit)				
10 Mbit; 64 ... 1518 Byte Paketlänge	5,0	7,8	10,0	µs
100 Mbit; 64 ... 1518 Byte Paketlänge	6,0	8,0	11,0	µs
1000 Mbit; 64 ... 1518 Byte Paketlänge	6,0	8,0	11,0	µs

Table 5-1: Switch parameter

### Electrical Specifications

Symbol	Description	min.	typ.	max.	Unit
VCC24	Supply voltage EESX-Evaluation-Board (DC)	+18	+24	+30	V
VCC3.3	Supply voltage EESX	3,3 - 5%	+3,3	+3,3 +5%	V
VCC3.3	Maximum Ripple EESX (AC)			+/- 50	mV <sub>pp</sub>
P <sub>IN</sub> (VCC3.3)	Power Consumption EESX module only			5	W
	EESX20			7	W
	EESX30				
P <sub>IN</sub> (VCC24)	Power Consumption EESX-Evaluation-Board with EESX30 module			8,1	W
	Tx mode			12,5	W
	Fx mode (depends from plugged SFP modules)				

Table 5-2: Power supply and power consumption

Tables 5-3 and 5-4 show port specification – Differential lines according to IEEE 802.3.

Parameter (Tx-Mode, 10Base-T)	min.	typ.	max.	Unit
Output signal by 100 Ω	2,2		2,8	V



Parameter (Tx-Mode, 100Base-Tx)	min.	typ.	Max.	Units
Output signal by 100 $\Omega$	0,95		1,05	V
Symmetry output signal	98		102	%
Parameter (Tx-Mode, 1000Base-Tx)	min.	typ.	Max.	Units
Output signal by 100 $\Omega$	0,95		1,05	V
Symmetry output signal	98		100	%

Table 5-3: Electrical specification Ethernet Tx lines

Parameter (Fx-Mode, 100/1000Base-Fx)	min.	typ.	Max.	Unit
Output signal by 100 $\Omega$ (Peak to peak)	0,5		2,4	$V_{pp}$
Output resistance		100		$\Omega$
Input resistance		100		$\Omega$

Table 5-4: Electrical Specification Ethernet Fx lines

Symbol	Description	min.	typ.	max.	Unit
$f_{max\ SPI}$	Clock Frequency SPI		1	16	MHz
$t_{su}$ (Setup time)	SPI_MOSI before SPI_Clk $\uparrow$	40			ns
	SPI_Clk $\uparrow$ before SPI_En1 $\uparrow$	40			ns
	SPI_En2 before SPI_Clk $\uparrow$	40			ns
	SPI_MISO before SPI_Clk $\downarrow$	20			ns
	Parallel Data Input before SPI_En2 $\uparrow$	20			ns
$t_h$ (Hold time)	SPI_MOSI after SPI_Clk $\uparrow$	20			ns
	SPI_MISO after SPI_Clk $\downarrow$	20			ns
	Parallel Data Input after SPI_En2 $\uparrow$	20			ns
$t_{pd}$ (Output Delay)	SPI_MOSI after SPI_Clk $\uparrow$		$0,5 \times 1/f_{max}$		ns
	SPI_MISO after SPI_Clk $\uparrow$	0		20	ns

Table 5-5: Timing Specification SPI

Parameter	min.	typ.	max.	Unit
Storage temperature	-40		+80	°C
Humidity (non-condensing) preliminary	10		85	%
Air-pressure by operating	795 (+2000 m a.s.l.)			hPa
Air-pressure by storage preliminary	620 (+4000 m a.s.l.)			hPa

Table 5-6: Miscellaneous

### Board Weights

Name	Net weight
EESX20	42 g
EESX30	42 g
EESX-Evaluation-Board	370 g

Table 5-7: Board Weights

### Ambient Air Temperature

#### EESX20/30 module

Product	Comment
<b>Operating Ambient Air Temperature</b>	
EESX20/30 module	- 40°C (16h) <sup>1)</sup> + 85°C (16h) <sup>1)</sup>
<b>Non Operating Ambient Air Temperature</b>	
EESX20/30 module	- 40°C (16h) <sup>1)</sup> + 85°C (16h) <sup>1)</sup>
<b>Damp Heat</b>	
EESX20/30 module	+ 55 °C/ + 25 °C, 12h – 12h, 2 cycles

Table 5-8: Ambient temperature conditions (tested on EESX-Evaluation-Board)

**Note:** The items marked with <sup>1)</sup> means ambient air temperature.

#### EESX-Evaluation-Board

Product	Comment
<b>Operating Ambient Air Temperature</b>	
EESX-Evaluation-Board	+ 5°C <sup>1)</sup> + 40°C <sup>1)</sup>
<b>Non Operating Ambient Air Temperature</b>	
EESX-Evaluation-Board	- 40°C (16h) <sup>1)</sup> + 85°C (16h) <sup>1)</sup>

**Note:** The items marked with <sup>1)</sup> means ambient air temperature.

Parts on EESX20/30 module or EESX-Evaluation-Board should not touched in operation!  
Due to possible hot spots of electronical components – especially the case of integrated circuits.

**MTBF**

<b>Product Standard</b>	<b>Comment</b>
<b>MTBF Value</b>	
EESX20	207,4 years Gb 25°C 87,2 years Gb 60°C
EESX30	198,6 years Gb 25°C 85,1 years Gb 60°C

*Table 5-9: MTBF values of the EESX module according Telcordia SR332*

## 6 Further Support

### Technical Questions

For technical questions, please contact any Hirschmann dealer in your area or Hirschmann directly.

You find the addresses of our partners on the Internet at <http://www.hirschmann.com>.

A list of local telephone numbers and email addresses for technical support directly from Hirschmann is available at <https://hirschmann-support.belden.com>.

This site also includes a free of charge knowledge base and a software download section.

### Customer Innovation Center

The Customer Innovation Center is ahead of its competitors on three counts with its complete range of innovative services:

- Consulting incorporates comprehensive technical advice, from system evaluation through network planning to project planning.
- Training offers you an introduction to the basics, product briefing and user training with certification. You find the training courses on technology and products currently available at <https://www.belden.com/solutions/customer-innovation-center>.
- Support ranges from the first installation through the standby service to maintenance concepts.

With the Customer Innovation Center, you decide against making any compromises in any case. Our client-customized package leaves you free to choose the service components you want to use.

Internet:

<https://www.belden.com/solutions/customer-innovation-center>