



HIRSCHMANN

A **BELDEN** BRAND

User Manual

Installation

Modular Industrial Gigabit Ethernet Backbone Switch

DRAGON MACH Family

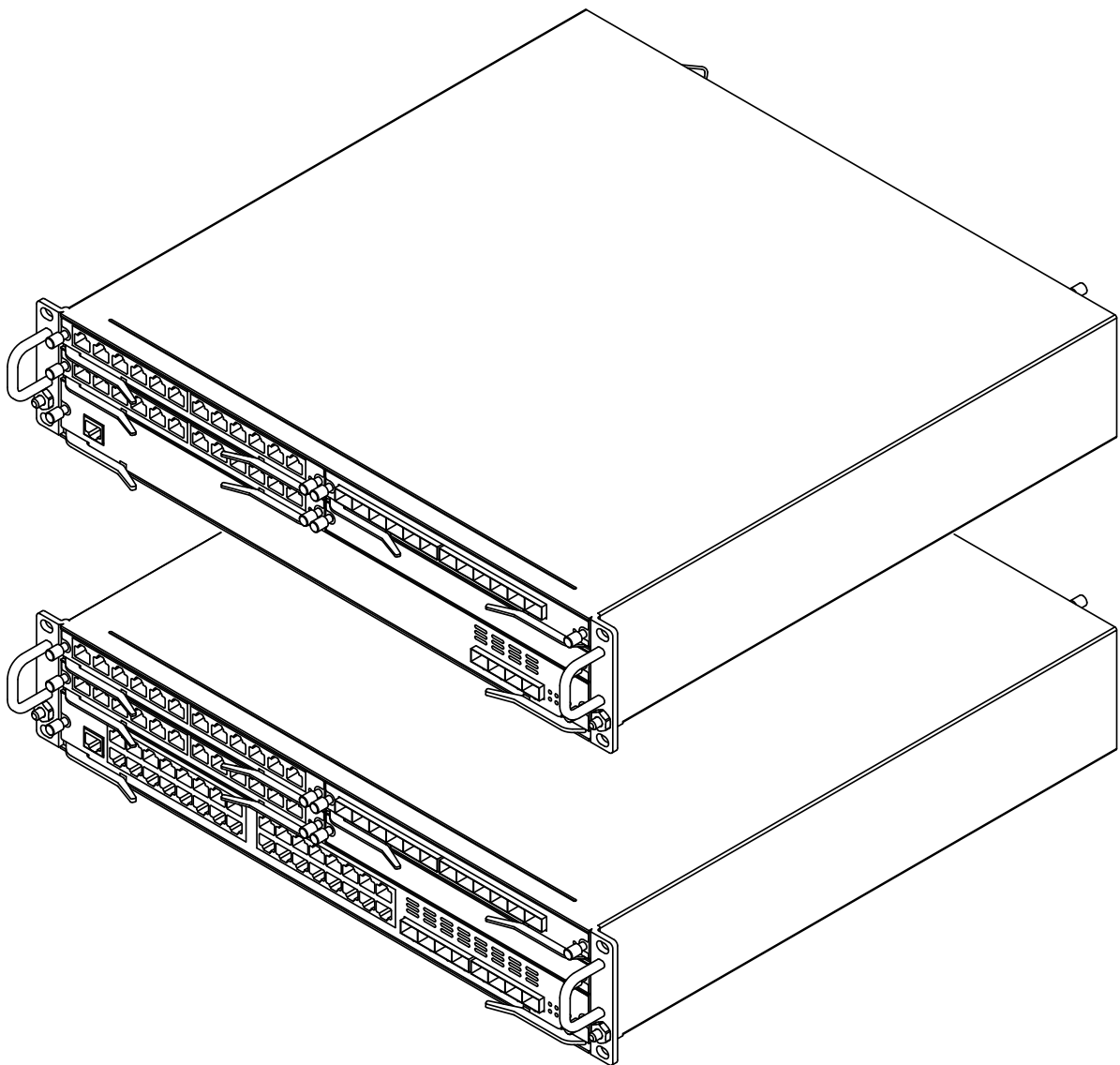

The naming of copyrighted trademarks in this manual, even when not specially indicated, should not be taken to mean that these names may be considered as free in the sense of the trademark and tradename protection law and hence that they may be freely used by anyone.

© 2021 Hirschmann Automation and Control GmbH

Manuals and software are protected by copyright. All rights reserved. The copying, reproduction, translation, conversion into any electronic medium or machine scannable form is not permitted, either in whole or in part. An exception is the preparation of a backup copy of the software for your own use.

The performance features described here are binding only if they have been expressly agreed when the contract was made. This document was produced by Hirschmann Automation and Control GmbH according to the best of the company's knowledge. Hirschmann reserves the right to change the contents of this document without prior notice. Hirschmann can give no guarantee in respect of the correctness or accuracy of the information in this document.

Hirschmann can accept no responsibility for damages, resulting from the use of the network components or the associated operating software. In addition, we refer to the conditions of use specified in the license contract.

You can get the latest version of this manual on the Internet at the Hirschmann product site (www.hirschmann.com).

Hirschmann Automation and Control GmbH
Stuttgarter Str. 45-51
72654 Neckartenzlingen
Germany

Contents

Important information	7
Safety instructions	9
About this Manual	16
Key	17
1 Description	18
1.1 General device description	18
1.1.1 Basic device	18
1.1.2 Media modules	19
1.1.3 Power supply unit module	19
1.1.4 Fan module	20
1.2 Device views	21
1.2.1 Media modules	24
1.2.2 Power supply unit module	25
1.2.3 Fan module	25
1.3 Power supply	26
1.3.1 Power supply modules	26
1.3.2 Media module D4K-10TP-PoE	28
1.4 Signal contact	29
1.5 Ethernet ports	29
1.5.1 10/100/1000 Mbit/s twisted pair port	30
1.5.2 100/1000 Mbit/s F/O port	30
1.5.3 1/2.5/10 Gbit/s F/O port	31
1.5.4 Support of PoE	31
1.5.5 Out-of-band management port	32
1.6 Display elements	33
1.6.1 Device state	33
1.6.2 PSU module status	37
1.6.3 Port status	38
1.6.4 Management interface status	39
1.6.5 Media module status	41
1.7 Management interfaces	44

1.7.1	V.24 interface (external management)	44
1.7.2	USB interface	45
1.7.3	SD card interface	46
2	Installation	47
2.1	Checking the package contents	47
2.2	Installing the SD card (optional)	47
2.3	Installing a cover panel (optional)	49
2.4	Installing a power supply module	50
2.5	Installing a media module (optional)	51
2.6	Mounting the fan module	52
2.7	Installing and grounding the device	54
2.8	Wiring and mounting the signal contact (optional)	56
2.9	Connecting the supply voltage	58
2.9.1	Power supply modules	58
2.9.2	Media module D4K-10TP-PoE	60
2.10	Installing an SFP transceiver (optional)	61
2.11	Operating the device	61
2.12	Connecting data cables	62
3	Making basic settings	63
4	Monitoring the ambient air temperature	65
5	Maintenance and service	66
6	Disassembly	67
6.1	De-installing a power supply module	67
6.2	Removing a fan module	68
6.3	Removing a media module	69
6.4	Removing an SFP transceiver (optional)	70
6.5	Removing the device	71
7	Technical data	72
7.1	General data	72
7.1.1	Basic device	72

7.1.2	Power supply unit module	72
7.1.3	Fan module	72
7.1.4	Media modules	72
7.2	Supply voltage	73
7.2.1	Power supply modules	73
7.2.2	Media module D4K-10TP-PoE	73
7.3	Signal contact	74
7.4	Power consumption/power output	74
7.5	Climatic conditions during operation	75
7.6	Climatic conditions during storage	75
7.7	Dimension drawings	76
7.7.1	Basic device	76
7.7.2	Power supply unit module	77
7.7.3	Fan module	77
7.7.4	Media modules	78
7.8	EMC and immunity	79
7.9	Network range	81
7.9.1	10/100/1000 Mbit/s twisted pair port	81
7.9.2	Fast Ethernet SFP transceiver	82
7.9.3	Bidirectional Fast Ethernet SFP transceiver	83
7.9.4	Gigabit Ethernet SFP transceiver	83
7.9.5	Bidirectional Gigabit Ethernet SFP transceiver	85
7.9.6	2.5 Gigabit Ethernet SFP transceiver	86
7.9.7	10 Gigabit Ethernet SFP+ transceiver	86
8	Scope of delivery	88
8.1	Basic device	88
8.2	Media modules	88
8.3	Power supply units	88
8.4	Fan module	88
9	Order numbers	89
10	Accessories	90

11	Underlying technical standards	93
A	Further support	94

Important information

Note: Read these instructions carefully, and familiarize yourself with the device before trying to install, operate, or maintain it. The following notes may appear throughout this documentation or on the device. These notes warn of potential hazards or call attention to information that clarifies or simplifies a procedure.

■ Symbol explanation



This is a general warning symbol. This symbol alerts you to potential personal injury hazards. Observe all safety notes that follow this symbol to avoid possible injury or death.



If this symbol is displayed in addition to a safety instruction of the type “Danger” or “Warning”, it means that there is a danger of electric shock and failure to observe the instructions will inevitably result in injury.



This symbol indicates the danger of hot surfaces on the device. In connection with safety instructions, non-observance of the instructions will inevitably result in injuries.



DANGER

DANGER draws attention to an immediately dangerous situation, which will **inevitably** result in a serious or fatal accident if not observed.



WARNING

WARNING indicates a potentially hazardous situation which, if not avoided, **could** result in death or serious injury.



CAUTION

CAUTION indicates a possible danger which, if not avoided, **may** result in minor injuries.

NOTICE

NOTE provides information about procedures that do not involve the risk of injury.

Safety instructions



WARNING

UNCONTROLLED MACHINE ACTIONS

To avoid uncontrolled machine actions caused by data loss, configure all the data transmission devices individually.

Before you start any machine which is controlled via data transmission, be sure to complete the configuration of all data transmission devices.

Failure to follow these instructions can result in death, serious injury, or equipment damage.

■ General safety instructions

You operate this device with electricity. Improper usage of the device entails the risk of physical injury or significant property damage. The proper and safe operation of this device depends on proper handling during transportation, proper storage and installation, and careful operation and maintenance procedures.

- Before connecting any cable, read this document, and the safety instructions and warnings.
- Operate the device with undamaged components exclusively.
- The device is free of any service components. In case of a damaged or malfunctioning device, turn off the supply voltage and return the device to Hirschmann for inspection.

■ Correct usage

Only use the device for those purposes specified in the catalog and in the technical description. Only operate the device with external devices and components that are recommended and permitted by the manufacturer. The proper and safe operation of this product depends on proper handling during transport, proper storage, assembly and installation, and conscientious operation and maintenance procedures.

■ National and international safety regulations

Verify that the electrical installation meets local or nationally applicable safety regulations.

■ Installation site requirements

Operate the device only at the specified ambient temperature (temperature of the ambient air at a distance of 5 cm (2 in) from the device) and at the specified relative humidity.

- ▶ When you are selecting the installation location, make sure you observe the climatic threshold values specified in the technical data.
- ▶ Use the device in an environment with a maximum pollution degree that complies with the specifications in the technical data.

■ Strain relief

Note: If the strain relief is insufficient, there is a potential risk of torsion, contact problems and creeping interruptions.

- Relieve the connection points of cables and lines from mechanical stress.
- Design strain reliefs in such a way that they help prevent any mechanical damage to cables, wires or conductors caused by external influences or their own weight.
- To help prevent damage to device connections, connectors and cables, follow the instructions for proper installation in accordance with DIN VDE 0100-520:2013-06, sections 522.6, 522.7 and 522.13.

■ Qualification requirements for personnel

- Only allow qualified personnel to work on the device.

Qualified personnel have the following characteristics:

- ▶ Qualified personnel are properly trained. Training as well as practical knowledge and experience make up their qualifications. This is the prerequisite for grounding and labeling circuits, devices, and systems in accordance with current standards in safety technology.
- ▶ Qualified personnel are aware of the dangers that exist in their work.
- ▶ Qualified personnel are familiar with appropriate measures against these hazards in order to reduce the risk for themselves and others.
- ▶ Qualified personnel receive training on a regular basis.

■ Device casing

Only technicians authorized by the manufacturer are permitted to open the casing.

- Keep the ventilation slits free to ensure good air circulation.
- Make sure there is at least 10 cm (3.94 in) of space in front of the ventilation slits of the casing.
- Do not touch the housing during operation or shortly after switching off the device. Hot surfaces can cause injury.
- Exclusively mount the device horizontally in a switch cabinet.
[See “Installing and grounding the device” on page 54.](#)
- Operating the device in the maximum surrounding air temperature and stacking devices: When installing the device, make sure there is at least 1 free rack space (approx. 5 cm (2 in)) above the device, because heat is discharged via the housing of the device.
- If you are operating the device in a 19" switch cabinet: install sliding/mounting rails for supporting the weight of the device.
- Exclusively use the device with a fan module.
- Fans are subject to natural wear. If one or more fans in the fan module fail, function and lifetime of a device can be negatively affected or the device may fail completely. Use the monitoring functions of the device for individual fans and temperature. Depending on your installation conditions, it may be possible to continue operating your device after one fan has failed.

Check the temperature measured by your device: In the Command Line Interface, use the command: show temperature; in the Graphical User Interface (GUI) in the Basic settings dialog: System, Temperature. The displayed temperature must not exceed the maximum value.

[See “Climatic conditions during operation” on page 75.](#)

- The device may overheat if the fan module fails or is removed. Switch off the device or replace the fan module within 2 minutes, otherwise failures or damage to the device may occur.
- After removing the fan module during active operation, the individual fans continue to spin for a few seconds. Do not touch rotating fan blades. Do not insert objects into rotating fan blades.

■ Shielded ground

The shielded ground wire of the twisted pairs cables is connected to the front panel as a conductor.

Beware of possible short circuits when connecting a cable section with conductive shield braiding.

■ Grounding the device

The device has 2 protective ground connections.

The device is grounded via one of the two grounding nuts and in addition via the power supply connection (built-in non-heating device plug C14 according to IEC 60320-1).

- Ground the device before connecting any other cables.
- Disconnect the grounding only after disconnecting all other cables.

■ Requirements for connecting electrical wires

Before connecting the electrical wires, **always** verify that the requirements listed are complied with.

The following requirements apply without restrictions:

- ▶ The electrical wires are voltage-free.
- ▶ The cables used are permitted for the temperature range of the application case.
- ▶ Before you set up other connections, connect one of the two ground connections on the front side of the device with the protective conductor. When removing connections, remove the protective conductor last.
- ▶ Exclusively switch on the device when it is installed.
- ▶ Relevant for North America:
Exclusively use 60/75 °C (140/167 °F) or 75 °C (167 °F) copper (Cu) wire.

Table 1: Requirements for connecting electrical wires

■ Requirements for connecting the signal contact

The following requirements apply without restrictions:

- ▶ Limit the connected voltage with a current limitation or in accordance with its application. Observe the electrical threshold values for the signal contact.
[See "Signal contact" on page 74.](#)

Table 2: Requirements for connecting the signal contact

■ Requirements for connecting the supply voltage

Device variant Prerequisites:

Basic device	<p>All of the following requirements are complied with:</p> <ul style="list-style-type: none"> ▶ The supply voltage corresponds to the voltage specified on the type plate of the device. ▶ The power supply conforms to overvoltage category I or II. ▶ The power supply has an easily accessible disconnecting device (for example a switch or a plug). This disconnecting device is clearly identified. So in the case of an emergency, it is clear which disconnecting device belongs to which power supply cable. ▶ The wire diameter of the power supply cable is at least 0.75 mm² (North America: AWG18) on the supply voltage input. ▶ The cross-section of the ground conductor is the same size as or bigger than the cross-section of the power supply cables. ▶ Use a power supply cable which is suitable for the voltage, the current and the physical load.
Media module D4K-10TP-PoE	<p>The supply voltage input is designed for operation with safety extra-low voltage. Exclusively connect ES1 circuits with voltage limitations according to IEC/EN 62368-1 or SELV circuits with voltage limitations according to IEC/EN 60950-1 to the supply voltage connection.</p> <p>Verify that the connected supply voltage meets the requirements of IEEE 802.3bt:</p> <ul style="list-style-type: none"> ▶ Rated voltage: 54 V DC Max. voltage range: 52 V DC ... 57 V DC ▶ The power supply is potential-free. For power supply modules capable of PoE, exclusively use a potential-free SELV power supply.

Table 3: Requirements for connecting the supply voltage

■ LED or laser components

LED or LASER components according to IEC 60825-1 (2014):

CLASS 1 LASER PRODUCT

CLASS 1 LED PRODUCT

■ CE marking

The labeled devices comply with the regulations contained in the following European directive(s):

2011/65/EU and 2015/863/EU (RoHS)

Directive of the European Parliament and of the Council on the restriction of the use of certain hazardous substances in electrical and electronic equipment.

2014/30/EU (EMC)

Directive of the European Parliament and of the Council on the harmonisation of the laws of the Member States relating to electromagnetic compatibility.

2014/35/EU

Directive of the European Parliament and of the Council on the harmonisation of the laws of the Member States relating to the making available on the market of electrical equipment designed for use within certain voltage limits.

In accordance with the above-named EU directive(s), the EU conformity declaration will be at the disposal of the relevant authorities at the following address:

Hirschmann Automation and Control GmbH
Stuttgarter Str. 45-51
72654 Neckartenzlingen
Germany
www.hirschmann.com

The product can be used in the industrial sector.

- ▶ Interference immunity: EN 61000-6-2
- ▶ Emitted interference: EN 55032
- ▶ Safety: EN 61010

Warning! This is a class A device. This device can cause interference in living areas, and in this case the operator may be required to take appropriate measures.

Note: The assembly guidelines provided in these instructions must be strictly adhered to in order to observe the EMC threshold values.

■ ESD Guidelines

The modules are equipped with electrostatically sensitive components. These can be destroyed, or their life cycles reduced, by the effects of an electrical field or by a charge equalization if the connections are touched. You will find information about electrostatically endangered assemblies in DIN EN 61340-5-1 (2007-08) and DIN EN 61340-5-2 (2007-08).

■ FCC note

Supplier's Declaration of Conformity
47 CFR § 2.1077 Compliance Information

DRAGON MACH4000
DRAGON MACH4500; D4K-AIR; D4K-PSU-300W-HV; D4K-12SFP;
D4K-10TP-POE; D4K-12TP-RJ45

U.S. Contact Information

Belden – St. Louis
1 N. Brentwood Blvd. 15th Floor
St. Louis, Missouri 63105, United States
Phone: 314.854.8000

This device complies with part 15 of the FCC Rules. Operation is subject to the following two conditions: (1) This device may not cause harmful interference, and (2) this device must accept any interference received, including interference that may cause undesired operation.

Note: This equipment has been tested and found to comply with the limits for a Class A digital device, pursuant to part 15 of the FCC Rules. These limits are designed to provide reasonable protection against harmful interference when the equipment is operated in a commercial environment. This equipment generates, uses, and can radiate radio frequency energy and, if not installed and used in accordance with the instruction manual, may cause harmful interference to radio communications. Operation of this equipment in a residential area is likely to cause harmful interference in which case the user will be required to correct the interference at his own expense.

■ Recycling note

After usage, this device must be disposed of properly as electronic waste, in accordance with the current disposal regulations of your county, state, and country.

■ Approvals

PoE media module D4K-10TP-PoE is not UL 60950-1 approved.

If one or more PoE media modules D4K-10TP-PoE are used in the basic device DRAGON MACH4500, the UL 60950-1 approval for the basic device expires.

The basic device DRAGON MACH4500 exclusively has an approval according to UL 60950-1 if all modules of the basic device DRAGON MACH4500 have this approval.

About this Manual

The “Installation” user manual contains a device description, safety instructions, a description of the display, and the other information that you need to install the device.

Documentation mentioned in the “User Manual Installation” that is not supplied with your device as a printout can be found as PDF files for downloading on the Internet at: <https://www.doc.hirschmann.com>

Key

The symbols used in this manual have the following meanings:

▶	Listing
□	Work step
■	Subheading

1 Description

1.1 General device description

The devices are designed for the special requirements of industrial automation. They meet the relevant industry standards, provide very high operational reliability, even under extreme conditions, and also long-term reliability and flexibility.

The device allows you to set up switched Industrial Ethernet networks according to standard IEEE 802.3.

1.1.1 Basic device

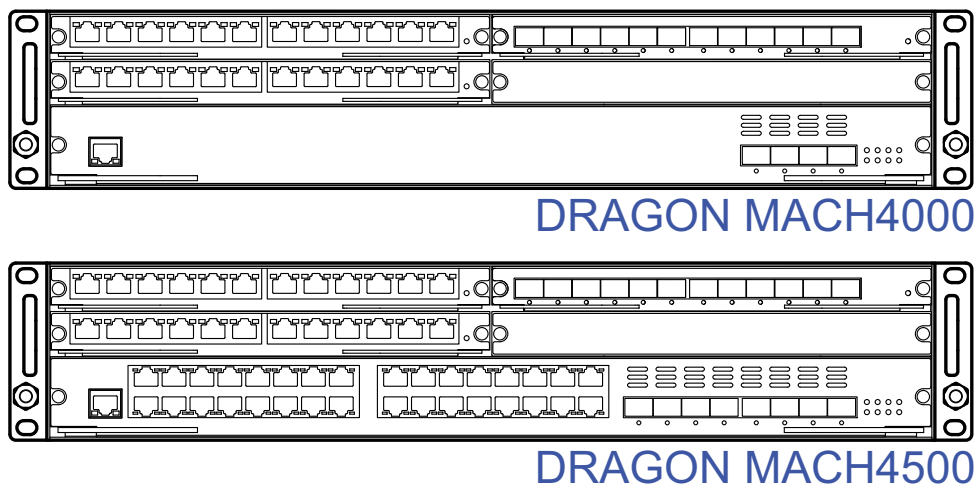

Figure 1: Basic device: DRAGON MACH4000 and DRAGON MACH4500

You can choose from a wide range of variants. You have the option to set up your device individually based on different criteria:

- ▶ Number of ports
- ▶ Transmission speed
- ▶ Types of connectors
- ▶ Certifications

You have numerous options of combining the device characteristics. You can determine the possible combinations using the configurator which is available in the Belden Online Catalog <https://catalog.belden.com> on the web page of the device.

1.1.2 Media modules

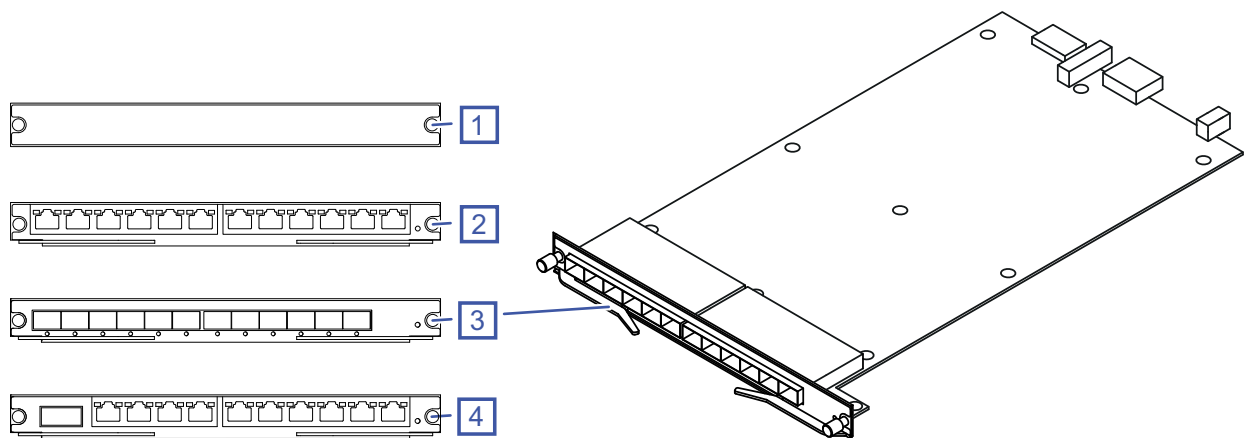

Figure 2: Media modules: Cover panel (1), D4K-12TP-RJ45 (2), D4K-12SFP (3), D4K-10TP-PoE (4)

You have the option to supplement your basic device with up to 4 media modules. Each media module offers 12 additional Fast/Gigabit Ethernet ports or 10 Fast/Gigabit Ethernet ports with PoE.

Seal unused slots with cover panels.

You obtain the media modules as accessories.

See [“Order numbers” on page 89](#).

Note: PoE media module D4K-10TP-PoE is not UL 60950-1 approved. If one or more PoE media modules D4K-10TP-PoE are used in the basic device DRAGON MACH4500, the UL 60950-1 approval for the basic device expires.

The basic device DRAGON MACH4500 exclusively has an approval according to UL 60950-1 if all modules of the basic device DRAGON MACH4500 have this approval.

1.1.3 Power supply unit module

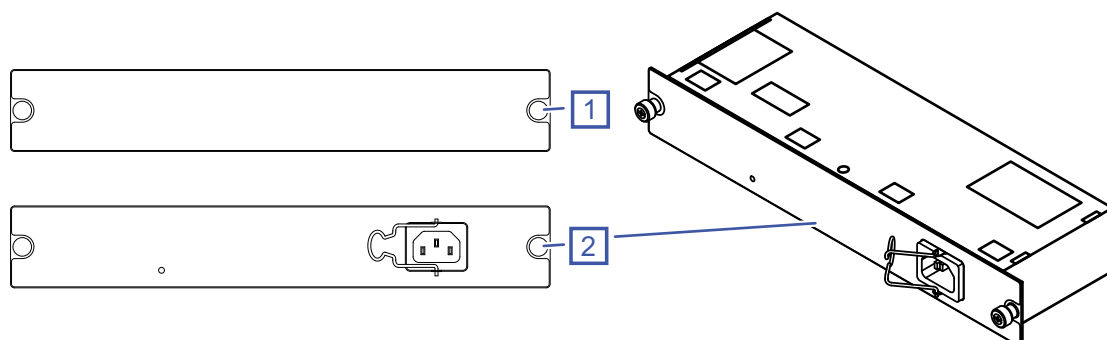

Figure 3: PSU module: Cover panel (1), D4K-PSU-300W-HV (2)

You have the option to operate your basic device non-redundantly with 1 PSU module or redundantly with 2 PSU modules.

Seal unused slots with cover panels.
You obtain the power supply modules as accessories.
[See “Order numbers” on page 89.](#)

1.1.4 Fan module

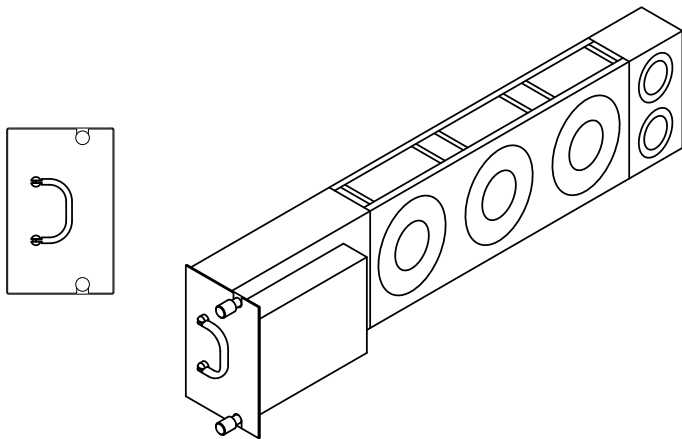
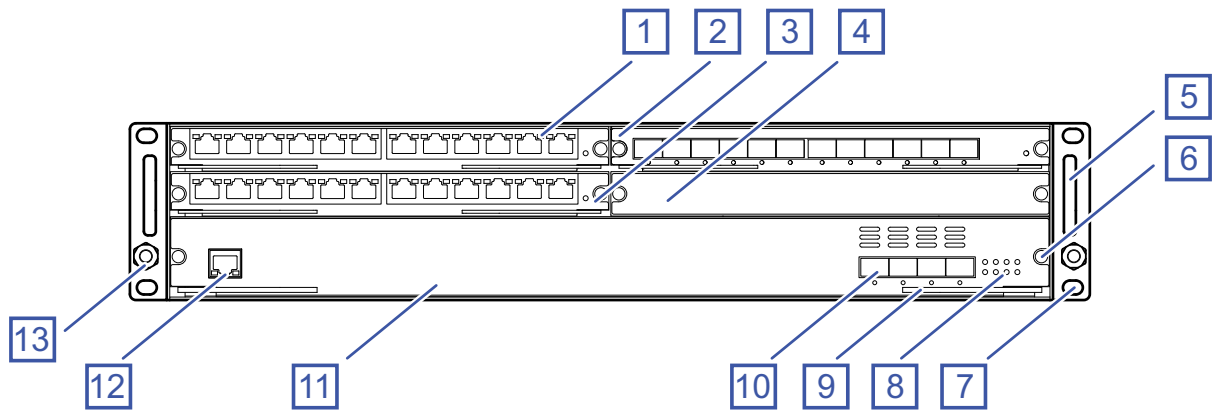

Figure 4: Fan module: D4K-AIR

The basic device requires 1 fan module to dissipate heat.
You obtain additional fan modules as accessories.
[See “Order numbers” on page 89.](#)

1.2 Device views

■ MACH4000



Front view

1	Slot 1	Example: Media module D4K-12TP-RJ45
2	Slot 2	Example: Media module D4K-12SFP
3	Slot 3	Example: Media module D4K-12TP-RJ45
4	Slot 4	Example: Cover panel for media module slot
5	Mounting handle	
6	Screw with loss prevention	
7	Oblong hole	
8	LED display elements for device status	
9	Locking lever	
10	4 × SFP slot for 1/2.5/10 Gbit/s connections (Fast Ethernet not supported)	
11	Main Switching Unit (MSU)	
12	Out-of-band management port	
13	Ground connection	

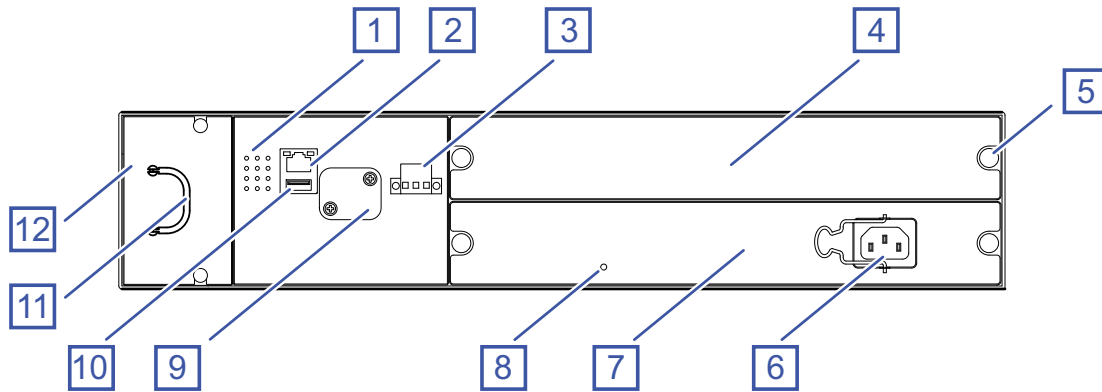

Rear view

1	LED display elements for device status
2	V.24 interface
3	Connection for the signal contact
4	PSU module Slot 1 Example: Cover panel for power supply module slot
5	Screw with loss prevention
6	Supply voltage connection
7	PSU module Slot 2 Example: D4K-PSU-300W-HV
8	LED display element PSU module status
9	Slot for the SD card
10	USB interface
11	Mounting handle
12	Fan module Example: D4K-AIR

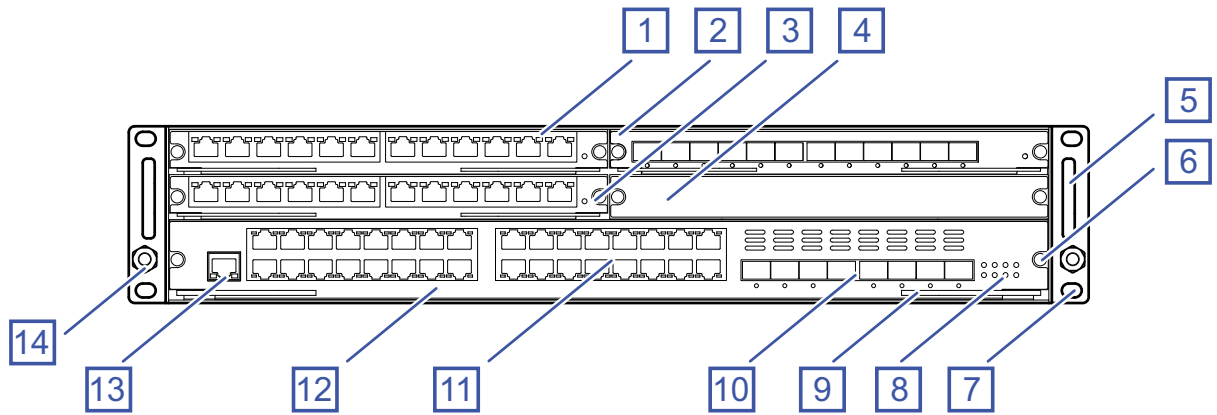

Front view

1	Slot 1	Example: Media module D4K-12TP-RJ45
2	Slot 2	Example: Media module D4K-12SFP
3	Slot 3	Example: Media module D4K-12TP-RJ45
4	Slot 4	Example: Cover panel for media module slot
5	Mounting handle	
6	Screw with loss prevention	
7	Oblong hole	
8	LED display elements for device status	
9	Locking lever	
10	8 × SFP slot for 1/2.5/10 Gbit/s connections (Fast Ethernet not supported)	
11	32 × RJ45 socket for 10/100/1000 Mbit/s Twisted Pair connections	
12	Main Switching Unit (MSU)	
13	Out-of-band management port	
14	Ground connection	

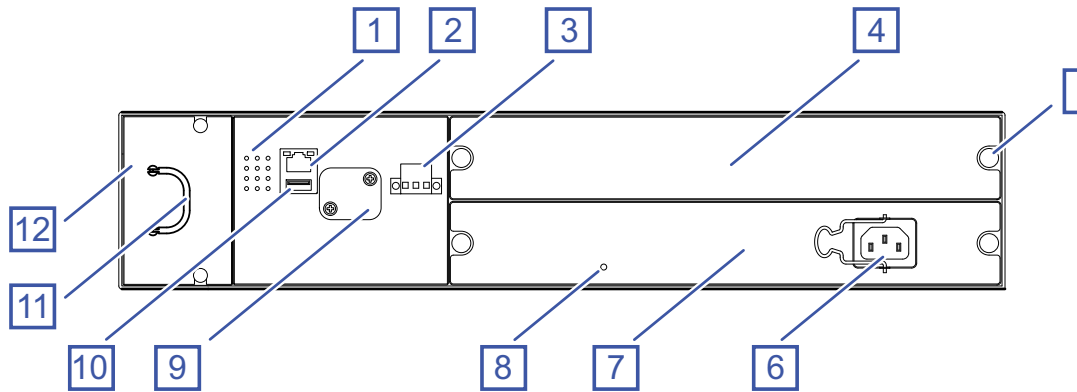

Rear view

1	LED display elements for device status	
2	V.24 interface	
3	Connection for the signal contact	
4	PSU module Slot 1	Example: Cover panel for power supply module slot
5	Screw with loss prevention	
6	Supply voltage connection	
7	PSU module Slot 2	Example: Power supply module D4K-PSU-300W-HV
8	LED display element	PSU module status
9	Slot for the SD card	
10	USB interface	
11	Mounting handle	
12	Fan module	

1.2.1 Media modules

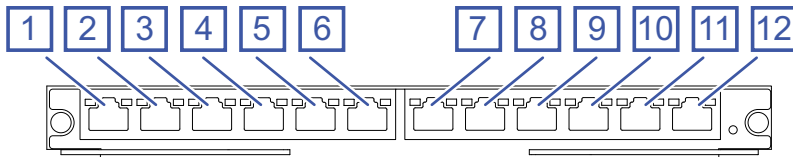

D4K-12TP-RJ45

Port	Port description
1 ... 12	12 × RJ45 socket for 10/100/1000 Mbit/s Twisted Pair connections

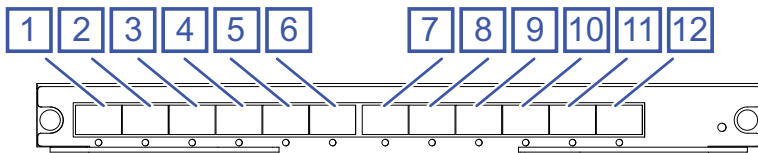

D4K-12SFP

Port	Port description
1 ... 12	12 × SFP slot for 100/1000 Mbit/s fiber optic connections

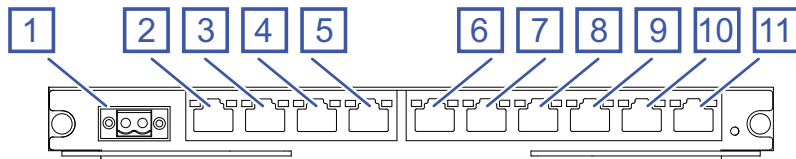

D4K-10TP-PoE

- | | | |
|----------|------|---|
| 1 | 1 × | 2-pin terminal block for the PoE supply voltage |
| 2 ... 11 | 10 × | RJ45 socket for 10/100/1000 Mbit/s PoE PD connections |

1.2.2 Power supply unit module

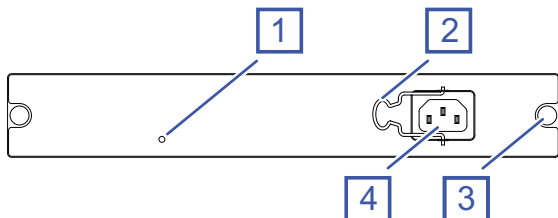

D4K-PSU-300W-HV

- | | | |
|---|---|-------------------------------------|
| 1 | LED display element | PSU module status |
| 2 | Safety catch for non-heating device cable connector | (removable) |
| 3 | Screw with loss prevention | |
| 4 | Built-in non-heating device plug | (C14 plug according to IEC 60320-1) |

1.2.3 Fan module

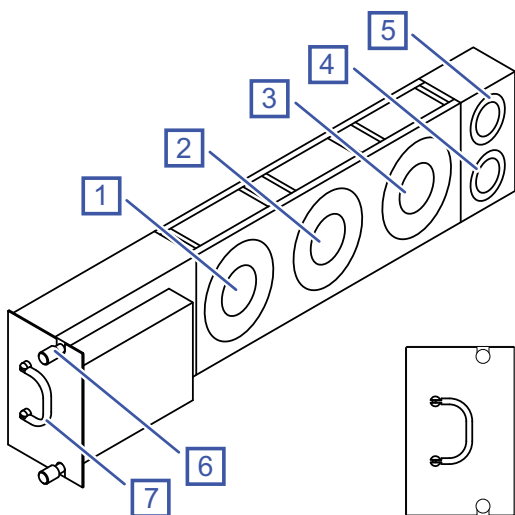

D4K-AIR

- | | |
|---|----------------------------|
| 1 | Fan 1 |
| 2 | Fan 2 |
| 3 | Fan 3 |
| 4 | Fan 4 |
| 5 | Fan 5 |
| 6 | Screw with loss prevention |
| 7 | Mounting handle |

1.3 Power supply

1.3.1 Power supply modules

You have the following options to supply your device with voltage:

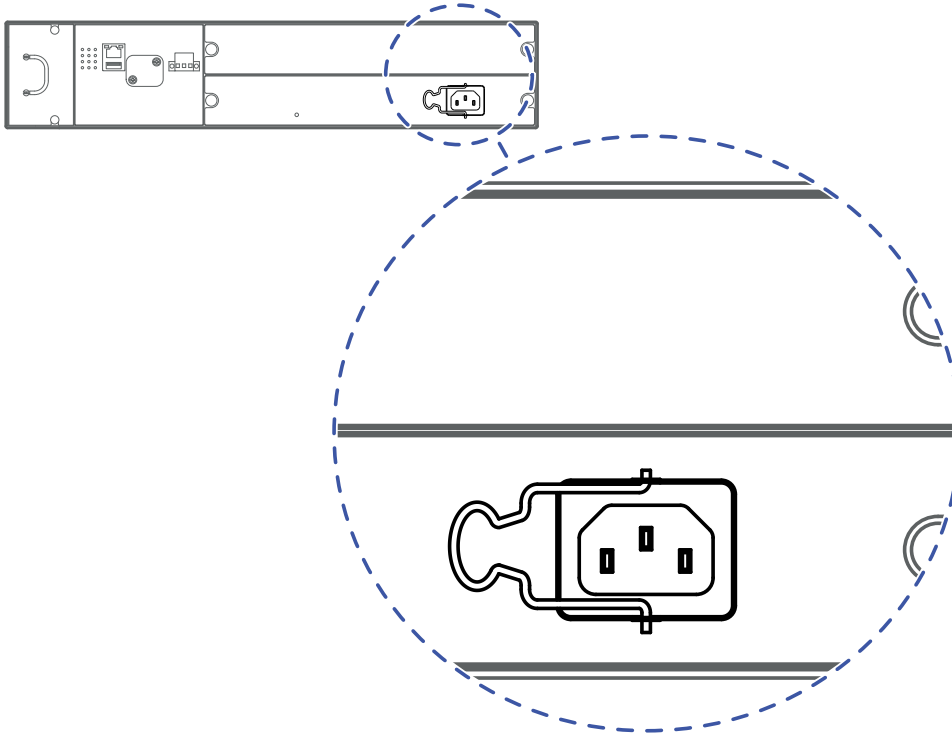

Figure 5: Power supply: PSU modules (rear side of device)

- ▶ Non-redundantly via 1 PSU module with built-in non-heating device plug (C14 plug according to IEC 60320-1)

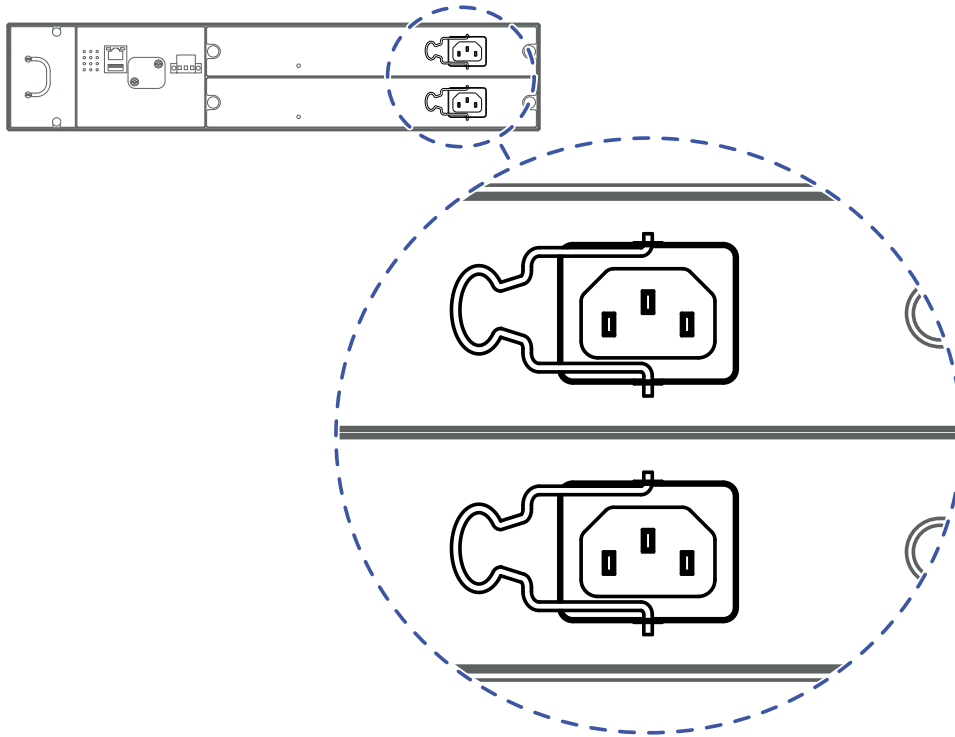

Figure 6: Power supply: PSU modules (rear side of device)

- ▶ Redundantly via 2 PSU modules with built-in non-heating device plug (C14 plug according to IEC 60320-1)

1.3.2 Media module D4K-10TP-PoE

The media module D4K-10TP-PoE enables the supply of terminal devices with PoE voltage via twisted pair cable.

To supply the module with PoE voltage you need an external power supply unit.

Details about the power supply of the media module can be found in chapter [“Supply voltage” on page 73](#).

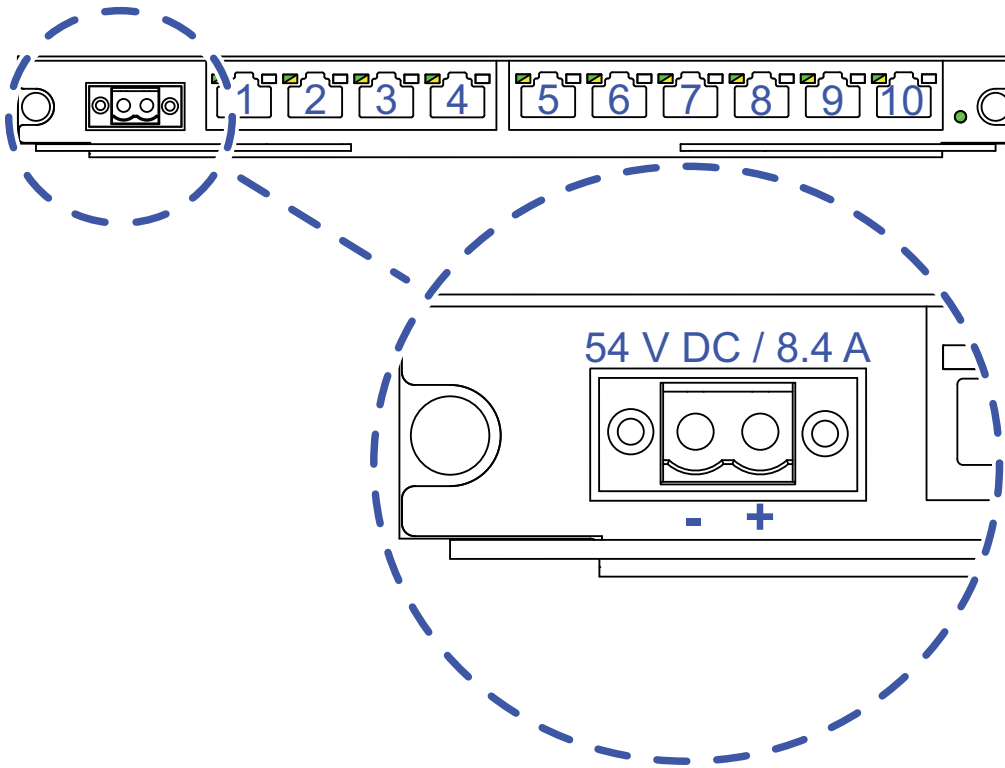

Figure 7: Power supply: Terminal block on the media module

1.4 Signal contact

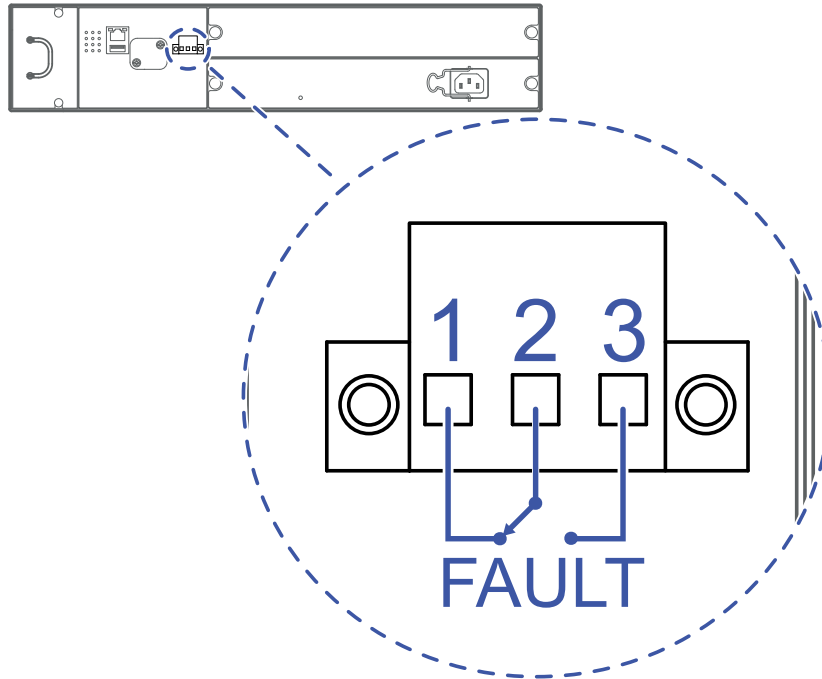

Figure 8: Signal contact: 3-pin terminal block with screw lock; position on the device (rear side of the device)

Signal contact

1	NC	Normally closed contact
2	CO	Changeover contact
3	NO	Normally open contact

The signal contact is a potential-free changeover contact. If the device is not connected to a power supply, the changeover contact (2) is connected to the normally closed contact (1) (see figure 8).

The signal contact allows you to control external devices or monitor device functions.

In the configuration, you specify how the device uses the signal contact. You will find detailed information on possible applications and the configuration of the signal contact in the software user documentation. You will find the software user documentation as PDF files on the Internet at: <https://www.doc.hirschmann.com>

1.5 Ethernet ports

You can connect end devices and other segments to the device and media module ports using twisted pair cables or optical fibers (F/O).

1.5.1 10/100/1000 Mbit/s twisted pair port

This port is an RJ45 socket.

The 10/100/1000 Mbit/s twisted pair port allows you to connect network components according to the IEEE 802.3 10BASE-T/100BASE-TX/1000BASE-T standard.

This port supports:

- ▶ Autonegotiation
- ▶ Autopolarity
- ▶ Autocrossing (if autonegotiation is activated)
- ▶ 1000 Mbit/s full duplex
- ▶ 100 Mbit/s half-duplex mode, 100 Mbit/s full duplex mode
- ▶ 10 Mbit/s half-duplex mode, 10 Mbit/s full duplex mode

Delivery state: Autonegotiation activated

■ Pin assignments

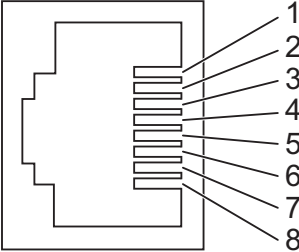
RJ45	Pin	10/100 Mbit/s	1000 Mbit/s
	MDI mode		
	1	TX+	BI_DA+
	2	TX-	BI_DA-
	3	RX+	BI_DB+
	4	—	BI_DC+
	5	—	BI_DC-
	6	RX-	BI_DB-
	7	—	BI_DD+
	8	—	BI_DD-
	MDI-X mode		
	1	RX+	BI_DB+
	2	RX-	BI_DB-
	3	TX+	BI_DA+
	4	—	BI_DD+
	5	—	BI_DD-
	6	TX-	BI_DA-
7	—	BI_DC+	
8	—	BI_DC-	

1.5.2 100/1000 Mbit/s F/O port

This port is an SFP slot.

The 100/1000 Mbit/s F/O port allows you to connect network components according to the IEEE 802.3 100BASE-FX/1000BASE-SX/1000BASE-LX standard.

This port supports:

- ▶ 1000 Mbit/s full duplex
- ▶ 100 Mbit/s half-duplex mode, 100 Mbit/s full duplex mode

Delivery state:

- ▶ 100 Mbit/s full duplex when using a Fast Ethernet SFP transceiver
- ▶ 1000 Mbit/s full duplex when using a Gigabit Ethernet SFP transceiver

1.5.3 1/2.5/10 Gbit/s F/O port

This port is an SFP slot.

The port allows you to connect network components according to the IEEE 802.3 (Clause 49) 10GBASE-R standard.

The port allows you to connect network components according to IEEE P802.3bz 2.5 Gbit/s.

This port supports:

Full duplex mode

Delivery state:

1/2.5/10 Gbit/s full duplex when using a Gigabit Ethernet SFP transceiver

1.5.4 Support of PoE

Prerequisites for the support of PoE/PoE+:

- ▶ At least 1 media module with PoE/PoE+ functionality (D4K-10TP-PoE) is mounted in the basic device.

Note: PoE/PoE+ is exclusively available with PoE-capable media modules. The DRAGON basic device has no PoE-capable ports.

Note: Connect only PoE-powered devices whose data connections are located in the interior of the building and are specified as SELV circuits according to IEC 60950-1 or ES1 circuits according to IEC/EN 62368-1.

The 10/100/1000 Mbit/s PoE port allows you to connect a network component as a PoE power source according to standards IEEE 802.3 10BASE-T/100BASE-TX/1000BASE-T and IEEE 802.3bt.

The 10/100/1000 Mbit/s PoE port supports Class 0 ... Class 4 (PoE, PoE+) according to IEEE 802.3bt.

The individual ports are not electrically insulated from each other (common PoE voltage).

The PoE power is supplied via the wire pairs transmitting the signal (phantom voltage).

You will find more information here:

[See "Technical data" on page 72.](#)

■ Pin assignment

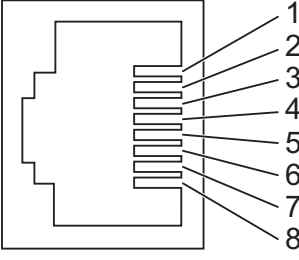
RJ45	Pin	10/100 Mbit/s	1000 Mbit/s	PoE ^a
	MDI-X mode			
	1	RX+	BI_DB+	Positive V_{PSE}
	2	RX-	BI_DB-	Positive V_{PSE}
	3	TX+	BI_DA+	Negative V_{PSE}
	4	—	BI_DD+	—
	5	—	BI_DD-	—
	6	TX-	BI_DA-	Negative V_{PSE}
	7	—	BI_DC+	—
8	—	BI_DC-	—	

a. Exclusively for media modules with PoE functionality.

1.5.5 Out-of-band management port

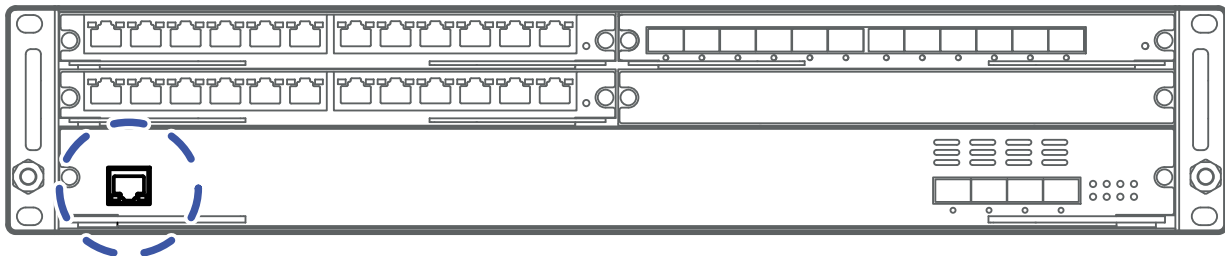

Figure 9: Out-of-Band management port: RJ45 port; location on the device (front side of the device)

This port is an RJ45 socket.

The port allows you to connect network components according to the IEEE 802.3 100BASE-TX standard.

This port supports:

- ▶ 100 Mbit/s half duplex,
- ▶ 100 Mbit/s full duplex

The port allows you to manage the device and upload configurations via the following protocols:

- ▶ SNMP
- ▶ SSH
- ▶ Telnet
- ▶ FTP
- ▶ SCP
- ▶ HTTP/HTTPS

For more information see the “Command Line Interface” reference manual. You find the manual available as download on the Internet at:

www.doc.hirschmann.com

1.6 Display elements

After the supply voltage is set up, the Software starts and initializes the device. Afterwards, the device performs a self-test. During this process, various LEDs light up.

1.6.1 Device state

These LEDs provide information about conditions which affect the operation of the whole device.

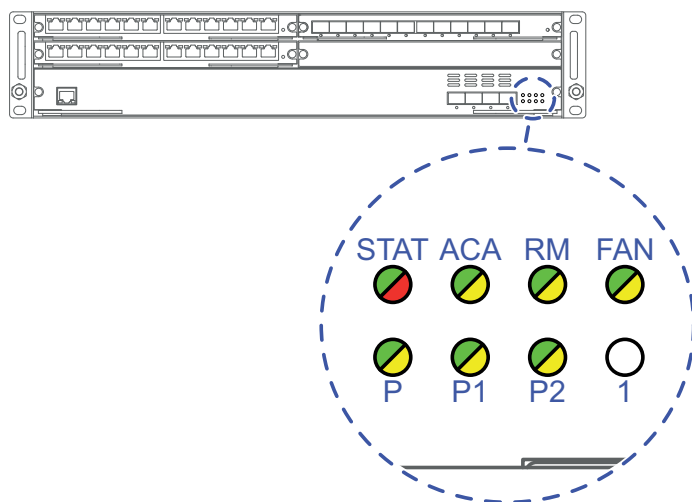

Figure 10: Device status: Location of the display elements on the device (front side of the device)

LED	Display	Color	Activity	Meaning
STAT	Device Status	—	none	Device is starting and/or is not ready for operation.
		green	lights up	Device is ready for operation. Characteristics can be configured
		red	lights up	Device is ready for operation. Device has detected at least one error in the monitoring results
			flashes 1 time a period	The boot parameters used when the device has been started differ from the boot parameters saved. Start the device again.
			flashes 4 times a period	Device has detected a multiple IP address
ACA	Storage medium ACA22 ACA31	—	none	ACA storage medium not connected
		green	lights up	ACA storage medium connected
			flashes 3 times a period	Device writes to/reads from the storage medium
		yellow	lights up	ACA storage medium inoperative

LED	Display	Color	Activity	Meaning
RM	Ring Manager	—	none	No redundancy configured
		green	lights up	Redundancy exists
			flashes 1 time a period	Device is reporting an incorrect configuration of the RM function
yellow	lights up	No redundancy exists		
FAN	Fan module	—	none	No fan module present
		green	lights up	All individual fans of the fan module are operational.
		yellow	lights up	At least one individual fan of the fan module is not operational.
P	Supply voltage	—	none	Supply voltage is too low
		yellow	lights up	Supply voltage 1 or 2 is on
			flashes 4 times a period	Software update is running. Maintain the power supply.
green	lights up	Supply voltage 1 and 2 is on		
P1	Supply voltage	—	none	At least one of the following cases applies: <ul style="list-style-type: none"> ▶ Power supply module is not connected to slot P1. ▶ There is no external supply voltage or it is too low. ▶ No connection between PSU module and basic device.
		green	lights up	The following applies: <ul style="list-style-type: none"> ▶ Power supply module is connected to slot P1. ▶ Valid supply voltage connected. ▶ Boot procedure started
P2	Supply voltage	—	none	At least one of the following cases applies: <ul style="list-style-type: none"> ▶ Power supply module is not connected to slot P2. ▶ There is no external supply voltage or it is too low. ▶ No connection between PSU module and basic device.
		green	lights up	The following applies: <ul style="list-style-type: none"> ▶ Power supply module is connected to slot P2. ▶ Valid supply voltage connected. ▶ Boot procedure started
1	Reserved	—	none	No function in the existing device version.

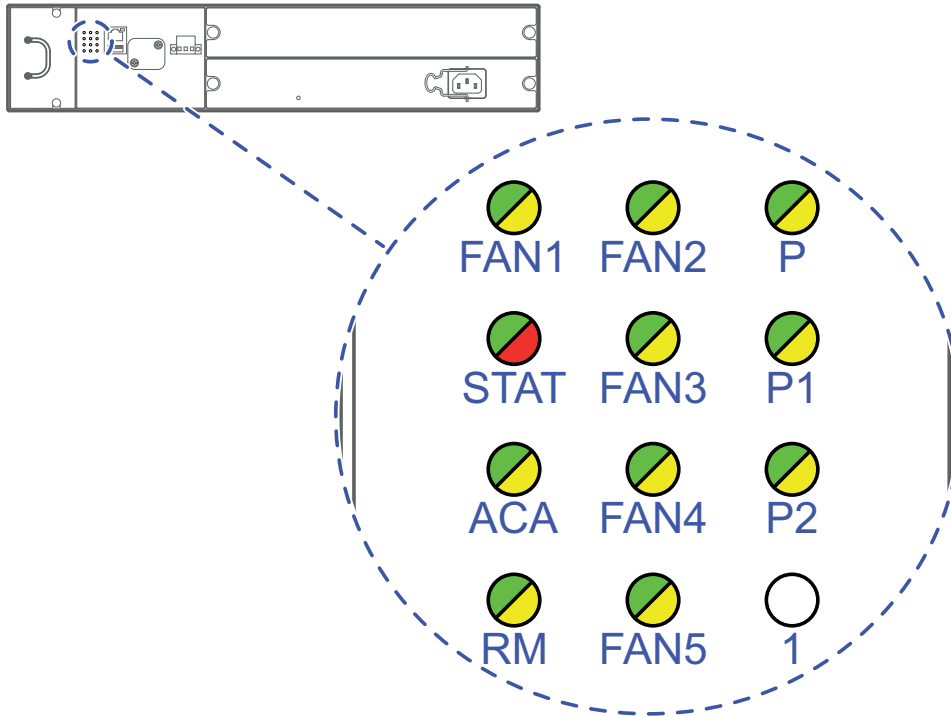

Figure 11: Device status: Location of the display elements on the device (rear side of the device)

LED	Display	Color	Activity	Meaning
STAT	Device Status	—	none	Device is starting and/or is not ready for operation.
		green	lights up	Device is ready for operation. Characteristics can be configured
		red	lights up	Device is ready for operation. Device has detected at least one error in the monitoring results
			flashes 1 time a period	The boot parameters used when the device has been started differ from the boot parameters saved. Start the device again.
			flashes 4 times a period	Device has detected a multiple IP address
ACA	Storage medium ACA22 ACA31	—	none	ACA storage medium not connected
		green	lights up	ACA storage medium connected
			flashes 3 times a period	Device writes to/reads from the storage medium
		yellow	lights up	ACA storage medium inoperative
RM	Ring Manager	—	none	No redundancy configured
		green	lights up	Redundancy exists
			flashes 1 time a period	Device is reporting an incorrect configuration of the RM function
		yellow	lights up	No redundancy exists
FAN 1 ... 5	Individual fan status	—	none	Fan X not operational.
		green	lights up	Fan X operational.

LED	Display	Color	Activity	Meaning
P	Supply voltage	—	none	Supply voltage is too low
		yellow	lights up	Supply voltage 1 or 2 is on
			flashes 4 times a period	Software update is running. Maintain the power supply.
		green	lights up	Supply voltage 1 and 2 is on
P1	Supply voltage	—	none	At least one of the following cases applies: <ul style="list-style-type: none"> ▶ Power supply module is not connected to slot P1. ▶ There is no external supply voltage or it is too low. ▶ No connection between PSU module and basic device.
			green	lights up
P2	Supply voltage	—	none	At least one of the following cases applies: <ul style="list-style-type: none"> ▶ Power supply module is not connected to slot P2. ▶ There is no external supply voltage or it is too low. ▶ No connection between PSU module and basic device.
			green	lights up
1	Reserved	—	none	No function in the existing device version.

1.6.2 PSU module status

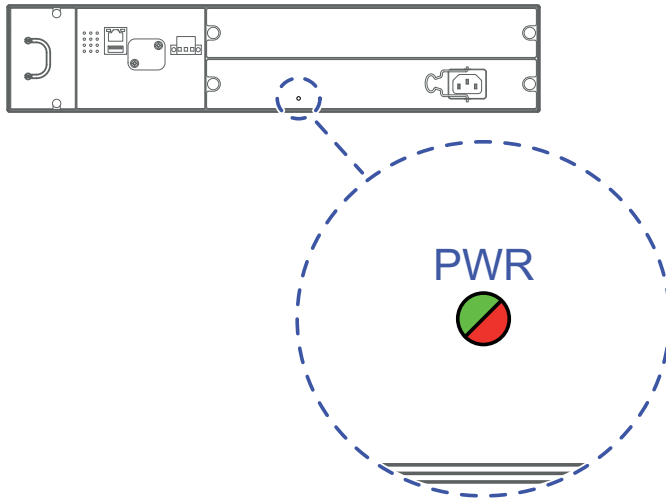

Figure 12: PSU module status: Location of the display elements on the device (rear side of the device)

LED	Display	Color	Activity	Meaning
PWR	Supply voltage	—	none	At least one of the following cases applies: <ul style="list-style-type: none"> ▶ PSU module is not plugged in. ▶ There is no external supply voltage or it is too low. ▶ No connection between PSU module and basic device. ▶ PSU module not operational.
		green	lights up	At least one of the following cases applies: <ul style="list-style-type: none"> ▶ PSU module is plugged in. ▶ Valid supply voltage connected.
		red	flashes 1 time a period	At least one of the following cases applies: <ul style="list-style-type: none"> ▶ Supply voltage is too low ▶ Supply voltage too high ▶ PSU module fan failed ▶ Overheating warning
		green/ red	flashing alternately	Overload current protection mode The PSU leaves the overload current protection mode when the supply voltage drops back into the permitted range. See “Supply voltage” on page 73.

1.6.3 Port status

These LEDs provide port-related information.

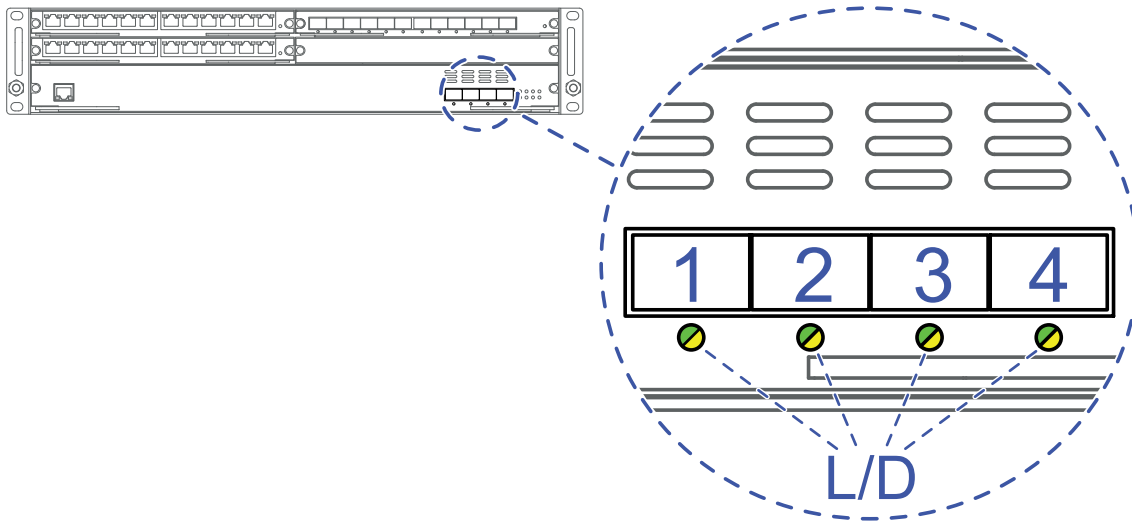

Figure 13: Port status: Location of the display elements on the device (front side of the device)

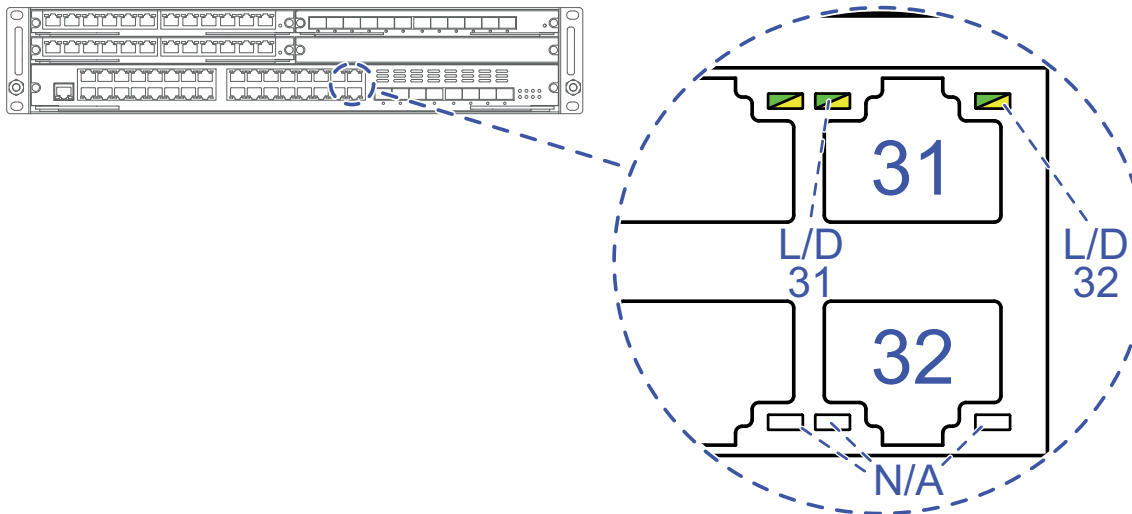

Figure 14: Port status: location of the display elements on the device (front side of the device)

Note: In the present hardware version, the lower port LEDs of the RJ45 ports are without function (N/A). The port status of all ports is displayed via the upper port LEDs.

LED	Display	Color	Activity	Meaning
L/D	Link state/data traffic	—	none	Device detects an invalid or missing link
		green	lights up	Device detects a valid link
			flashes 1 time a period	Port is switched to stand-by
			flashes 3 times a period	Port is switched off
		yellow	lights up	Device detects a non-supported SFP transceiver or a non-supported data rate
			flashing alternately	Device is transmitting and/or receiving data
			flashes 1 time a period	Device detects at least one unauthorized MAC address (Port Security Violation) and sends a trap.
			flashes 3 times a period	The device deactivates the relevant port (auto-deactivation).

1.6.4 Management interface status

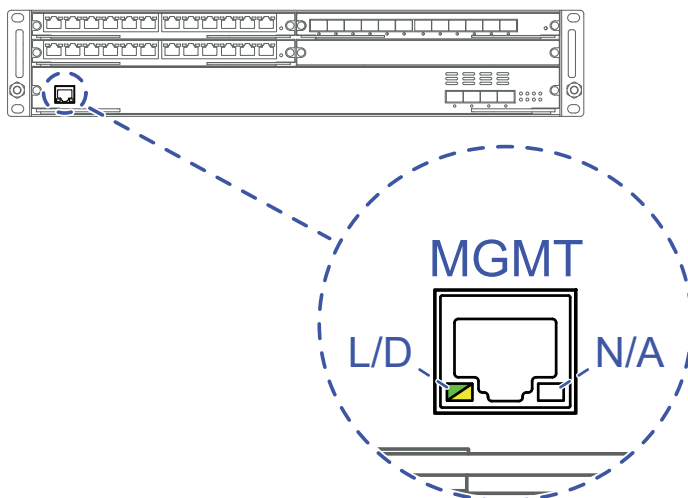

Figure 15: Management interface status: Location of the display elements on the MGMT port (front side of the device)

Note: In the present hardware version, the right side port LED of the MGMT port is without function (N/A). The port status of the MGMT port is displayed via the left side port LED.

LED	Display	Color	Activity	Meaning
L/D	Link state/data traffic	—	none	Device detects an invalid or missing link
		green	lights up	Device detects a valid link
			flashes 1 time a period	Port is switched to stand-by
			flashes 3 times a period	Port is switched off
		yellow	flashing alternately	Device is transmitting and/or receiving data
flashes 1 time a period	Device detects at least one unauthorized MAC address (Port Security Violation) and sends a trap.			

1.6.5 Media module status

■ D4K-12TP-RJ45

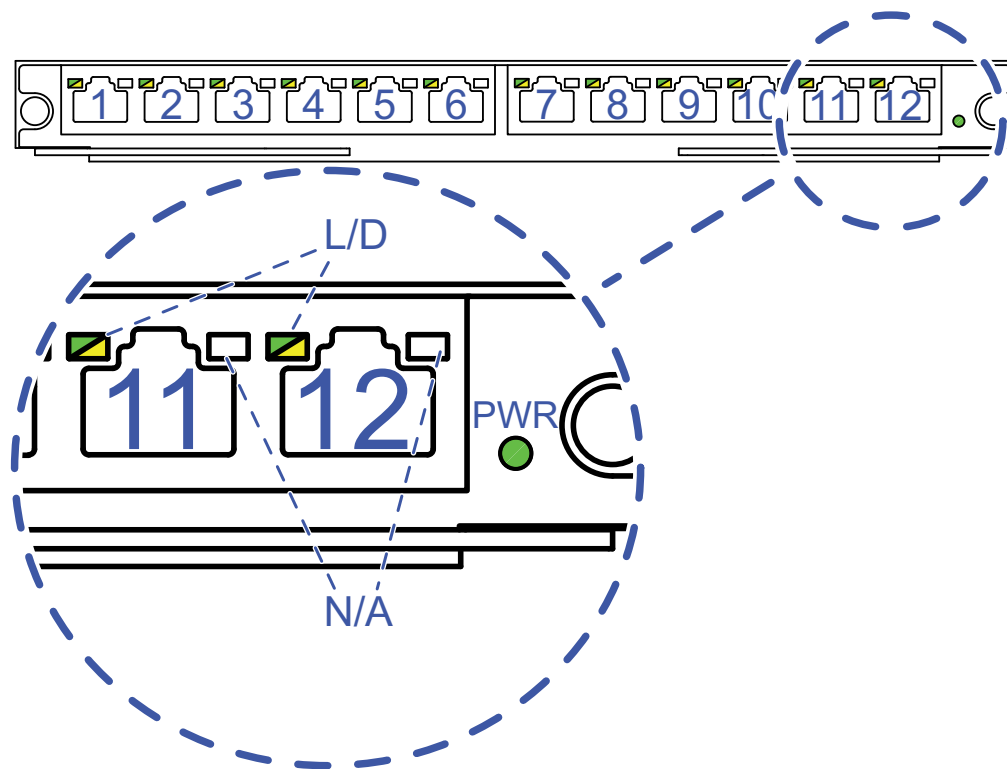

Figure 16: Media module status: Location of the display elements on the module

Note: In the present hardware version, the right side port LED of each RJ45 port is without function (N/A). The port status is displayed via the left side port LED.

LED	Display	Color	Activity	Meaning
PWR	Supply voltage	—	none	Media module is inoperative
		green	lights up	Voltage supply to the media module is on
L/D	Link state/ data traffic	—	none	Device detects an invalid or missing link
		green	lights up	Device detects a valid link
			flashes 1 time a period	Port is switched to stand-by
			flashes 3 times a period	Port is switched off
		yellow	flashing	Device is transmitting and/or receiving data
			flashes 1 time a period	Device detects at least one unauthorized MAC address (Port Security Violation)
			flashes 3 times a period	The device deactivates the relevant port (auto-deactivation).

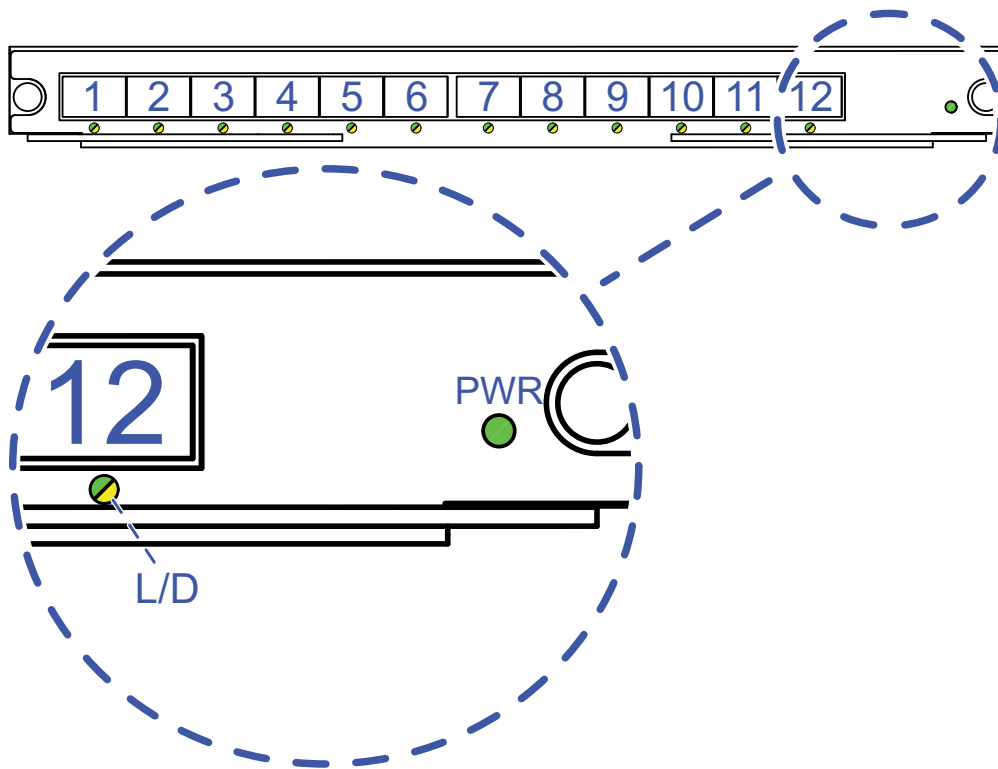

Figure 17: Media module status: Location of the display elements on the module

LED	Display	Color	Activity	Meaning
PWR	Supply voltage	—	none	Media module is inoperative
		green	lights up	Voltage supply to the media module is on
L/D	Link state/ data traffic	—	none	Device detects an invalid or missing link
		green	lights up	Device detects a valid link
			flashes 1 time a period	Port is switched to stand-by
			flashes 3 times a period	Port is switched off
		yellow	lights up	Device detects a non-supported SFP transceiver or a non-supported data rate
			flashing	Device is transmitting and/or receiving data
			flashes 1 time a period	Device detects at least one unauthorized MAC address (Port Security Violation)
			flashes 3 times a period	The device deactivates the relevant port (auto-deactivation).

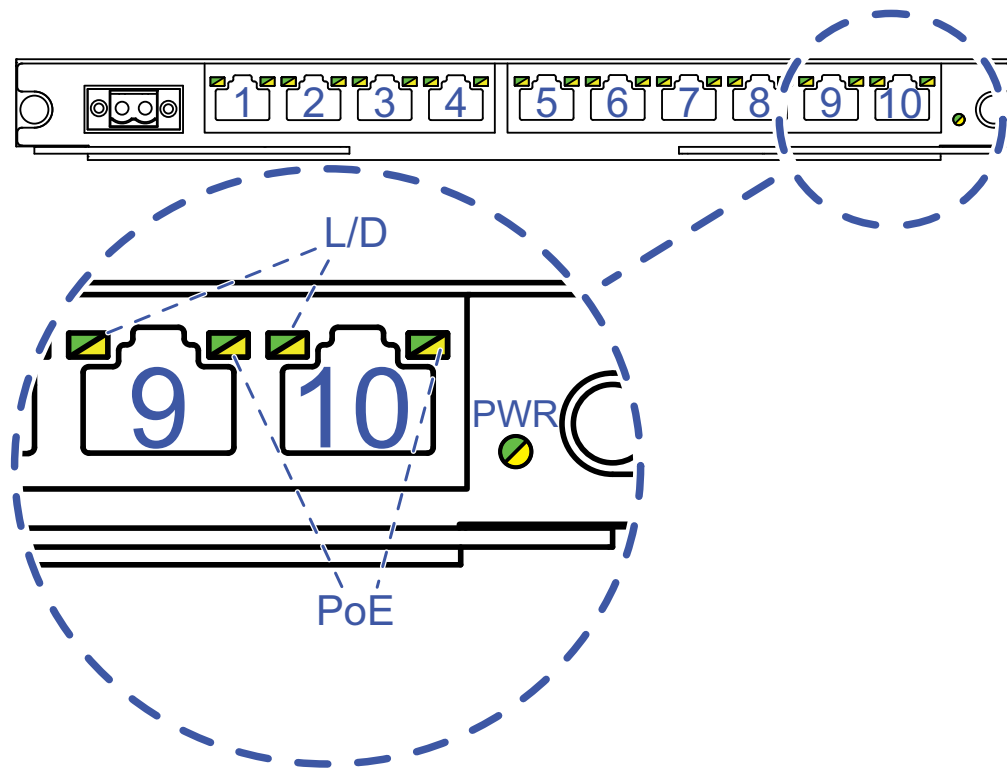

Figure 18: Media module status: Location of the display elements on the module

LED	Display	Color	Activity	Meaning
PWR	Supply voltage	—	none	Media module is inoperative
		green	lights up	Voltage supply to the media module is on The external supply voltage for PoE is connected
		yellow	lights up	There is no external supply voltage for PoE or it is too low
L/D	Link state/ data traffic	—	none	Device detects an invalid or missing link
		green	lights up	Device detects a valid link
			flashes 1 time a period	Port is switched to stand-by
			flashes 3 times a period	Port is switched off
		yellow	flashing	Device is transmitting and/or receiving data
			flashes 1 time a period	Device detects at least one unauthorized MAC address (Port Security Violation)
			flashes 3 times a period	The device deactivates the relevant port (auto-deactivation).
PoE	PoE status	green	lights up	Powered device is supplied with PoE voltage.
		yellow	flashes 1 time a period	Output budget has been exceeded Device has detected a connected powered device
			flashes 3 times a period	PoE administrator status deactivated

1.7 Management interfaces

1.7.1 V.24 interface (external management)

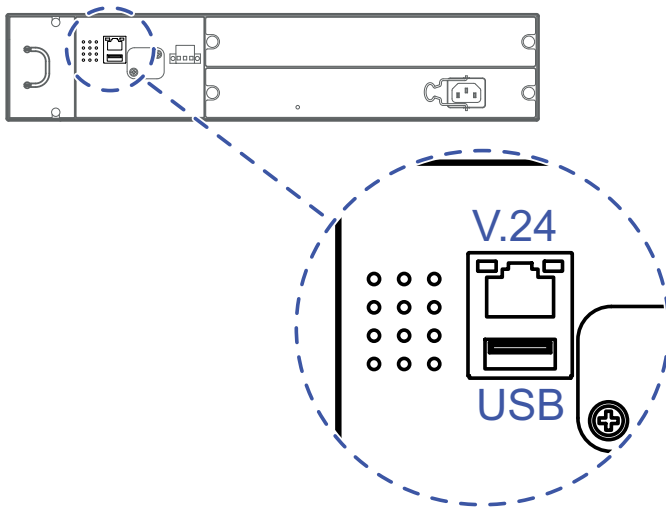

Figure 19: V.24 interface: Location on the device (rear side of the device)

A serial interface is provided on the RJ45 socket (V.24 interface) for the local connection of an external management station (VT100 terminal or PC with corresponding terminal emulation). This enables you to set up a connection to the Command Line Interface CLI and to the system monitor.

VT100 terminal settings

Speed	9600 Baud
Data	8 bit
Stopbit	1 bit
Handshake	off
Parity	none

The socket housing is electrically connected to the front panel of the device. The V.24 interface is electrically insulated from the supply voltage.

Figure	Pin assignment	Function
	1	—
	2	—
	3	TxD
	4	GND
	5	—
	6	RxD
	7	—
	8	—

Table 4: Pin assignment of the V.24 interface

1.7.2 USB interface

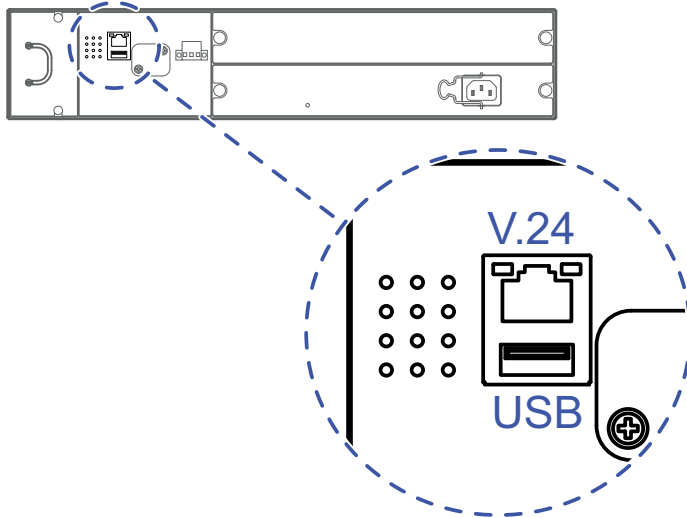

Figure 20: USB interface: Location on the device (rear side of the device)

The USB interface allows you to connect the AutoConfiguration Adapter ACA22 storage medium. This is used for saving/loading the configuration data and diagnostic information, and for loading the software.

See “Accessories” on page 90.

On the front and rear side of the device there are LEDs that inform you about the status of the interface.

The USB interface has the following properties:

- ▶ Supplies current of max. 500 mA
- ▶ Voltage not potential-separated
- ▶ Connectors: type A
- ▶ Supports the USB master mode
- ▶ Supports USB 2.0

Figure	Pin	Function
	1	VCC (VBus)
	2	- Data
	3	+ Data
	4	Ground (GND)

Table 5: Pin assignment of the USB interface

1.7.3 SD card interface

Prerequisite:

Only use Hirschmann SD cards.

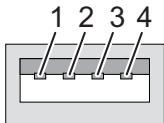
See “Accessories” on page 90.

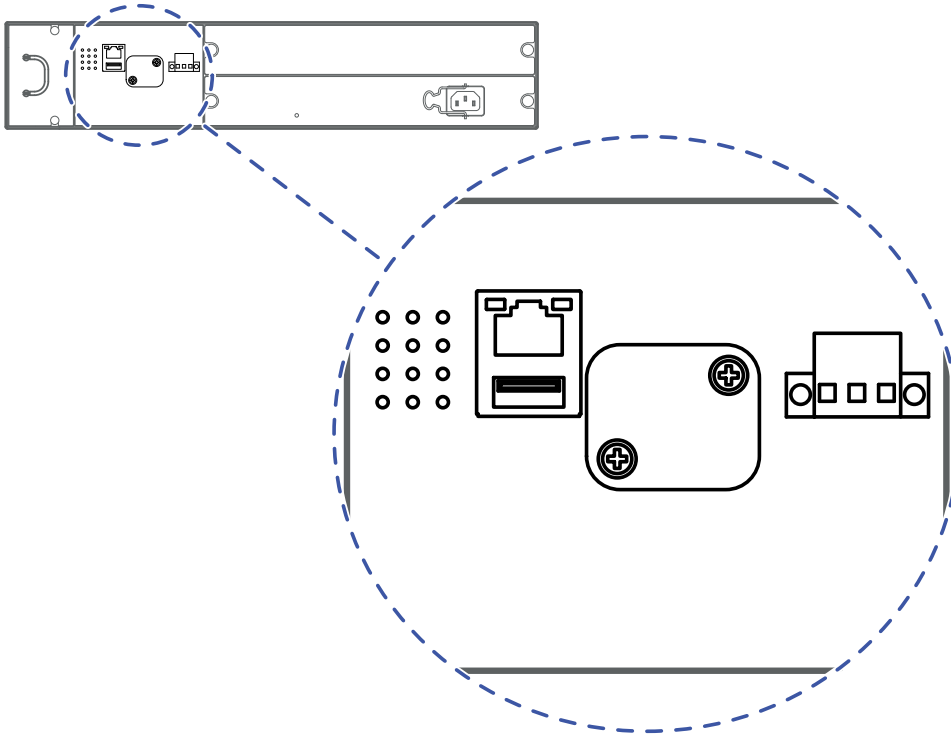

Figure 21: SD card interface: Location on the device (rear side of the device)

The SD card interface allows you to connect the AutoConfiguration Adapter ACA31 storage medium. This is used for saving/loading the configuration data and diagnostic information, and for loading the software.

On the front and rear side of the device there are LEDs that inform you about the status of the interface.

2 Installation

The devices have been developed for practical application in a harsh industrial environment.

On delivery, the device is ready for operation.

Perform the following steps to install and configure the device:

- ▶ [Checking the package contents](#)
- ▶ [Installing the SD card \(optional\)](#)
- ▶ [Installing a cover panel \(optional\)](#)
- ▶ [Installing a power supply module](#)
- ▶ [Installing a media module \(optional\)](#)
- ▶ [Mounting the fan module](#)
- ▶ [Installing and grounding the device](#)
- ▶ [Wiring and mounting the signal contact \(optional\)](#)
- ▶ [Connecting the supply voltage](#)
- ▶ [Installing an SFP transceiver \(optional\)](#)
- ▶ [Operating the device](#)
- ▶ [Connecting data cables](#)

2.1 Checking the package contents

- Check whether the package includes all items named in the section [“Scope of delivery” on page 88](#).
- Check the individual parts for transport damage.

2.2 Installing the SD card (optional)

Prerequisite:

Only use the AutoConfiguration Adapter ACA31 storage medium.

See [“Accessories” on page 90](#).

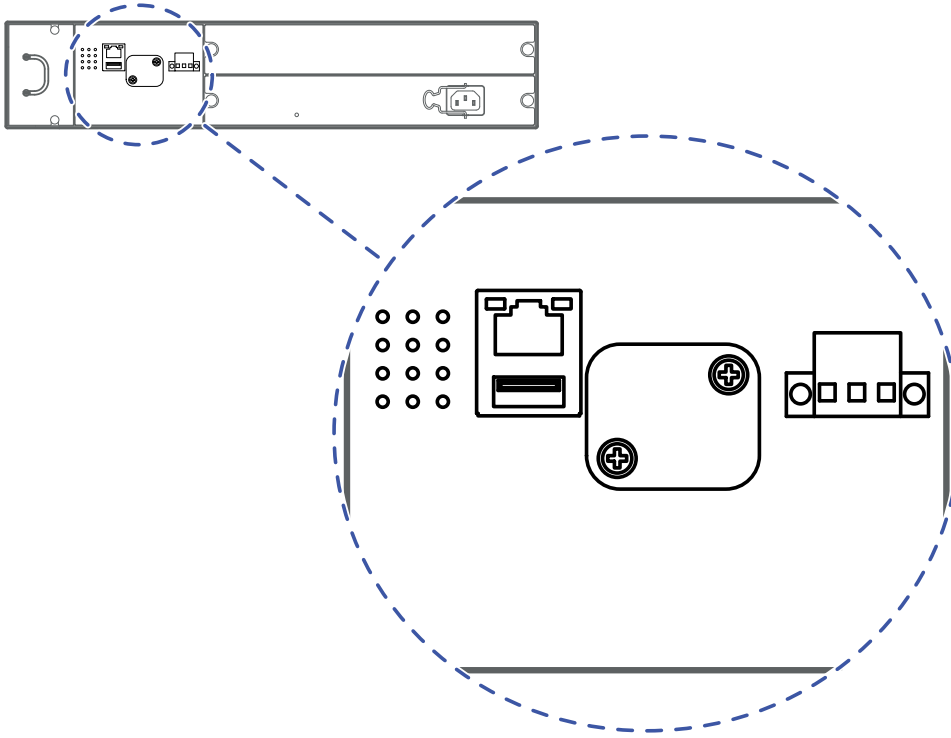

Figure 22: Inserting an SD card: Location on the device (rear side of the device)

Proceed as follows:

- Deactivate the write protection on the SD card by pushing the write-protect lock away from the middle of the card.
- Unscrew the top right side screw of the SD card slot cover.
- Slide the cover clockwise using the unscrewed screw. The SD card slot is now accessible.

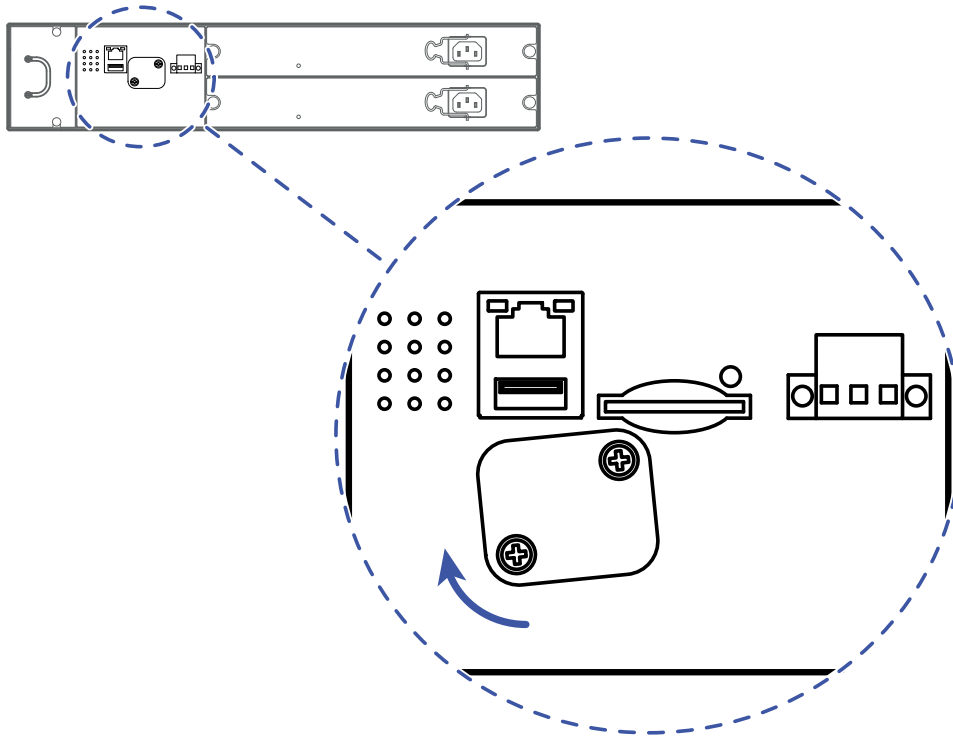

Figure 23: Inserting an SD card: Opening the SD card slot cover (rear side of the device)

Proceed as follows:

- Push the SD card into the slot with the beveled corner on the right side.
- Slide the cover counterclockwise back into its original location using the unscrewed screw. Secure the SD card by screwing the cover.

2.3 Installing a cover panel (optional)

Prerequisite:

To comply with the EMC requirements, seal unused open slots with a cover panel; you obtain cover panels as an accessory.

See [“Order numbers” on page 89](#).

Proceed as follows:

- Place the matching cover panel over the power supply module slot or media module slot of the device.
- Fasten the cover panel to the device by tightening the 2 screws.
You find the prescribed tightening torque in chapter: [“General data” on page 72](#)

2.4 Installing a power supply module

Hirschmann supplies the power supply modules in a ready-to-operate state. The power supply modules are hot-swappable.

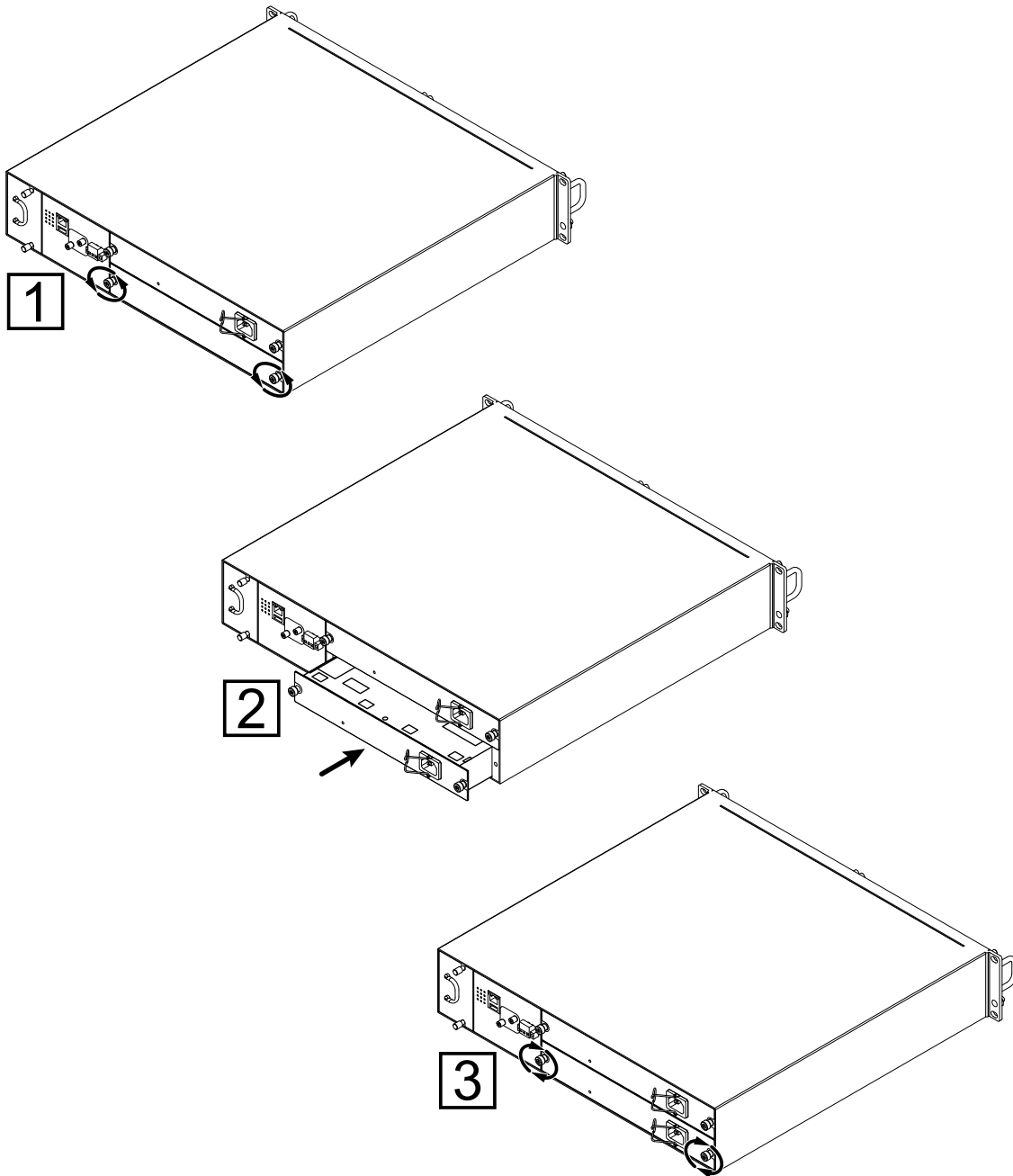

Figure 24: Mounting a PSU module: Installation (rear side of the device)

Proceed as follows:

- Remove the cover panel (if mounted) from the power supply module slot on the device (1).
- Insert the power supply module straight into the slot (2).
- Fasten the power supply module to the device by tightening the 2 screws (3).

You find the prescribed tightening torque in chapter:

[“General data” on page 72](#)

2.5 Installing a media module (optional)

Hirschmann supplies the media modules in a ready-to-operate state. By using a media module, you obtain up to 12 additional Fast and/or Gigabit Ethernet ports.

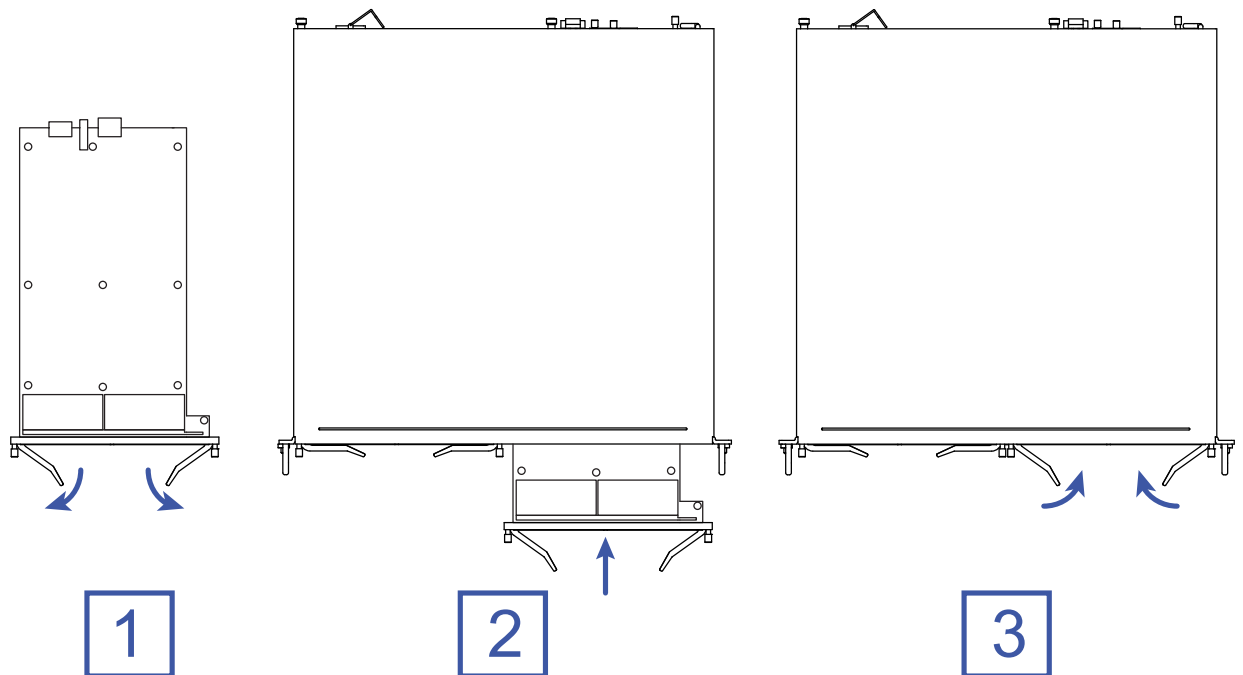

Figure 25: Mounting a media module: Installation sequence (front side of the device)

Proceed as follows:

- Remove the cover panel from the media module slot on the basic device.
- Open the locking mechanism of the media module by pressing the locking levers outwards (1).
- Insert the media module straight into the media module slot (2).
- Lock the media module in place by pressing the locking levers inwards (3).
- Fasten the media module with the screws in the front panel of the basic device.

You find the prescribed tightening torque in chapter:

[“General data” on page 72](#)

Note: The media module D4K-10TP-PoE is not hot-plugable. When mounting media modules of type D4K-10TP-PoE, the power supply of the basic device and the PoE power supply must be switched off.

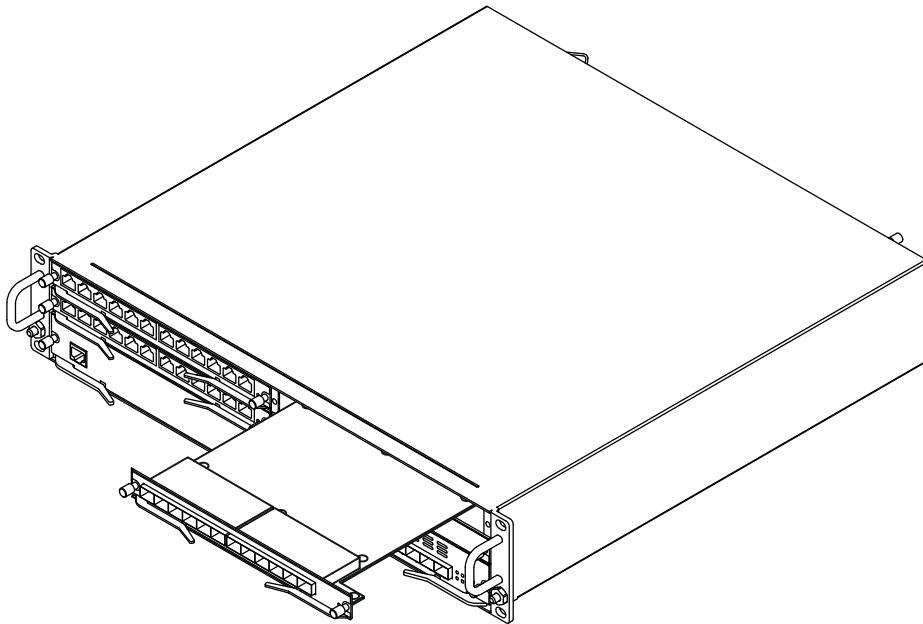

Figure 26: Mounting a media module: Installation (front side of the device)

2.6 Mounting the fan module



CAUTION

RISK OF INJURY FROM SPINNING FANS

After removing the fan module during active operation, the individual fans continue to spin for a few seconds. Do not touch rotating fan blades. Do not insert objects into rotating fan blades.

Failure to follow these instructions can result in injury or equipment damage.

NOTICE

OVERHEATING OF THE DEVICE

The device may overheat if the fan module fails or is removed. Switch off the device or replace the fan module within 2 minutes, otherwise failures or damage to the device may occur.

Failure to follow these instructions can result in equipment damage.

Hirschmann supplies fan modules in a ready-to-operate state. You have the option to replace fan modules while the device is operating.

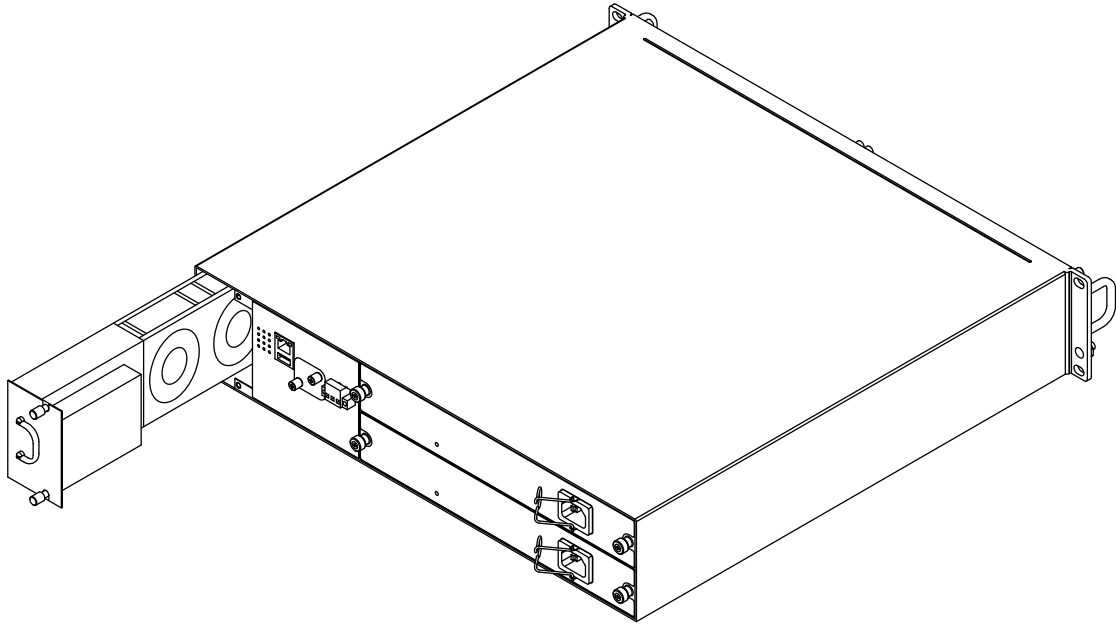

Figure 27: Mounting a fan module: Installation (rear side of the device)

Proceed as follows:

- Unscrew the 2 screws of the fan module on the device.
- Pull the fan module out of the slot using the foldable mounting handle.
- Insert the new fan module straight into the slot.
- Fasten the fan module to the device by tightening the 2 screws.
You find the prescribed tightening torque in chapter:
[“General data” on page 72](#)

2.7 Installing and grounding the device

■ Mounting in a switch cabinet



WARNING

ELECTRIC SHOCK

Exclusively install this device in a switch cabinet or in a restricted access location according to EN 62368-1, to which maintenance staff have exclusive access.

Failure to follow these instructions can result in death, serious injury, or equipment damage.



CAUTION

OVERHEATING OF THE DEVICE

Verify that all ventilation slots are clear when installing the device. Avoid touching the device while it is operating.

Failure to follow these instructions can result in minor injury or equipment damage.

Prerequisites:

- ▶ Install the device in the 19" switch cabinet using sliding or mounting rails.
This provides a more stable position of your device in environments subject to vibration.
For more information on sliding/mounting rails and how to install them, please contact your switch cabinet manufacturer.
- ▶ The devices are designed to be mounted in a 19" switch cabinet. In the delivery state, there are 2 pre-mounted mounting brackets on the sides of the device.
- ▶ Ensure adequate ventilation. If necessary, install an additional fan in the switch cabinet to prevent the device from overheating.
- ▶ Measure the depth of the 19" cabinet so that all the lines to be connected can be fed in easily.

Proceed as follows:

- Assemble the sliding or mounting rails in the 19" switch cabinet as specified by the manufacturer.
- Position the device on the rails in the switch cabinet.
- Fasten the device in the switch cabinet by screwing it in with the mounting brackets.

- Grounding the device
The device has 2 protective ground connections.

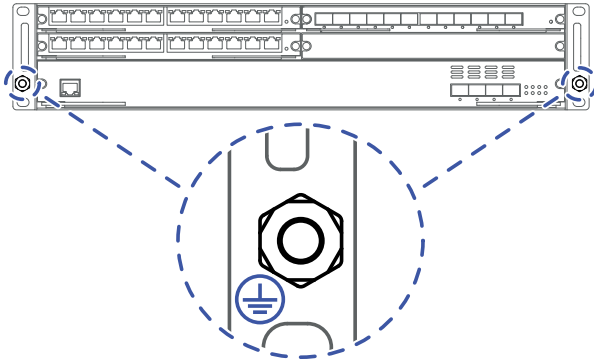

Figure 28: Grounding: Location of ground connections on the device (front side of the device)

The device is grounded via one of the two grounding nuts and in addition via the power supply connection (built-in non-heating device plug C14 according to IEC 60320-1).

Proceed as follows:

- Ground the device via one grounding nut.
You find the prescribed tightening torque in chapter:
[“General data” on page 72](#)

2.8 Wiring and mounting the signal contact (optional)

WARNING

ELECTRIC SHOCK

Start connecting electrical wires only if all safety requirements listed in chapter “[General safety instructions](#)” are fulfilled.

Failure to follow these instructions can result in death, serious injury, or equipment damage.

WARNING

ELECTRIC SHOCK

Never insert sharp objects (small screwdrivers, wires, or similar items) into the connection terminals for the signal lines, and do not touch the terminals.

Failure to follow these instructions can result in death, serious injury, or equipment damage.

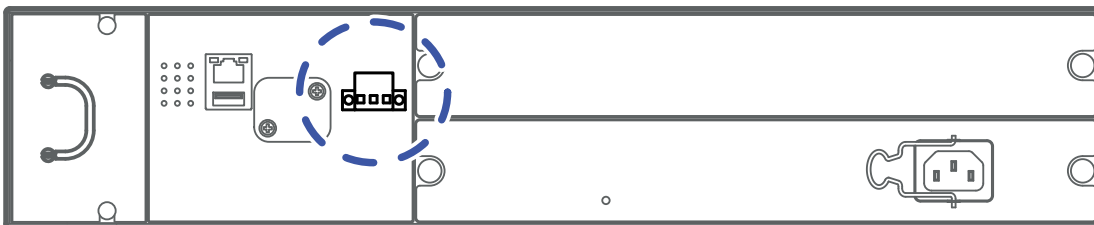
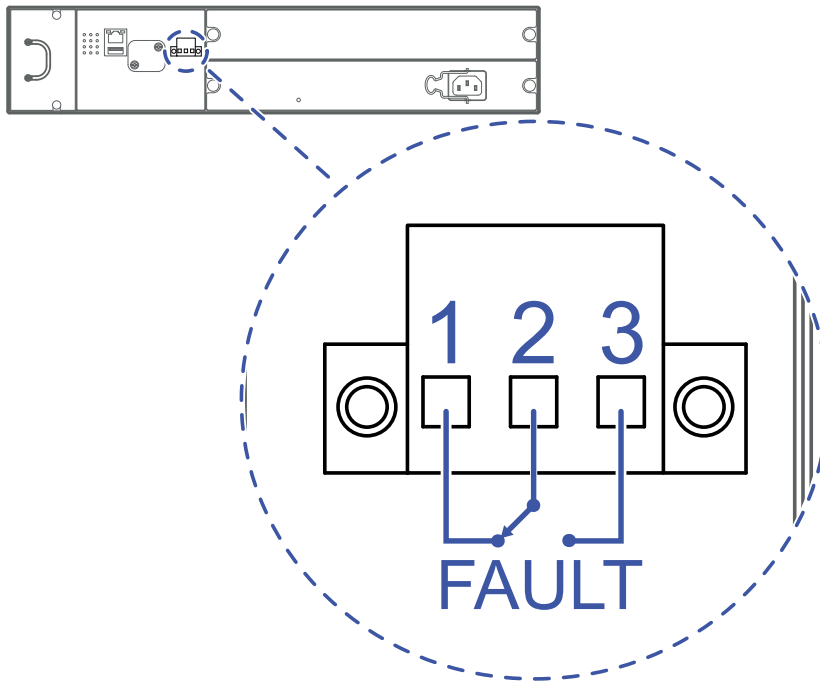

Figure 29: Signal contact: 3-pin terminal block with screw lock; position on the device (rear side of the device)



Signal contact

1	NC	Normally closed contact
2	CO	Changeover contact
3	NO	Normally open contact

Proceed as follows:

- Connect the signal contact lines with the terminal block connections.
- Fasten the wires in the terminal block by tightening the terminal screws.
- Mount the terminal block on the device using screws.

You find the prescribed tightening torque in chapter:

[“General data” on page 72](#)

2.9 Connecting the supply voltage



WARNING

ELECTRIC SHOCK

Start connecting electrical wires only if all safety requirements listed in chapter “[General safety instructions](#)” are fulfilled.

Failure to follow these instructions can result in death, serious injury, or equipment damage.



WARNING

ELECTRIC SHOCK

Never insert pointed objects (narrow screwdrivers, wires, etc.) into the device or into the connection terminals for electric conductors.

Do not touch the connection terminals.

Failure to follow these instructions can result in death, serious injury, or equipment damage.



WARNING

ELECTRIC SHOCK

Connect only a supply voltage that corresponds to the type plate of your device.

Failure to follow these instructions can result in death, serious injury, or equipment damage.

2.9.1 Power supply modules

You have the option of supplying the supply voltage redundantly, without load distribution.

The supply voltage is electrically isolated from the casing.

Note: The supply voltage is connected to the device casing through protective elements exclusively.

Note: Seal unused PSU module slots with a cover panel. You obtain additional cover panels as accessories.

See “Accessories” on page 90.

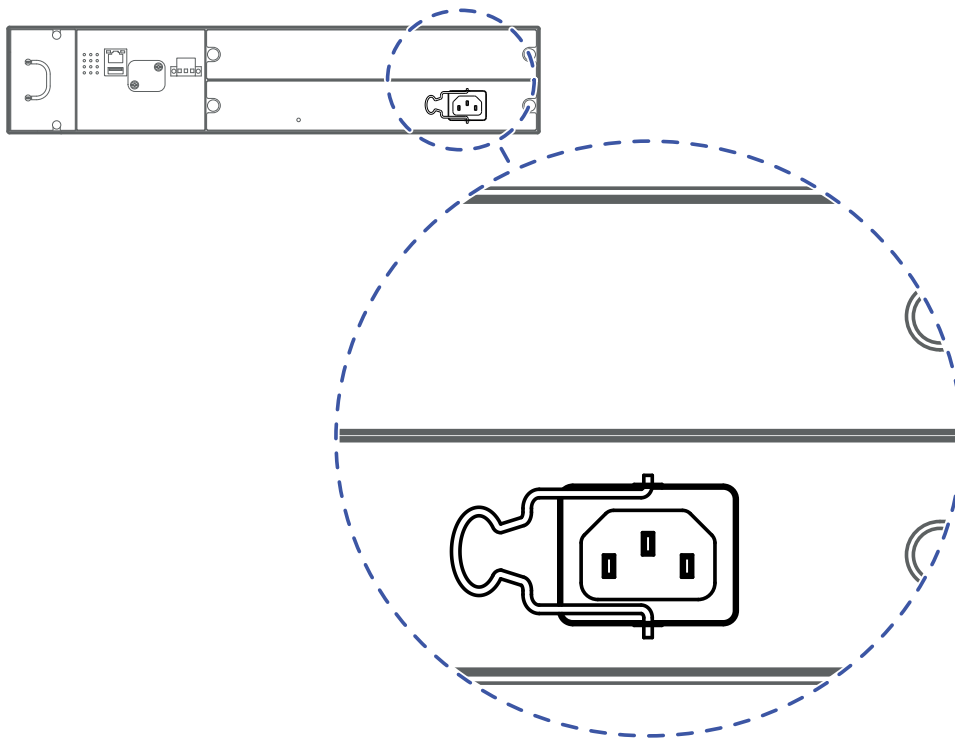

Figure 30: Connecting the power supply: PSU modules (rear side of device)

For **every** supply voltage to be connected, perform the following steps:

- On the rear side of the device, plug a non-heating device cable with C13 coupling according to IEC 60320-1 into the power supply connection (built-in C14 plug) of the PSU module.
- Secure the coupling against falling out by sliding the safety catch of the built-in non-heating appliance plug over the coupling.

Type of the voltages that can be connected	Specification of the supply voltage	Pin assignment
AC voltage	Rated voltage range 110 V AC ... 240 V AC, 50 Hz ... 60 Hz	L Outer conductor N Neutral conductor ⊕ Protective conductor

Table 6: Type and specification of the supply voltage, connections

2.9.2 Media module D4K-10TP-PoE

Details about the power supply of the media module can be found in chapter “Supply voltage” on page 73.

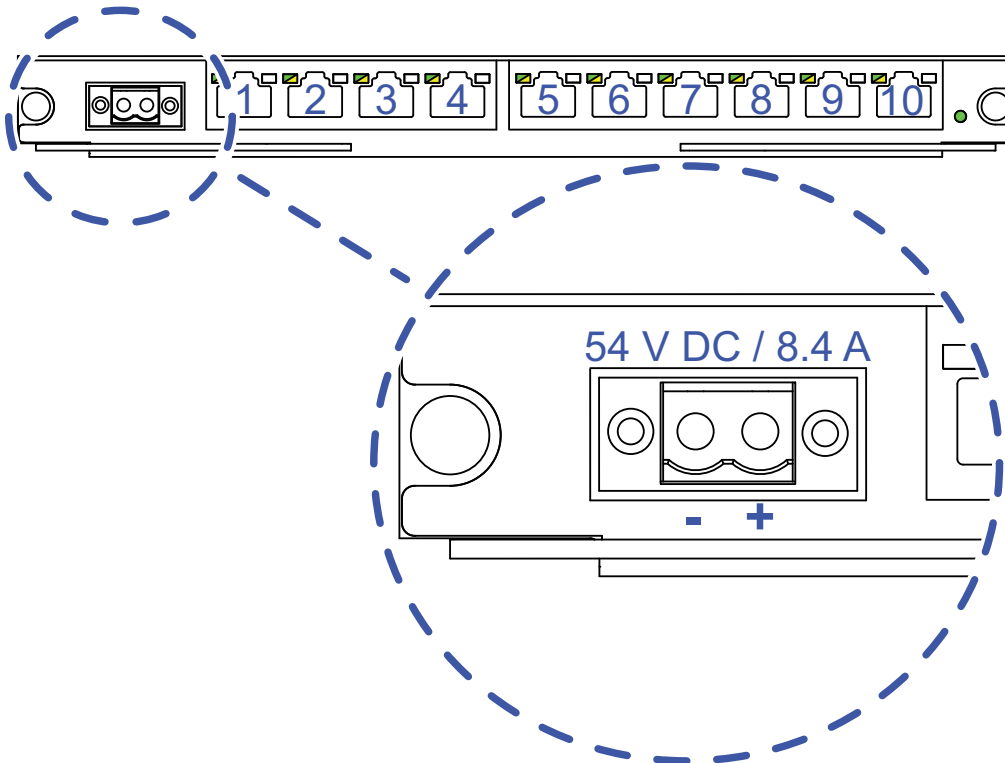

Figure 31: Power supply: Terminal block on the media module

To supply the media module D4K-10TP-PoE with PoE voltage, proceed as follows:

- Mount the media module in the basic device.
- Remove the terminal connector from the device.
- Connect the input signal lines to the terminal block.
For details see [figure 31](#).
- Fasten the wires in the terminal block by tightening the terminal screws.
- Mount the terminal block on the device using screws.
- By connecting the PoE supply voltage, you put the PoE functionality into operation.

Note: Exclusively pull and plug the terminal block of the PoE power supply on the D4K-10TP-PoE media module in a voltage-free state. The media module D4K-10TP-PoE is not hot-pluggable.

Note: The media module D4K-10TP-PoE offers only basic switching functionality when mounted without additional PoE supply voltage.

Note: Exclusively connect voltage sources >50 V DC to the media module D4K-10TP-PoE. Otherwise no PoE power supply via the ports is possible.

2.10 Installing an SFP transceiver (optional)

Prerequisites:

Exclusively use Hirschmann SFP transceivers.

See [“Accessories” on page 90](#).

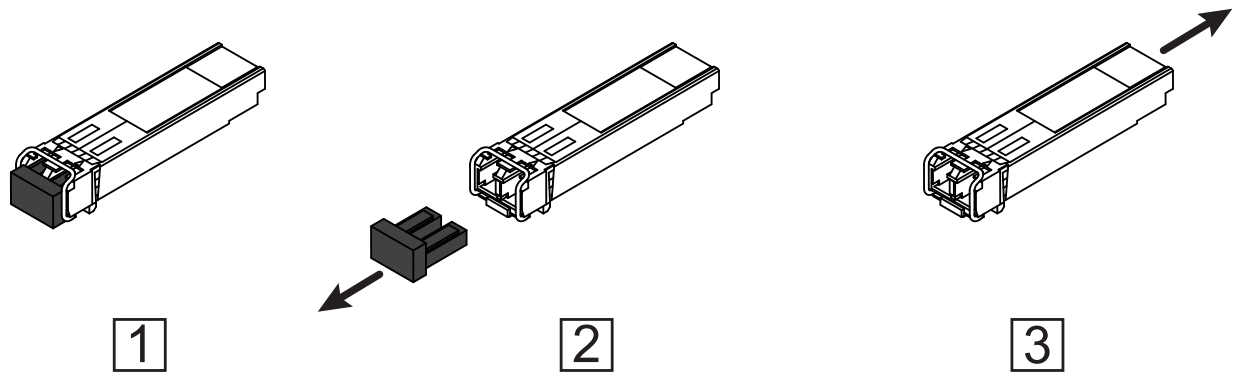

Figure 32: Installing SFP transceivers: Installation sequence

Perform the following work steps:

- Take the SFP transceiver out of the transport packaging (1).
- Remove the protection cap from the SFP transceiver (2).
- Push the SFP transceiver with the lock closed into the slot until it latches in (3).

2.11 Operating the device

Proceed as follows:

- Enable the supply voltage.

2.12 Connecting data cables

Note the following general recommendations for data cable connections in environments with high electrical interference levels:

- Keep the length of the data cables as short as possible.
- Use optical data cables for the data transmission between the buildings.
- When using copper cables, provide a sufficient separation between the power supply cables and the data cables. Ideally, install the cables in separate cable channels.
- Verify that power supply cables and data cables do not run parallel over longer distances. To reduce inductive coupling, verify that the power supply cables and data cables cross at a 90° angle.
- Use shielded data cables for gigabit transmission via copper cables, for example SF/UTP cables according to ISO/IEC 11801. Exclusively use shielded data cables to meet EMC requirements according to EN 50121-4 and marine applications.
- Connect the data cables according to your requirements.
[See “Ethernet ports” on page 29.](#)

3 Making basic settings

Note: 2 or more devices configured with the same IP address can cause unpredictable operation of your network.

Install and maintain a process that assigns a unique IP address to every device in the network.

The IP parameters must be entered when the device is installed for the first time. The device provides the following options for configuring the IP addresses:

- ▶ V.24 interface (Command Line Interface)
- ▶ BOOTP
- ▶ DHCP
- ▶ DHCP Option 82
- ▶ AutoConfiguration Adapter
- ▶ Input via the HiView or Industrial HiVision application. You find further information about the applications HiView or Industrial HiVision on the Internet at the Hirschmann product pages:

HiView

<http://www.hirschmann.com/en/QR/INET-HiView>

Industrial HiVision

<http://www.hirschmann.com/en/QR/INET-Industrial-HiVision>

■ Default settings

- ▶ IP address: The device looks for the IP address using DHCP
- ▶ Password for management:
 - Login: user; password: public (read only)
 - Login: admin; password: private (read and write)
- ▶ Parameters that can be set via the management are set to pre-defined values in accordance with the MIB
- ▶ V.24 data rate: 9600 Baud
- ▶ Ring redundancy: disabled
- ▶ Ethernet ports: link status is not evaluated (signal contact)
- ▶ Basic device:
 - Optical 10 Gbit/s ports: 10 Gbit/s full duplex
 - Autonegotiation deactivated.
- ▶ Media module D4K-12TP-RJ45:
 - 10/100/1000 Mbit/s ports: 10/100/1000 Mbit/s full duplex
 - Autonegotiation activated.
- ▶ Media module D4K-12SFP:
 - Optical 100/1000 Mbit/s ports: 100/1000 Mbit/s full duplex
 - Autonegotiation exclusively activated for 1000 Mbit/s.
- ▶ Out-of-band management port:
 - Default IP address: 192.168.1.1 / 255.255.255.0

■ First login (Password change)

To help prevent undesired access to the device, it is imperative that you change the default password during initial setup.

Perform the following steps:

- Open the Graphical User Interface, the Command Line Interface, or HiView the first time you log on to the device.
- Log on to the device with the default password “private”. The device prompts you to type in a new password.
- Type in your new password.
To help increase security, choose a password that contains at least 8 characters which includes upper-case characters, lower-case characters, numerical digits, and special characters.
- When you log on to the device with the Command Line Interface, then the device prompts you to confirm your new password.
- Log on to the device again with your new password.

Note: If you lost your password, then use the System Monitor to reset the password.

For further information see:

<https://hirschmann-support.belden.com/en/kb/required-password-change-new-procedure-for-first-time-login>

4 Monitoring the ambient air temperature

Operate the device below the specified maximum ambient air temperature exclusively.

See [“Climatic conditions during operation” on page 75.](#)

The ambient air temperature is the temperature of the air at a distance of 5 cm (2 in) from the device. It depends on the installation conditions of the device, for example the distance from other devices or other objects, and the output of neighboring devices.

5 Maintenance and service

- When designing this device, Hirschmann largely avoided using high-wear parts. The parts subject to wear and tear are dimensioned to last longer than the lifetime of the product when it is operated normally. Operate this device according to the specifications.
- Relays are subject to natural wear. This wear depends on the frequency of the switching operations. Check the resistance of the closed relay contacts and the switching function depending on the frequency of the switching operations.
- Internal fuses are triggered only in the case of a detected error in the device. In case of damage or malfunction of the device, turn off the supply voltage and return the device to the plant for inspection.
- Hirschmann is continually working on improving and developing their software. Check regularly whether there is an updated version of the software that provides you with additional benefits. You find information and software downloads on the Hirschmann product pages on the Internet (<http://www.hirschmann.com>).
- Depending on the degree of pollution in the operating environment, check at regular intervals that the ventilation slots in the device are not obstructed.

You find information on settling complaints on the Internet at <http://www.beldensolutions.com/en/Service/Repairs/index.phtml>.

6 Disassembly

6.1 De-installing a power supply module

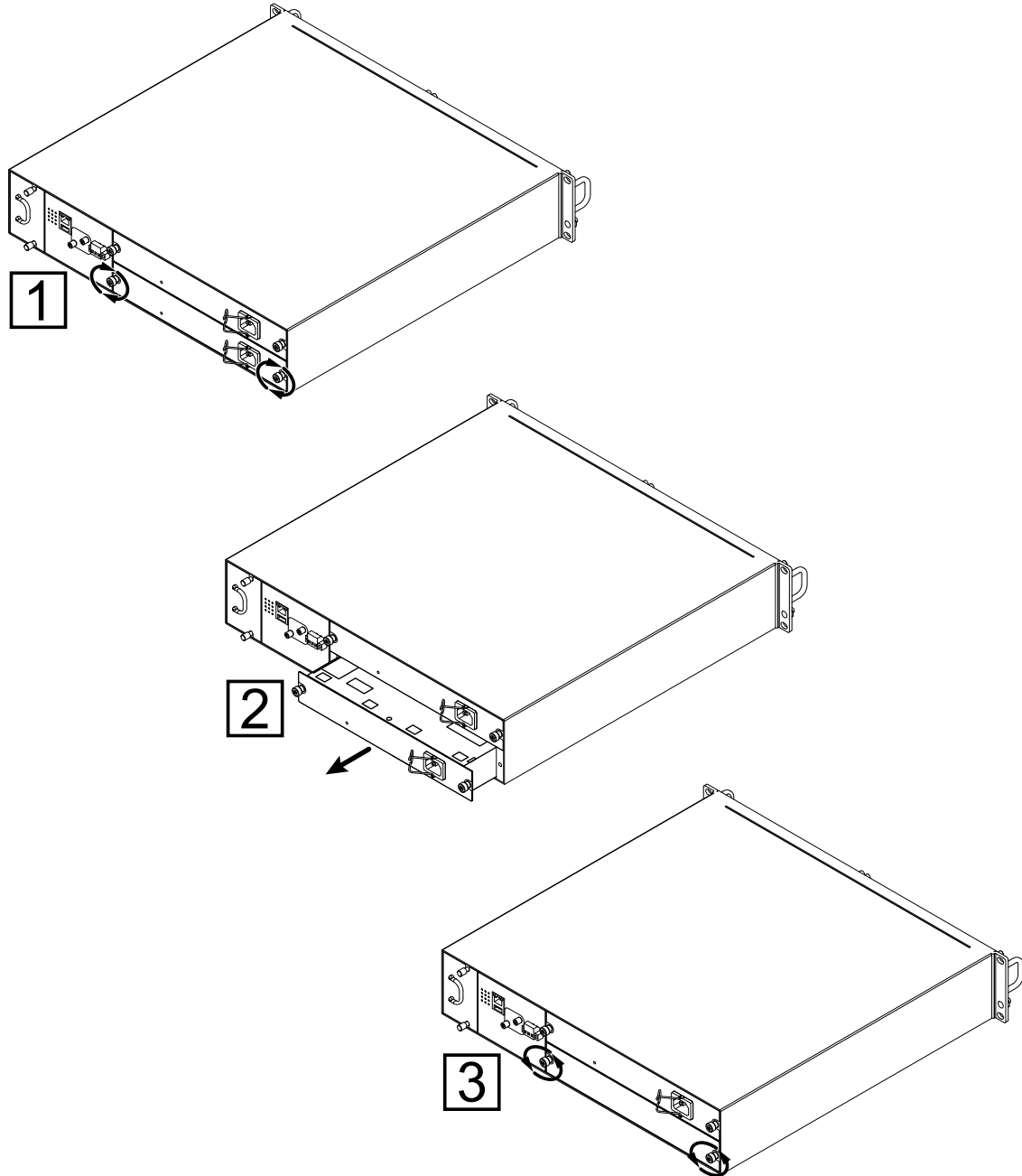

Figure 33: Removing a PSU module: Disassembly (rear side of the device)

Proceed as follows:

- Remove the screws on the front panel of the power supply module (1).
 - Pull the power supply module out of the slot (2).
 - Seal the power supply module slot on the basic device with a cover panel (3).
 - Fasten the cover panel using the 2 screws on the basic device.
- You find the prescribed tightening torque in chapter:
[“General data” on page 72](#)

6.2 Removing a fan module

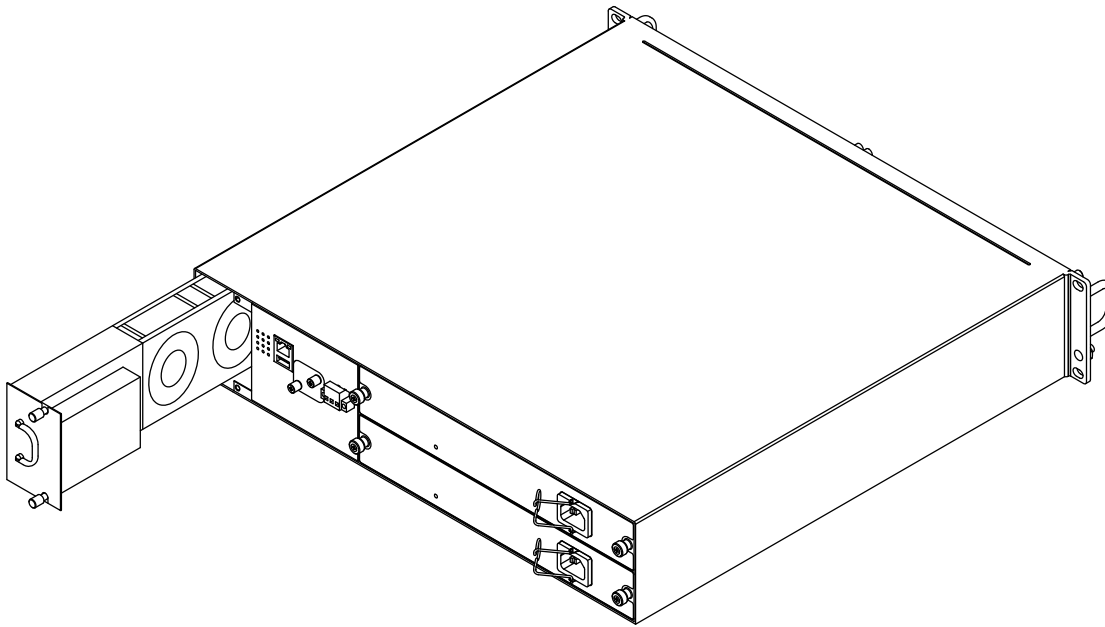

Figure 34: Removing a fan module: Disassembly (rear side of the device)

Proceed as follows:

- Unscrew the 2 screws of the fan module on the device.
- Pull the fan module out of the slot using the foldable mounting handle.

6.3 Removing a media module

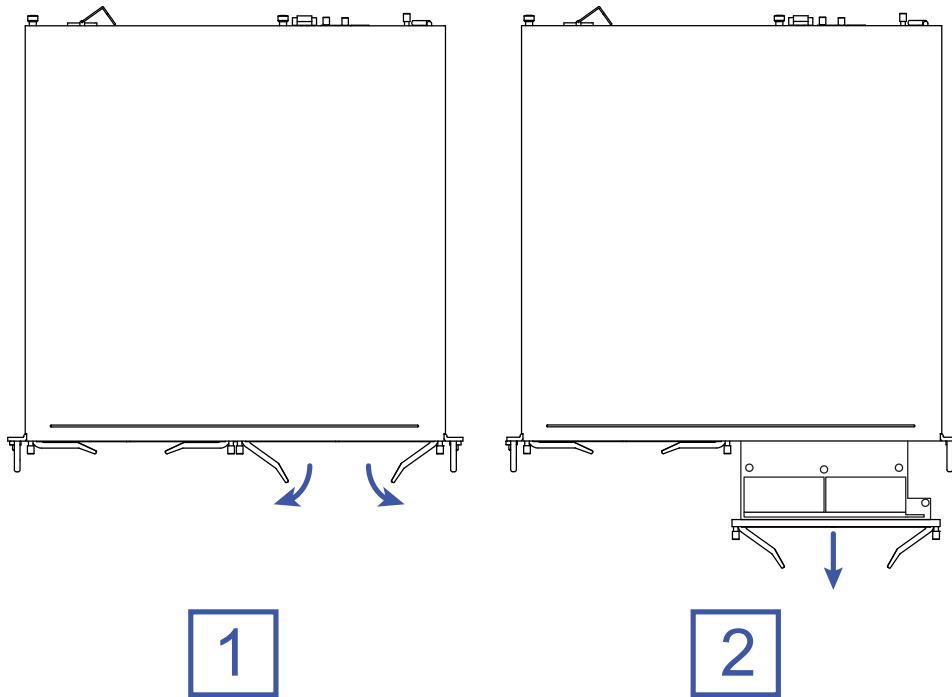

Figure 35: Removing a media module: Removal sequence (front side of the device)

Proceed as follows:

- Loosen the screws in the front panel of the media module.
- Open the locking mechanism of the media module by pressing the locking levers outwards (1).
- Pull the media module out of the slot (2).
- Close the media module slot on the basic device using a cover panel.
- Fasten the cover panel using the 2 screws on the basic device.

You find the prescribed tightening torque in chapter:
[“General data” on page 72](#)

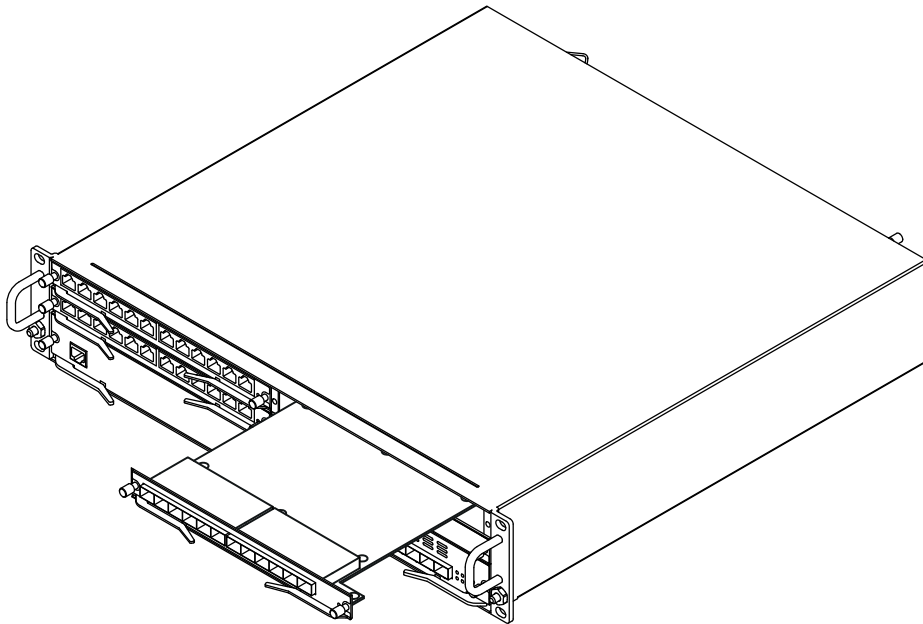

Figure 36: Removing a media module: Disassembly (front side of the device)

6.4 Removing an SFP transceiver (optional)

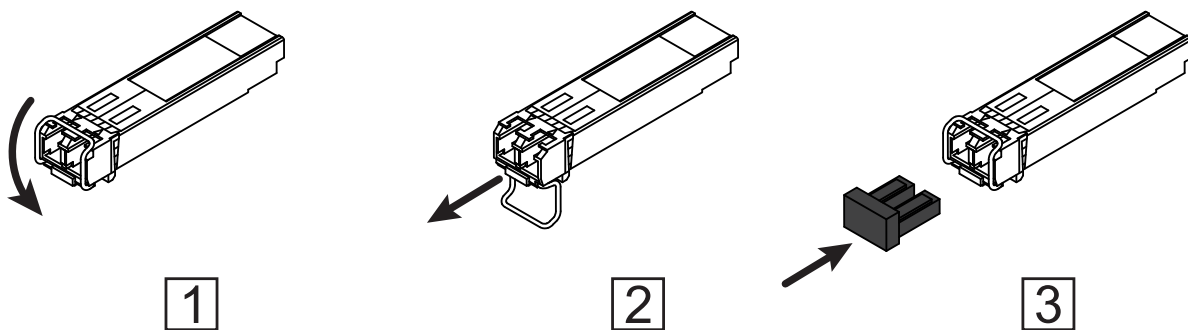

Figure 37: De-installing SFP transceivers: De-installation sequence

Perform the following work steps:

- Open the locking mechanism of the SFP transceiver (1).
- Pull the SFP transceiver out of the slot via the open locking mechanism (2).
- Close the SFP transceiver with the protection cap (3).

6.5 Removing the device



WARNING

ELECTRIC SHOCK

Disconnect the grounding only after disconnecting all other cables.

Failure to follow these instructions can result in death, serious injury, or equipment damage.

Proceed as follows:

- Disconnect the data cables.
- Disable the supply voltage.
- Unplug every non-heating device coupling to disconnect the device from the power supply.
- Disconnect the terminal blocks.
- Disconnect the grounding.
- To detach the device from its installation location, remove the screws from the mounting brackets on the device.

7 Technical data

7.1 General data

7.1.1 Basic device

Dimensions	See "Dimension drawings" on page 76.	
Weight	MACH4000	7.3 kg (16.09 lb)
	MACH4500	7.8 kg (17.2 lb)
Power supply	See "Power supply unit module" on page 77.	
Grounding the device	Tightening torque Protective grounding	0.5 Nm (4.4 lb-in)
Pollution degree		2
Protection classes	Laser protection	Class 1 in compliance with IEC 60825-1
	Degree of protection	IP20

7.1.2 Power supply unit module

Dimensions	See "Dimension drawings" on page 76.	
Weight		850 g (30 oz)
Mounting of the cover panel	Tightening torque	0.5 Nm (4.4 lb-in)
Mounting of the power supply modules	Tightening torque	0.5 Nm (4.4 lb-in)

7.1.3 Fan module

Dimensions	See "Dimension drawings" on page 76.	
Weight		750 g (26.46 oz)
Mounting a fan module	Tightening torque	0.5 Nm (4.4 lb-in)
Fan module	Noise emission	< 50 dB

7.1.4 Media modules

Dimensions	See "Dimension drawings" on page 76.	
Weight	D4K-12TP-RJ45	650 g (20.90 oz)
	D4K-12SFP	700 g (24.69 oz)
	D4K-10TP-PoE	700 g (24.69 oz)
Installing the media modules	Tightening torque	0.5 Nm (4.4 lb-in)
Mounting of the cover panel	Tightening torque	0.5 Nm (4.4 lb-in)
Protection classes	Laser protection	Class 1 in compliance with IEC 60825-1

7.2 Supply voltage

7.2.1 Power supply modules

Rated voltage	100 V AC ... 240 V AC, 50 Hz ... 60 Hz	
Voltage range incl. maximum tolerances	90 V AC ... 264 V AC, 47 Hz ... 63 Hz	
Connection type	Built-in non-heating device plug (C14 plug according to IEC 60320-1)	
	min. conductor diameter	0.75 mm ² (AWG18)
	max. conductor diameter	2.5 mm ² (AWG12)
Power loss buffer	> 30 ms at 100 V AC > 30 ms at 240 V AC	
Overload current protection on the device	Non-replaceable fuse	
Back-up fuse for each voltage input	Nominal rating:	6.3 A
	Characteristic:	slow blow
Peak inrush current	< 20 A (6 ms)	
Current integral I ² t	1.8 A ² s	
Crest factor	< 4	
Connection for protective ground	See "Grounding the device" on page 55.	

7.2.2 Media module D4K-10TP-PoE

Rated voltage	54 V DC	
Voltage range incl. maximum tolerances	52 V DC ... 57 V DC	
Connection type	2-pin terminal block	
	Tightening torque	0.5 Nm (4.4 lb-in)
	min. conductor diameter	1.5 mm ² (AWG14)
	max. conductor diameter	2.5 mm ² (AWG12)
Max. PoE power	Per media module:	300 W
	In total:	420 W
Overload current protection on the device	Non-replaceable fuse	
Back-up fuse for each voltage input	Nominal rating:	20 A
	Characteristic:	slow blow
Peak inrush current	40 A (0.5 ms)	
Current integral I ² t	1 A ² s	
Isolation requirements	2250 V DC to voltage input and casing ground	

7.3 Signal contact

Connection type	3-pin terminal block	
	Tightening torque	0.5 Nm (4.4 lb-in)
	min. conductor diameter	0.75 mm ² (AWG18)
	max. conductor diameter	1.3 mm ² (AWG16)
Nominal value	$I_{\max} = 2 \text{ A}$ at $U_{\max} = 230 \text{ V AC}$	
	$I_{\max} = 2 \text{ A}$ at $U_{\max} = 30 \text{ V DC}$	

7.4 Power consumption/power output

Name	Maximum power consumption	Maximum power output
Basic device incl. SFP transceivers + 1 PSU + Fan module		
MACH4000	80 W	273 Btu (IT)/h
MACH4500	120 W	410 Btu (IT)/h
Power supply unit (PSU)		
D4K-PSU-300W-HV	6 W	21 Btu (IT)/h
Fan module		
D4K-AIR	20 W	68 Btu (IT)/h
Media modules		
D4K-12TP-RJ45	15 W	51 Btu (IT)/h
D4K-12SFP incl. SFP transceiver	25 W	85 Btu (IT)/h
D4K-10TP-PoE	450 W	102 Btu (IT)/h

7.5 Climatic conditions during operation

Climatic conditions during operation	
Minimum clearance around the device	Top and bottom sides of device: 5 cm (2 in) Left and right device side: 2 cm (0.79 in)
Ambient air temperature ^a	0 °C ... +60 °C (+32 °F ... +140 °F) ^b
Humidity	10 % ... 95 % (non-condensing)
Air pressure	min. 795 hPa (+2000 m; +6562 ft) max. 1060 hPa (-400 m; -1312 ft)

Table 7: Climatic conditions during operation

- a. Temperature of the ambient air at a distance of 5 cm (2 in) from the device
- b. Hirschmann recommends to use SFP transceivers with "EEC" extension.

7.6 Climatic conditions during storage

Climatic conditions during storage	
Ambient temperature	-40 °C ... +70 °C (-40 °F ... +158 °F)
Humidity	5 % ... 95 % (non-condensing)
Air pressure	min. 795 hPa (+2000 m; +6562 ft) max. 1060 hPa (-400 m; -1312 ft)

Table 8: Climatic conditions during storage

7.7 Dimension drawings

7.7.1 Basic device

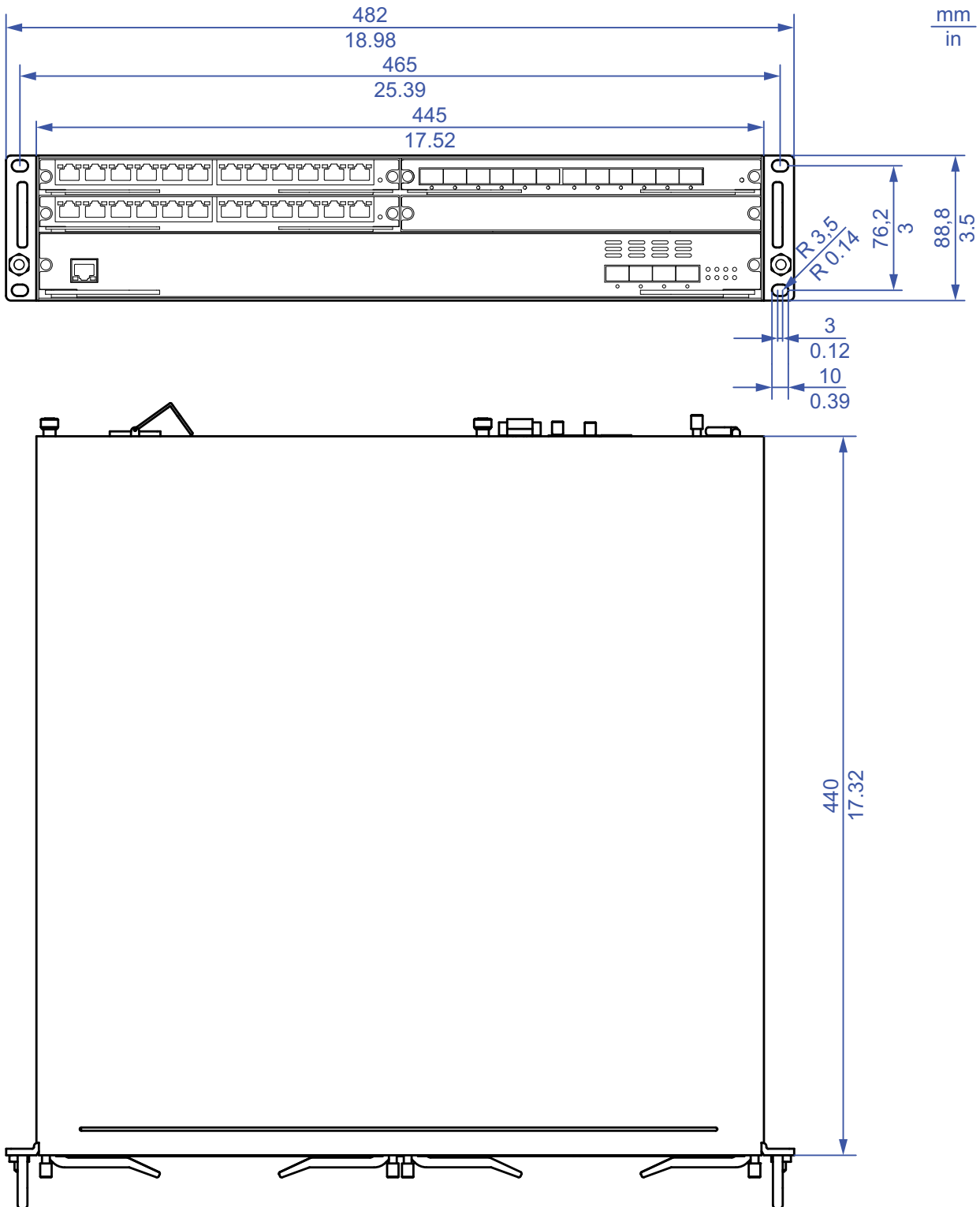

Figure 38: Dimension drawings: basic device

7.7.2 Power supply unit module

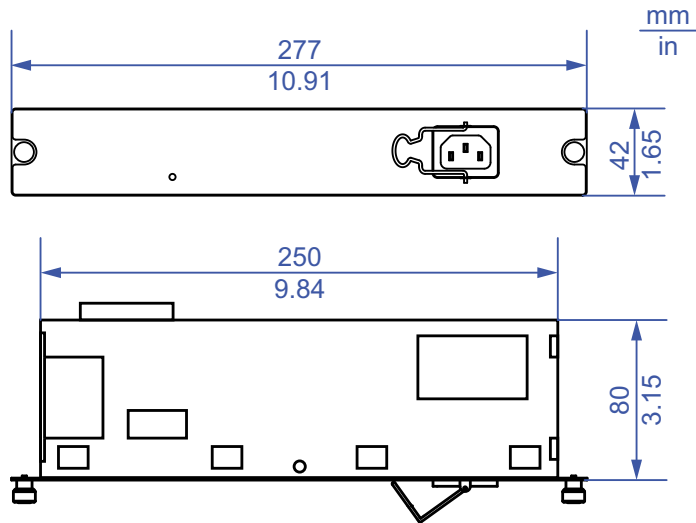

Figure 39: Dimension drawings: power supply unit module

7.7.3 Fan module

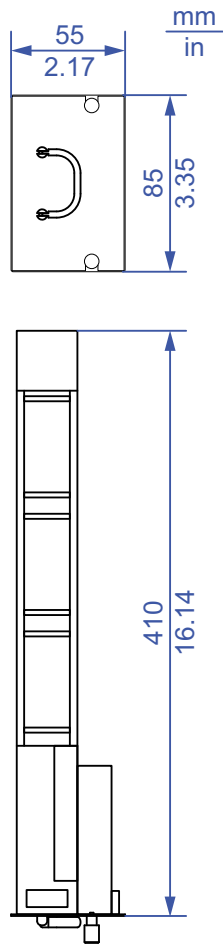

Figure 40: Dimension drawings: fan module

7.7.4 Media modules

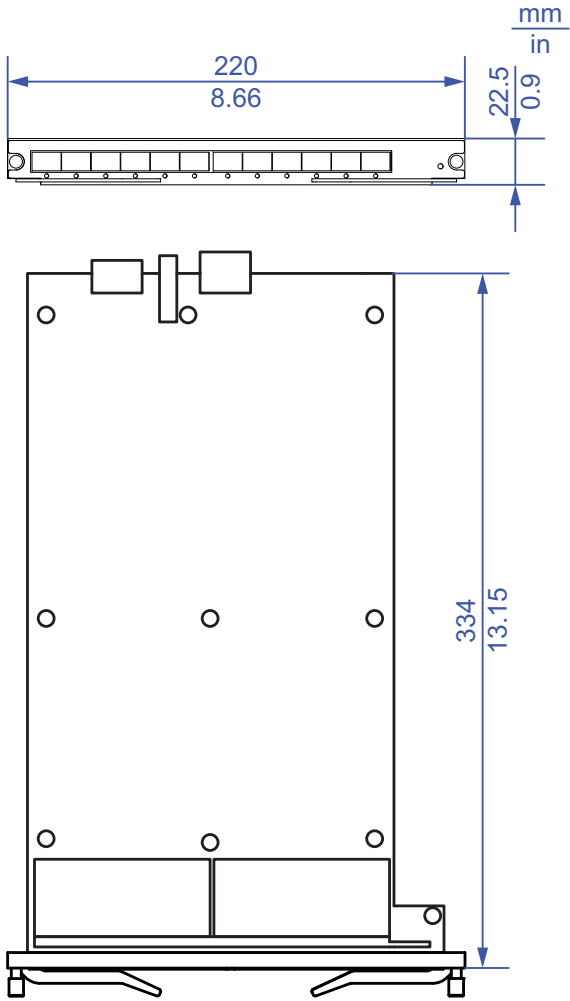

Figure 41: Dimension drawings: media modules

7.8 EMC and immunity

EMC interference emission		Standard applications	Railway applications (trackside)
EN 55032	Class A	Fulfilled	Fulfilled
FCC 47 CFR Part 15	Class A	Fulfilled	Fulfilled
EN 61000-6-4		Fulfilled	Fulfilled
EMC interference immunity		Standard applications^a	Railway applications (trackside)^b
Electrostatic discharge			
EN 61000-4-2	Contact discharge	±4 kV	±6 kV
EN 61000-4-2	Air discharge	±8 kV	±8 kV
Electromagnetic field			
EN 61000-4-3	80 MHz ... 3000 MHz	max. 10 V/m	max. 20 V/m
Fast transients (burst)			
EN 61000-4-4	Supply voltage connection	±2 kV	±2 kV
EN 61000-4-4	Data line	±4 kV	±2 kV
Voltage surges - AC supply connection			
EN 61000-4-5	line/ground	±2 kV	±2 kV
EN 61000-4-5	line/line	±1 kV	±1 kV
Voltage surges - data line			
EN 61000-4-5	line/ground	±1 kV	±2 kV
Conducted disturbances			
EN 61000-4-6	150 kHz ... 80 MHz	10 V	10 V

a. According to EN 61000-6-2.

b. According to EN 50121-4.

Immunity		Standard applications	Railway applications (trackside)
IEC 60068-2-6, test Fc	Vibration	5 Hz ... 8.4 Hz with 3.5 mm (0.14 in) amplitude	—
		8.4 Hz ... 150 Hz with 1 g	—
IEC 60068-2-27, test Ea	Shock	15 g at 11 ms	—

7.9 Network range

Note: The line lengths specified for the transceivers apply for the respective fiber data (fiber attenuation and Bandwidth Length Product (BLP)/ Dispersion).

7.9.1 10/100/1000 Mbit/s twisted pair port

10/100/1000 Mbit/s twisted pair port	
Length of a twisted pair segment	max. 100 m (328 ft) (for Cat5e cable)

Table 9: Network range: 10/100/1000 Mbit/s twisted pair port

7.9.2 Fast Ethernet SFP transceiver

Product code	Mode ^a	Wave length	Fiber	System attenuation	Example for F/O line length ^b	Fiber attenuation	BLP/Dispersion
M-FAST-SFP-MM/LC...	MM	1310 nm	50/125 μm	0 dB ... 8 dB	0 km ... 5 km (0 mi ... 3.11 mi)	1.0 dB/km	800 MHz×km
M-FAST-SFP-MM/LC...	MM	1310 nm	62.5/125 μm	0 dB ... 11 dB	0 km ... 4 km (0 mi ... 2.49 mi)	1.0 dB/km	500 MHz×km
M-FAST-SFP-SM/LC...	SM	1310 nm	9/125 μm	0 dB ... 13 dB	0 km ... 25 km (0 mi ... 15.53 mi)	0.4 dB/km	3.5 ps/(nm×km)
M-FAST-SFP-SM+/LC...	SM	1310 nm	9/125 μm	10 dB ... 29 dB	25 km ... 65 km (15.53 mi ... 40.39 mi)	0.4 dB/km	3.5 ps/(nm×km)
M-FAST-SFP-LH/LC...	SM	1550 nm	9/125 μm	10 dB ... 29 dB	47 km ... 104 km (29.20 mi ... 64.62 mi)	0.25 dB/km	19 ps/(nm×km)
M-FAST-SFP-LH/LC...	SM	1550 nm	9/125 μm	10 dB ... 29 dB	55 km ... 140 km (14.29 mi ... 86.99 mi)	0.18 dB/km ^c	18 ps/(nm×km)
SFP-FAST-MM/LC ^d	MM	1310 nm	50/125 μm	0 dB ... 8 dB	0 km ... 5 km (0 mi ... 3.11 mi)	1.0 dB/km	800 MHz×km
SFP-FAST-MM/LC EEC ^d	MM	1310 nm	62.5/125 μm	0 dB ... 11 dB	0 km ... 4 km (0 mi ... 2.49 mi)	1.0 dB/km	500 MHz×km
SFP-FAST-SM/LC ^d	SM	1310 nm	9/125 μm	0 dB ... 13 dB	0 km ... 25 km (0 mi ... 15.53 mi)	0.4 dB/km	3.5 ps/(nm×km)
SFP-FAST-SM/LC EEC ^d	SM	1310 nm	9/125 μm	0 dB ... 13 dB	0 km ... 25 km (0 mi ... 15.53 mi)	0.4 dB/km	3.5 ps/(nm×km)

Table 10: F/O port 100BASE-FX (SFP Fiber Optic Fast Ethernet Transceiver)

- MM = Multimode, SM = Singlemode, LH = Singlemode Longhaul
- Including 3 dB system reserve when compliance with the fiber data is observed.
- With ultra-low-loss optical fiber.
- You will find further information on certifications on the Internet on the Hirschmann product pages (www.hirschmann.com).

7.9.3 Bidirectional Fast Ethernet SFP transceiver

Product code	Mode ^a	Wave length TX	Wave length RX	Fiber	System attenuation	Example for F/O line length ^b	Fiber attenuation	BLP/Dispersion
SFP-FAST-BA MM/LC EEC	MM	1310 nm	1550 nm	50/125 μm 62.5/125 μm	0 dB ... 16 dB	0 km ... 2 km (0 mi ... 1.24 mi)	1.0 dB/km	800 MHz×km 500 MHz×km
SFP-FAST-BB MM/LC EEC	MM	1550 nm	1310 nm	50/125 μm 62.5/125 μm	0 dB ... 16 dB	0 km ... 2 km (0 mi ... 1.24 mi)	1.0 dB/km	800 MHz×km 500 MHz×km
SFP-FAST-BA SM/LC EEC	SM	1310 nm	1550 nm	9/125 μm	0 dB ... 18 dB	0 km ... 20 km (0 mi ... 12.43 mi)	0.4 dB/km	3.5 ps/(nm×km)
SFP-FAST-BB SM/LC EEC	SM	1550 nm	1310 nm	9/125 μm	0 dB ... 18 dB	0 km ... 20 km (0 mi ... 12.43 mi)	0.25 dB/km	19 ps/(nm×km)
SFP-FAST-BA SM+/LC EEC	SM	1310 nm	1550 nm	9/125 μm	0 dB ... 29 dB	0 km ... 60 km (0 mi ... 37.29 mi)	0.4 dB/km	3.5 ps/(nm×km)
SFP-FAST-BB SM+/LC EEC	SM	1550 nm	1310 nm	9/125 μm	0 dB ... 29 dB	0 km ... 60 km (0 mi ... 37.29 mi)	0.25 dB/km	19 ps/(nm×km)

Table 11: F/O port (bidirectional Fast Ethernet SFP transceiver)

- a. MM = Multimode, SM = Singlemode, LH = Singlemode Longhaul
- b. Including 3 dB system reserve when compliance with the fiber data is observed.

7.9.4 Gigabit Ethernet SFP transceiver

Product code	Mode ^a	Wave length	Fiber	System attenuation	Example for F/O line length ^b	Fiber attenuation	BLP/Dispersion
M-SFP-SX/LC...	MM	850 nm	50/125 μm	0 dB ... 7.5 dB	0 km ... 0.55 k (0 mi ... 0.34 mi)	3.0 dB/km	400 MHz×km
M-SFP-SX/LC...	MM	850 nm	62.5/125 μm	0 dB ... 7.5 dB	0 km ... 0.275 km (0 mi ... 0.17 mi)	3.2 dB/km	200 MHz×km
M-SFP-MX/LC...	MM	1310 nm	50/125 μm	0 dB ... 12 dB	0 km ... 1.5 km (0 mi ... 0.93 mi)	1.0 dB/km	800 MHz×km

Table 12: F/O port 1000BASE-FX (SFP fiber optic Gigabit Ethernet Transceiver)

Product code	Mode ^a	Wave length	Fiber	System attenuation	Example for F/O line length ^b	Fiber attenuation	BLP/Dispersion
M-SFP-MX/LC...	MM	1310 nm	62.5/125 μm	0 dB ... 12 dB	0 km ... 50 km (0 mi ... 31.06 mi)	1.0 dB/km	500 MHz×km
M-SFP-LX/LC...	MM	1310 nm ^c	50/125 μm	0 dB ... 10.5 dB	0 km ... 0.55 km (0 mi ... 0.34 mi)	1.0 dB/km	800 MHz×km
M-SFP-LX/LC...	MM	1310 nm ^d	62.5/125 μm	0 dB ... 10.5 dB	0 km ... 0.55 km (0 mi ... 0.34 mi)	1.0 dB/km	500 MHz×km
M-SFP-LX/LC...	SM	1310 nm	9/125 μm	0 dB ... 10.5 dB	0 km ... 20 km (0 mi ... 12.43 mi) ^e	0.4 dB/km	3.5 ps/(nm×km)
M-SFP-LX+/LC...	SM	1310 nm	9/125 μm	5 dB ... 20 dB	14 km ... 42 km (8.70 mi ... 26.10 mi)	0.4 dB/km	3.5 ps/(nm×km)
M-SFP-LH/LC...	LH	1550 nm	9/125 μm	5 dB ... 22 dB	23 km ... 80 km (14.29 mi ... 49.71 mi)	0.25 dB/km	19 ps/(nm×km)
M-SFP-LH+/LC	LH	1550 nm	9/125 μm	15 dB ... 30 dB	71 km ... 108 km (44.12 mi ... 67.11 mi)	0.25 dB/km	19 ps/(nm×km)
M-SFP-LH+/LC	LH	1550 nm	9/125 μm	15 dB ... 30 dB	71 km ... 128 km (44.12 mi ... 79.54 mi)	0.21 dB/km (typically)	19 ps/(nm×km)
M-SFP-LH+/LC EEC	LH	1550 nm	9/125 μm	13 dB ... 32 dB	62 km ... 116 km (38.52 mi ... 72.07 mi)	0.25 dB/km	19 ps/(nm×km)
M-SFP-LH+/LC EEC	LH	1550 nm	9/125 μm	13 dB ... 32 dB	62 km ... 138 km (38.52 mi ... 85.75 mi)	0.21 dB/km (typically)	19 ps/(nm×km)
SFP-GIG-LX/LC...	MM	1310 nm ^f	50/125 μm	0 dB ... 10.5 dB	0 km ... 0.55 km (0 mi ... 0.34 mi)	1.0 dB/km	800 MHz×km
SFP-GIG-LX/LC...	MM	1310 nm ^g	62.5/125 μm	0 dB ... 10.5 dB	0 km ... 0.55 km (0 mi ... 0.34 mi)	1.0 dB/km	500 MHz×km
SFP-GIG-LX/LC...	SM	1310 nm	9/125 μm	0 dB ... 10.5 dB	0 km ... 20 km (0 mi ... 12.43 mi) ^h	0.4 dB/km	3.5 ps/(nm×km)

Table 12: F/O port 1000BASE-FX (SFP fiber optic Gigabit Ethernet Transceiver)

- MM = Multimode, SM = Singlemode, LH = Singlemode Longhaul
- Including 3 dB system reserve when compliance with the fiber data is observed.
- With F/O adapter compliant with IEEE 802.3-2002 Clause 38 (single-mode fiber offset-launch mode conditioning patch cord).
- With F/O adapter compliant with IEEE 802.3-2002 Clause 38 (single-mode fiber offset-launch mode conditioning patch cord).
- Including 2.5 dB system reserve when compliance with the fiber data is observed.

- f. With F/O adapter compliant with IEEE 802.3-2002 Clause 38 (single-mode fiber offset-launch mode conditioning patch cord).
- g. With F/O adapter compliant with IEEE 802.3-2002 Clause 38 (single-mode fiber offset-launch mode conditioning patch cord).
- h. Including 2.5 dB system reserve when compliance with the fiber data is observed.

7.9.5 Bidirectional Gigabit Ethernet SFP transceiver

Product code	Mode ^a	Wavelength TX	Wavelength RX	Fiber	System attenuation	Example for F/O line length ^b	Fiber attenuation	BLP/Dispersion
M-SFP-BIDI Type A LX/LC EEC	SM	1310 nm	1550 nm	9/125 µm	0 dB ... 11 dB	0 km ... 20 km (0 mi ... 12.43 mi)	0.4 dB/km	3.5 ps/(nm×km)
M-SFP-BIDI Type B LX/LC EEC	SM	1550 nm	1310 nm	9/125 µm	0 dB ... 11 dB	0 km ... 20 km (0 mi ... 12.43 mi)	0.25 dB/km	19 ps/(nm×km)
M-SFP-BIDI Type A LH/LC EEC	LH	1490 nm	1590 nm	9/125 µm	5 dB ... 24 dB	23 km ... 80 km (14.29 mi ... 49.71 mi)	0.25 dB/km	19 ps/(nm×km)
M-SFP-BIDI Type B LH/LC EEC	LH	1590 nm	1490 nm	9/125 µm	5 dB ... 24 dB	23 km ... 80 km (14.29 mi ... 49.71 mi)	0.25 dB/km	19 ps/(nm×km)
SFP-GIG-BA LX/LC EEC	SM	1310 nm	1550 nm	9/125 µm	0 dB ... 15 dB	0 km ... 20 km (0 mi ... 12.43 mi)	0.4 dB/km	3.5 ps/(nm×km)
SFP-GIG-BB LX/LC EEC	SM	1550 nm	1310 nm	9/125 µm	0 dB ... 15 dB	0 km ... 20 km (0 mi ... 12.43 mi)	0.25 dB/km	19 ps/(nm×km)
SFP-GIG-BA LX+/LC EEC	SM	1310 nm	1550 nm	9/125 µm	3 dB ... 20 dB	12 km ... 40 km (7.45 mi ... 24.86 mi)	0.4 dB/km	3.5 ps/(nm×km)
SFP-GIG-BB LX+/LC EEC	SM	1550 nm	1310 nm	9/125 µm	3 dB ... 20 dB	12 km ... 40 km (7.45 mi ... 24.86 mi)	0.25 dB/km	19 ps/(nm×km)
SFP-GIG-BA LH/LC EEC	LH	1490 nm	1550 nm	9/125 µm	4 dB ... 24 dB	19 km ... 80 km (11.80 mi ... 49.71 mi)	0.25 dB/km	19 ps/(nm×km)
SFP-GIG-BB LH/LC EEC	LH	1550 nm	1490 nm	9/125 µm	4 dB ... 24 dB	19 km ... 80 km (11.80 mi ... 49.71 mi)	0.25 dB/km	19 ps/(nm×km)

Table 13: F/O port (bidirectional Gigabit Ethernet SFP transceiver)

- a. MM = Multimode, SM = Singlemode, LH = Singlemode Longhaul
- b. Including 3 dB system reserve when compliance with the fiber data is observed.

7.9.6 2.5 Gigabit Ethernet SFP transceiver

Product code	Mode ^a	Wave length	Fiber	System attenuation	Example for F/O line length ^b	Fiber attenuation	BLP/Dispersion
M-SFP-2.5-MM/LC EEC	MM	850 nm	50/125 μ m	0 dB ... 4 dB	0.55 km (0.34 mi)	3.5 dB/km	2000 MHz \times km (OM3)
M-SFP-2.5-MM/LC EEC	MM	850 nm	50/125 μ m	0 dB ... 4 dB	0.4 km (0.25 mi)	3.5 dB/km	500 MHz \times km (OM2)
M-SFP-2.5-MM/LC EEC	MM	850 nm	62.5/125 μ m	0 dB ... 4 dB	0.17 km (0.11 mi)	3.5 dB/km	200 MHz \times km (OM1)
M-SFP-2.5-SM-/LC EEC	SM	1310 nm	9/125 μ m	0 dB ... 8.5 dB	5 km (3.11 mi)	0.4 dB/km	3.5 ps/(nm \times km)
M-SFP-2.5-SM/LC EEC	SM	1310 nm	9/125 μ m	0 dB ... 13 dB	20 km (12.43 mi)	0.4 dB/km	3.5 ps/(nm \times km)
M-SFP-2.5-SM+/LC EEC	SM	1310 nm	9/125 μ m	12 dB ... 25 dB	45 km (27.96 mi)	0.4 dB/km	3.5 ps/(nm \times km)
M-SFP-2.5-LH/LC	LH	1551 nm	9/125 μ m	14 dB ... 28 dB	80 km (49.71 mi) ^c	0.25 dB/km	19 ps/(nm \times km)

Table 14: F/O port 2.5 Gbit/s (SFP fiber optic Gigabit Ethernet transceiver)

- a. MM = Multimode, SM = Singlemode, LH = Singlemode Longhaul
b. Including 3 dB system reserve when compliance with the fiber data is observed.
c. Typically the DWDM (Dense Wave Division Multiplexing) links have filters because the remaining attenuation budget is consumed by the filters. For point-to-point connections without filters and with max. 1.5 dB of connector losses you can cover up to 59 mi (95 km).

7.9.7 10 Gigabit Ethernet SFP+ transceiver

Product code	Mode ^a	Wave length	Fiber	System attenuation	Example for F/O line length ^b	Fiber attenuation	BLP/dispersion
M-SFP-10-SR/LC EEC	MM	850 nm	50/125 μ m	0 dB ... 8.1 dB	0.066 km (0.041 mi)	3 dB/km	400 MHz \times km
M-SFP-10-SR/LC EEC	MM	850 nm	50/125 μ m	0 dB ... 8.1 dB	0.082 km (0.051 mi)	3 dB/km	500 MHz \times km (OM2)
M-SFP-10-SR/LC EEC	MM	850 nm	50/125 μ m	0 dB ... 8.1 dB	0.3 km (0.186 mi)	3 dB/km	2000 MHz \times km (OM3)
M-SFP-10-SR/LC EEC	MM	850 nm	50/125 μ m	0 dB ... 8.1 dB	0.4 km (0.25 mi)	3 dB/km	4700 MHz \times km (OM4)
M-SFP-10-SR/LC EEC	MM	850 nm	62.5/125 μ m	0 dB ... 8.1 dB	0.026 km (0.016 mi)	3.2 dB/km	160 MHz \times km
M-SFP-10-SR/LC EEC	MM	850 nm	62.5/125 μ m	0 dB ... 8.1 dB	0.033 km (0.021 mi)	3.2 dB/km	200 MHz \times km (OM1)

Table 15: F/O port 10 Gbit/s (SFP+ fiber optic Gigabit Ethernet transceiver)

Product code	Mode ^a	Wave length	Fiber	System attenuation	Example for F/O line length ^b	Fiber attenuation	BLP/dispersion
M-SFP-10-LR/LC EEC	SM	1310 nm	9/125 μm	0 dB ... 7.4 dB	10 km (6.21 mi)	0.4 dB/km	3.5 ps/(nm×km)
M-SFP-10-ER/LC EEC	LH	1550 nm	9/125 μm	3 dB ... 15 dB	10 km ... 40 km (6.21 mi ... 24.86 mi)	0.25 dB/km	19 ps/(nm×km)
M-SFP-10-ZR/LC	LH	1550 nm	9/125 μm	11 dB ... 22 dB	40 km ... 80 km (24.86 mi ... 49.71 mi)	0.25 dB/km	19 ps/(nm×km)

Table 15: F/O port 10 Gbit/s (SFP+ fiber optic Gigabit Ethernet transceiver)

- a. MM = Multimode, SM = Singlemode, LH = Singlemode Longhaul
- b. Including 3 dB system reserve when compliance with the fiber data is observed.

8 Scope of delivery

8.1 Basic device

Amount	Article
1 ×	Device
1 ×	Safety and general information sheet
1 ×	3-pin terminal block for signal contact
1 ×	Fan module D4K-AIR
4 ×	Cover panel for media module slot
1 ×	Cover panel for power supply module slot

8.2 Media modules

Amount	Article
1 ×	Media module
1 ×	Safety and general information sheet
1 ×	2-pin terminal block for the PoE supply voltage (exclusively with media module D4K-10TP-PoE)

8.3 Power supply units

Amount	Article
1 ×	Power supply module
1 ×	Safety and general information sheet

8.4 Fan module

Amount	Article
1 ×	Fan module D4K-AIR
1 ×	Safety and general information sheet

9 Order numbers

DRAGON MACH4000-48G+4X-L2A	942 154-001
DRAGON MACH4000-48G+4X-L3A-UR	942 154-002
DRAGON MACH4000-48G+4X-L3A-MR	942 154-003
DRAGON MACH4500-80G+8X-L2A	942 153-001
DRAGON MACH4500-80G+8X-L3A-UR	942 153-002
DRAGON MACH4500-80G+8X-L3A-MR	942 153-003
Fan module D4K-AIR	942 157-001
Power supply unit (PSU) D4K-PSU-300W-HV	942 156-001
Media module D4K-12TP-RJ45	942 155-001
Media module D4K-10TP-PoE	942 294-001
Media module D4K-12SFP	942 155-501
Cover panel for media module slot	942 222-001
Cover panel for power supply unit slot	942 222-002

10 Accessories

Note that products recommended as accessories may have different characteristics to those of the device, which may limit the application range of the overall system. For example, if you add an accessory with IP20 to a device with IP65, the degree of protection of the overall system is reduced to IP20.

Fast Ethernet SFP transceiver	Order number
M-FAST SFP-TX/RJ45	942 098-001
M-FAST SFP-TX/RJ45 EEC	942 098-002
The following operating conditions apply to twisted pair transceivers:	
<ul style="list-style-type: none"> ▶ Usable with: <ul style="list-style-type: none"> - HiOS as of software version 03.0.00 - for PRP ports on RSP devices, as of software version 02.0.01 - for PRP ports on EES devices, as of software version 02.0.02 - Classic switch software as of software version 08.0.00 - HiSecOS as of software version 01.2.00 ▶ Longer RSTP switching times and link loss detection times compared to twisted pair ports provided by the device directly. ▶ Not applicable for combo ports. ▶ Not applicable for ports which support only Gigabit Ethernet. ▶ It is currently not possible to set autocrossing manually. 	
M-FAST SFP-MM/LC	943 865-001
M-FAST SFP-MM/LC EEC	943 945-001
M-FAST SFP-SM/LC	943 866-001
M-FAST SFP-SM/LC EEC	943 946-001
M-FAST SFP-SM+/LC	943 867-001
M-FAST SFP-SM+/LC EEC	943 947-001
M-FAST SFP-LH/LC	943 868-001
M-FAST SFP-LH/LC EEC	943 948-001
SFP-FAST-MM/LC ^a	942 194-001
SFP-FAST-MM/LC EEC ^a	942 194-002
SFP-FAST-SM/LC ^a	942 195-001
SFP-FAST-SM/LC EEC ^a	942 195-002

Table 16: Accessory: Fast Ethernet SFP transceiver

a. You will find further information on certifications on the Internet on the Hirschmann product pages (www.hirschmann.com).

Bidirectional Fast Ethernet SFP transceivers ^a	Order number
SFP-FAST-BA MM/LC EEC	942 204-001
SFP-FAST-BB MM/LC EEC	942 204-002
SFP-FAST-BA SM/LC EEC	942 205-001
SFP-FAST-BB SM/LC EEC	942 205-002
SFP-FAST-BA SM+/LC EEC	942 206-001
SFP-FAST-BB SM+/LC EEC	942 206-002

Table 17: Accessory: Bidirectional Fast Ethernet SFP transceiver

a. You find further information on certifications on the Internet on the Hirschmann product pages (www.hirschmann.com).

Gigabit Ethernet SFP transceiver	Order number
M-SFP-TX/RJ45	943 977-001
M-SFP-SX/LC	943 014-001
M-SFP-SX/LC EEC	943 896-001
M-SFP-MX/LC EEC	942 108-001
M-SFP-LX/LC	943 015-001
M-SFP-LX/LC EEC	943 897-001
M-SFP-LX+/LC	942 023-001
M-SFP-LX+/ LC EEC	942 024-001
M-SFP-LH/LC	943 042-001
M-SFP-LH/LC EEC	943 898-001
M-SFP-LH+/LC	943 049-001
M-SFP-LH+/LC EEC	942 119-001
SFP-GIG-LX/LC ^a	942 196-001
SFP-GIG-LX/LC EEC ^a	942 196-002

a. You will find further information on certifications on the Internet on the Hirschmann product pages (www.hirschmann.com).

Bidirectional Gigabit Ethernet SFP transceiver	Order number
M-SFP-BIDI Type A LX/LC EEC	943 974-001
M-SFP-BIDI Type B LX/LC EEC	943 974-002
M-SFP-BIDI Type A LH/LC EEC	943 975-001
M-SFP-BIDI Type B LH/LC EEC	943 975-002
M-SFP-BIDI Bundle LX/LC EEC (Type A + B)	943 974-101
M-SFP-BIDI Bundle LH/LC EEC (Type A + B)	943 975-101
SFP-GIG-BA LX/LC EEC ^a	942 207-001
SFP-GIG-BB LX/LC EEC ^a	942 207-002
SFP-GIG-BA LX+/LC EEC ^a	942 208-001
SFP-GIG-BB LX+/LC EEC ^a	942 208-002
SFP-GIG-BA LH/LC EEC ^a	942 209-001
SFP-GIG-BB LH/LC EEC ^a	942 209-002

a. You will find further information on certifications on the Internet on the Hirschmann product pages (www.hirschmann.com).

2.5 Gigabit Ethernet SFP transceiver (applies exclusively to the basic device)	Order number
M-SFP-2.5-MM/LC EEC	942 162-001
M-SFP-2.5-SM-/LC EEC	942 163-001
M-SFP-2.5-SM/LC EEC	942 164-001
M-SFP-2.5-SM+/LC EEC	942 165-001
M-SFP-2.5-LH/LC	942 220-001

10 Gigabit Ethernet SFP transceiver (only applies to the basic device)	Order number
M-SFP-10-SR/LC-EEC	942 210-001
M-SFP-10-LR/LC-EEC	942 211-001

10 Gigabit Ethernet SFP transceiver (only applies to the basic device)	Order number
M-SFP-10-ER/LC-EEC	942 212-001
M-SFP-10-ZR/LC	942 213-001
SFP-10-DAC-05m	942 280-001
SFP-10-DAC-1m	942 280-002
SFP-10-DAC-2m	942 280-003
SFP-10-DAC-4m	942 280-004

Other accessories	Order number
AutoConfiguration Adapter ACA22-USB (EEC)	942 124-001
AutoConfiguration Adapter ACA31	942 074-001
Terminal cable: RJ45 on Sub-D, 9-pin	942 097-001
Terminal cable: RJ45 on USB	942 096-001
Non-heating appliance cable (Euro model)	942 271-001
3-pin terminal block for signal contact (10 pieces)	942 272-001
Protection cap for RJ45 socket (50 pieces)	943 936-001
Protection cap for SFP slot (25 pieces)	943 942-001
Network management software Industrial HiVision	943 156-xxx

11 Underlying technical standards

Name	
FCC 47 CFR Part 15	Code of Federal Regulations
IEC 60825-1	Laser product safety
IEEE 802.3	Ethernet
EN 50121-4	Railway applications – EMC – Emission and immunity of the signaling and telecommunications apparatus (Rail Trackside)
EN 55032	Electromagnetic compatibility of multimedia equipment – Emission Requirements
EN 61000-3-2	Electromagnetic compatibility (EMC) – part 3-2: Threshold values – threshold values for harmonic currents (device input current \leq 16 A per conductor)
EN 61000-3-3	Electromagnetic compatibility (EMC) – part 3-3: Threshold values – limitation of voltage changes, voltage fluctuations and flickering in public low power supply networks for devices with a rated current \leq 16 A per conductor that are not subject to any special connection condition
EN 61000-6-2	Electromagnetic compatibility (EMC) – Part 6-2: Generic standards – Immunity for industrial environments
EN 61000-6-4	Electromagnetic compatibility (EMC) – Part 6-4: Generic standards – Emitted interference in industrial environments
EN 61131-2	Programmable controllers – Part 2: Equipment requirements and tests
UL/IEC 61010-1	Safety requirements for electrical equipment for measurement, control and laboratory use
UL/IEC 61010-2-201	Safety requirements for electrical equipment for measurement, control and laboratory use - Part 2-201: Particular requirements for control equipment.

Table 18: List of the technical standards

The device generally fulfills the technical standards named in their current versions.

The device has an approval based on a specific standard exclusively if the approval indicator appears on the device casing.

A Further support

Technical questions

For technical questions, please contact any Hirschmann dealer in your area or Hirschmann directly.

You find the addresses of our partners on the Internet at <http://www.hirschmann.com>.

A list of local telephone numbers and email addresses for technical support directly from Hirschmann is available at <https://hirschmann-support.belden.com>.

This site also includes a free of charge knowledge base and a software download section.

Customer Innovation Center

The Customer Innovation Center is ahead of its competitors on three counts with its complete range of innovative services:

- ▶ Consulting incorporates comprehensive technical advice, from system evaluation through network planning to project planning.
- ▶ Training offers you an introduction to the basics, product briefing and user training with certification.
You find the training courses on technology and products currently available at <https://www.belden.com/solutions/customer-innovation-center>.
- ▶ Support ranges from the first installation through the standby service to maintenance concepts.

With the Customer Innovation Center, you decide against making any compromises in any case. Our client-customized package leaves you free to choose the service components you want to use.

Internet:

<https://www.belden.com/solutions/customer-innovation-center>



HIRSCHMANN

A **BELDEN** BRAND