



**HIRSCHMANN**

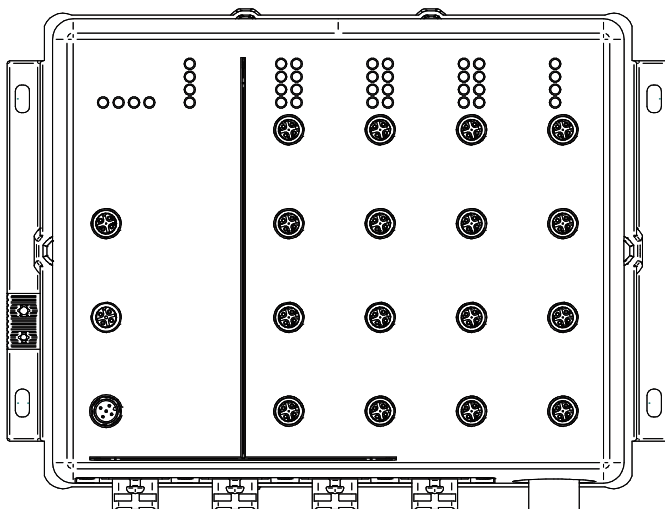
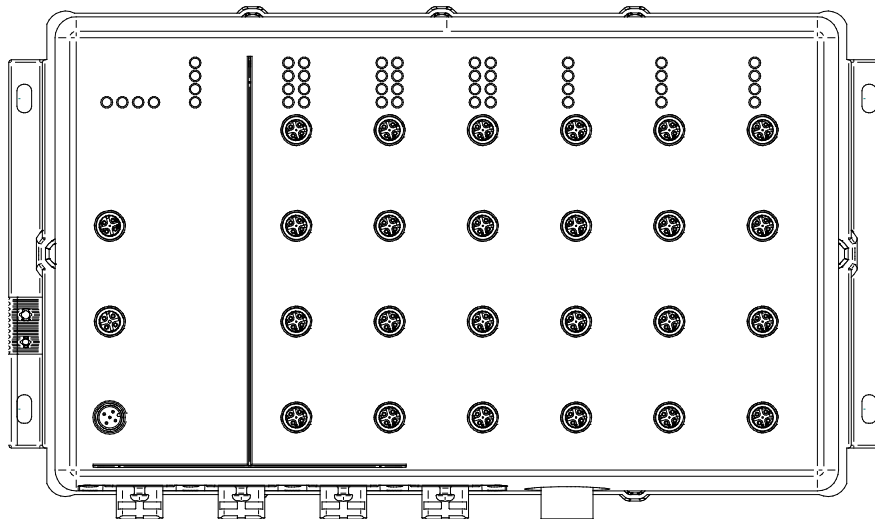
A **BELDEN** BRAND

# User Manual

## Installation

### Managed IP65/67 Switch

### Octopus II



The naming of copyrighted trademarks in this manual, even when not specially indicated, should not be taken to mean that these names may be considered as free in the sense of the trademark and tradename protection law and hence that they may be freely used by anyone.

© 2019 Hirschmann Automation and Control GmbH

Manuals and software are protected by copyright. All rights reserved. The copying, reproduction, translation, conversion into any electronic medium or machine scannable form is not permitted, either in whole or in part. An exception is the preparation of a backup copy of the software for your own use.

The performance features described here are binding only if they have been expressly agreed when the contract was made. This document was produced by Hirschmann Automation and Control GmbH according to the best of the company's knowledge. Hirschmann reserves the right to change the contents of this document without prior notice. Hirschmann can give no guarantee in respect of the correctness or accuracy of the information in this document.

Hirschmann can accept no responsibility for damages, resulting from the use of the network components or the associated operating software. In addition, we refer to the conditions of use specified in the license contract.

You can get the latest version of this manual on the Internet at the Hirschmann product site ([www.hirschmann.com](http://www.hirschmann.com)).

Hirschmann Automation and Control GmbH  
Stuttgarter Str. 45-51  
72654 Neckartenzlingen  
Germany

# Contents

<b>Safety instructions</b>	<b>5</b>
<b>About this manual</b>	<b>13</b>
<b>Key</b>	<b>14</b>
<b>1 Description</b>	<b>15</b>
1.1 General description	15
1.2 Device name and product code	15
1.3 Device view	22
1.4 Power supply	25
1.4.1 Supply voltage with the characteristic value BB	25
1.4.2 Supply voltage with the characteristic value FF	25
1.4.3 Supply voltage with the characteristic value HH	25
1.4.4 Supply voltage with the characteristic value M9	25
1.4.5 Supply voltage with the characteristic value N9	25
1.4.6 Supply voltage with the characteristic value QQ	26
1.4.7 Supply voltage with the characteristic value PP	26
1.5 Ethernet ports	26
1.5.1 Twisted pair	26
1.5.2 Support of PoE(+)	27
1.5.3 Optical fiber	29
1.5.4 Pin assignments	30
1.6 Display elements	31
1.6.1 Device state	31
1.6.2 Port status	32
1.7 Management interfaces	32
1.7.1 USB interface	32
1.7.2 V.24 interface (external management)	33
1.8 Signal contact	34
<b>2 Installation</b>	<b>35</b>
2.1 Checking the package contents	35
2.2 Installing and grounding the device	35
2.2.1 Installing the device	35

2.2.2	Grounding the device	36
2.3	Connecting the ferrite	37
2.4	Connecting the power supply and the signal contact lines	37
2.4.1	Supply voltage with the characteristic value BB	37
2.4.2	Supply voltage with the characteristic value FF	39
2.4.3	Supply voltage with the characteristic value HH	39
2.4.4	Supply voltage with the characteristic value M9	40
2.4.5	Supply voltage with the characteristic value N9	40
2.4.6	Supply voltage with the characteristic value QQ	42
2.4.7	Supply voltage with the characteristic value PP	42
2.4.8	Signal contact	44
2.5	Operating the device	44
2.6	Connecting data cables	45
2.7	Filling out the inscription label	45
<b>3</b>	<b>Making basic settings</b>	<b>46</b>
<b>4</b>	<b>Monitoring the ambient air temperature</b>	<b>47</b>
<b>5</b>	<b>Maintenance and service</b>	<b>48</b>
<b>6</b>	<b>Disassembly</b>	<b>49</b>
<b>7</b>	<b>Technical data</b>	<b>50</b>
<b>A</b>	<b>Further support</b>	<b>65</b>

# Safety instructions

## **WARNING**

### **UNCONTROLLED MACHINE ACTIONS**

To avoid uncontrolled machine actions caused by data loss, configure all the data transmission devices individually.

Before you start any machine which is controlled via data transmission, be sure to complete the configuration of all data transmission devices.

**Failure to follow these instructions can result in death, serious injury, or equipment damage.**

### ■ **General safety instructions**

You operate this device with electricity. Improper usage of the device entails the risk of physical injury or significant property damage. The proper and safe operation of this device depends on proper handling during transportation, proper storage and installation, and careful operation and maintenance procedures.

- Before connecting any cable, read this document, and the safety instructions and warnings.
- Operate the device with undamaged components exclusively.
- The device is free of any service components. In case of a damaged or malfunctioning device, turn off the supply voltage and return the device to Hirschmann for inspection.

### ■ **Qualification requirements for personnel**

- Only allow qualified personnel to work on the device.

Qualified personnel have the following characteristics:

- ▶ Qualified personnel are properly trained. Training as well as practical knowledge and experience make up their qualifications. This is the prerequisite for grounding and labeling circuits, devices, and systems in accordance with current standards in safety technology.
- ▶ Qualified personnel are aware of the dangers that exist in their work.
- ▶ Qualified personnel are familiar with appropriate measures against these hazards in order to reduce the risk for themselves and others.
- ▶ Qualified personnel receive training on a regular basis.

### ■ **Installation site requirements**

- Exclusively for device variants featuring supply voltage with characteristic value M9 or N9:

Install this device solely in a switch cabinet or in an operating site with restricted access, to which maintenance staff have exclusive access.

## ■ Certified usage

- Use the product only for the application cases described in the Hirschmann product information, including this manual.
- Operate the product only according to the technical specifications.  
[See “Technical data” on page 50.](#)
- Connect to the product only components suitable for the requirements of the specific application case.

## ■ Requirements for connecting electrical wires

Before connecting the electrical wires, **always** verify that the requirements listed are complied with.

### All of the following requirements are complied with:

- ▶ The electrical wires are voltage-free.
- ▶ The cables used are permitted for the temperature range of the application case.

Table 1: Requirements for connecting electrical wires

## ■ Requirements for connecting the signal contact

Before connecting the signal contact, **always** verify that the requirements listed are complied with.

### All of the following requirements are complied with:

- ▶ The voltage connected complies with the requirements for a safety extra-low voltage (SELV) as per IEC/EN 60950-1.
- ▶ The connected voltage is limited by a current limitation device or a fuse. Observe the electrical threshold values for the signal contact.  
[See “General technical data” on page 50.](#)

Table 2: Requirements for connecting the signal contact

## ■ Requirements for connecting the grounding

Before connecting the grounding, **always** verify that the requirements listed are complied with.

Device variant	Requirements
Only for device variants featuring supply voltage with characteristic value M9:	The wire diameter of the ground conductor in the power supply cable is the same size as or bigger than the wire diameter of the power supply cables, however of at least 0.75 mm <sup>2</sup> (AWG18).
<b>All variants</b>	The wire diameter of the ground conductor is at least 1.5 mm <sup>2</sup> at the device casing. When connecting the provided cable lug, use a professional crimping tool specified for the wire size. Follow the instructions of the crimping tool. The pull out force of the crimped connection is at least 135 N according to the technical standard IEC 60352-2.

Table 3: Requirements for connecting the grounding

## ■ Requirements for connecting the supply voltage

Before connecting the supply voltage, **always** verify that the requirements listed are complied with.

Device variant	Requirements						
<b>All variants</b>	<p><b>All</b> of the following requirements are complied with:</p> <ul style="list-style-type: none"> <li>▶ The supply voltage corresponds to the voltage specified on the type plate of the device.</li> <li>▶ The power supply conforms to overvoltage category I or II.</li> <li>▶ The power supply has an easily accessible disconnecting device (for example a switch or a plug). This disconnecting device is clearly identified. So in the case of an emergency, it is clear which disconnecting device belongs to which power supply cable.</li> <li>▶ Relevant for North America: The power supply cables are suitable for ambient air temperatures of at least 167 °F (75 °C). The power supply cable wires are made of copper.</li> </ul>						
Exclusively for device variants featuring supply voltage with characteristic value BB, FF, HH, QQ:	<p>The power supply cable is suitable for the voltage, the current and the physical load. Hirschmann recommends a wire diameter of 0.5 mm<sup>2</sup> to 0.75 mm<sup>2</sup> (AWG20 up to AWG18).</p>						
	<p>The following requirements are <b>alternatively</b> complied with:</p>						
	<table border="0"> <tr> <td style="border-bottom: 1px solid black;">Alternative 1</td> <td style="border-bottom: 1px solid black;">The power supply complies with the requirements for a limited power source (LPS) as per EN 60950-1.</td> </tr> <tr> <td style="border-bottom: 1px solid black;">Alternative 2</td> <td style="border-bottom: 1px solid black;">Relevant for North America: The power supply complies with the requirements according to NEC Class 2.</td> </tr> <tr> <td>Alternative 3</td> <td> <p><b>All</b> of the following requirements are complied with:</p> <ul style="list-style-type: none"> <li>▶ The power supply complies with the requirements for a safety extra-low voltage (SELV) as per IEC/EN 60950-1.</li> <li>▶ A fuse suitable for DC voltage is located in the plus conductor of the power supply. The minus conductor is on ground potential. Otherwise, a fuse is also located in the minus conductor. Regarding the properties of this fuse: <a href="#">See "General technical data" on page 50.</a></li> </ul> </td> </tr> </table>	Alternative 1	The power supply complies with the requirements for a limited power source (LPS) as per EN 60950-1.	Alternative 2	Relevant for North America: The power supply complies with the requirements according to NEC Class 2.	Alternative 3	<p><b>All</b> of the following requirements are complied with:</p> <ul style="list-style-type: none"> <li>▶ The power supply complies with the requirements for a safety extra-low voltage (SELV) as per IEC/EN 60950-1.</li> <li>▶ A fuse suitable for DC voltage is located in the plus conductor of the power supply. The minus conductor is on ground potential. Otherwise, a fuse is also located in the minus conductor. Regarding the properties of this fuse: <a href="#">See "General technical data" on page 50.</a></li> </ul>
	Alternative 1	The power supply complies with the requirements for a limited power source (LPS) as per EN 60950-1.					
Alternative 2	Relevant for North America: The power supply complies with the requirements according to NEC Class 2.						
Alternative 3	<p><b>All</b> of the following requirements are complied with:</p> <ul style="list-style-type: none"> <li>▶ The power supply complies with the requirements for a safety extra-low voltage (SELV) as per IEC/EN 60950-1.</li> <li>▶ A fuse suitable for DC voltage is located in the plus conductor of the power supply. The minus conductor is on ground potential. Otherwise, a fuse is also located in the minus conductor. Regarding the properties of this fuse: <a href="#">See "General technical data" on page 50.</a></li> </ul>						

*Table 4: Requirements for connecting the supply voltage*

Device variant	Requirements
Only for device variants featuring supply voltage with characteristic value M9:	<p><b>All</b> of the following requirements are complied with:</p> <ul style="list-style-type: none"> <li>▶ A fuse is located in the outer conductor of the power supply. The neutral conductor is on ground potential at both voltage inputs. Otherwise, a fuse is also located in the neutral conductor. Regarding the properties of this fuse: <a href="#">See “General technical data” on page 50.</a></li> <li>▶ The power supply cable is suitable for the voltage, the current and the physical load. The wire diameter is at least AWG18 (0.75 mm<sup>2</sup>).</li> </ul>
Only for device variants featuring supply voltage with characteristic value N9:	<p><b>All</b> of the following requirements are complied with:</p> <ul style="list-style-type: none"> <li>▶ A fuse suitable for DC voltage is located in the plus conductor of the power supply. The minus conductor is on ground potential. Otherwise, a fuse is also located in the minus conductor. Regarding the properties of this fuse: <a href="#">See “General technical data” on page 50.</a></li> <li>▶ The power supply cable is suitable for the voltage, the current and the physical load. Hirschmann recommends a wire diameter of 0.5 mm<sup>2</sup> to 0.75 mm<sup>2</sup> (AWG20 up to AWG18).</li> </ul>

*Table 4: Requirements for connecting the supply voltage*

Exclusively for device variants featuring supply voltage with characteristic value PP:	<p><b>All</b> of the following requirements are complied with:</p> <ul style="list-style-type: none"> <li>▶ The power supply cable is suitable for the voltage, the current and the physical load. The wire diameter is at least AWG18 (0.75 mm<sup>2</sup>).</li> <li>▶ The power supply inputs of the Octopus II device must not be grounded.</li> </ul> <p>The following requirements are <b>alternatively</b> complied with:</p>
Alternative 1	<ul style="list-style-type: none"> <li>▶ For providing the PoE power, use the power supply unit PC150/110V/54V, which is available as accessory. <a href="#">See “Accessories” on page 63.</a></li> </ul>
Alternative 2	<ul style="list-style-type: none"> <li>▶ For providing the PoE power, use a suitable power supply unit with an insulation strength of 2250 V DC between output and input and between output and casing.</li> <li>▶ The power supply complies with the requirements for a safety extra-low voltage (SELV) as per IEC/EN 60950-1.</li> <li>▶ A fuse suitable for DC voltage is located in the positive conductor of the power supply. Regarding the properties of this fuse: <a href="#">See “General technical data” on page 50.</a></li> </ul>

*Table 5: Requirements for connecting the supply voltage*

## ■ Supply voltage

The supply voltage is connected to the device casing through protective elements exclusively.



## ■ **Shielding ground**

- ▶ The overall shield of a connected shielded twisted pair cable is connected to the ground connection on the metal housing as a conductor.
  - Beware of possible short circuits when connecting a cable section with conductive shielding braiding.
- ▶ Exclusively for device variants featuring supply voltage with characteristic value QQ, PP:  
The overall shield of a connected power supply cable is connected to the ground connection on the metal casing as a conductor.
  - Beware of possible short circuits when connecting a cable section with conductive shielding braiding.

## ■ **Grounding the device**

Grounding the device is by means of a separate ground connection on the device.

- Ground the device before connecting any other cables.
- Disconnect the grounding only after disconnecting all other cables.
- Use toothed washers to ensure good electrical conductivity at the connection.

## ■ **Device casing**

Only technicians authorized by the manufacturer are permitted to open the casing.

- ▶ Exclusively for device variants featuring temperature range characteristic value T:  
At ambient air temperatures > 140 °F (+60 °C):  
The surfaces of the device housing may become hot. Avoid touching the device while it is operating.
- To preserve the suitability of your device for IP65/67, proceed as follows:
  - Remove the provided transport protection caps and the transport protection screws from the device.
  - Seal unused sockets and plugs with your desired type of protection screws which you can order separately.

## ■ **National and international safety regulations**

Verify that the electrical installation meets local or nationally applicable safety regulations.

## ■ E marking

The labeled devices comply with the regulations contained in the following European directive(s):

Regulation No. 10 of the Economic Commission for Europe of the United Nations (UN/ECE): **Devices with an approval are labeled with the E type approval mark.**

For devices labeled with the E type-approval mark, the following installation conditions apply:

Characteristic value	Installation conditions
<b>“Customer-specific version”</b>	
Exclusively for device variants featuring the characteristic value customer-specific version HE (Hirschmann EMV)	▶ No special installation conditions must be taken into account.
All other variants	▶ The entire 24 V power supply network must be installed up to the battery with shielded power supply cables. ▶ The shield must be grounded near the battery.

The product code tells you which properties your device has.  
See [“Device name and product code” on page 15.](#)

## ■ CE marking

The labeled devices comply with the regulations contained in the following European directive(s):

Device variant	Directive
All variants	2014/30/EU (EMC) Directive of the European Parliament and of the Council on the harmonisation of the laws of the Member States relating to electromagnetic compatibility.  2011/65/EU and 2015/863/EU (RoHS) Directive of the European Parliament and of the Council on the restriction of the use of certain hazardous substances in electrical and electronic equipment.
Exclusively for device variants featuring supply voltage with characteristic value M9 or N9:	2014/35/EU Directive of the European Parliament and of the Council on the harmonisation of the laws of the Member States relating to the making available on the market of electrical equipment designed for use within certain voltage limits.

In accordance with the above-named EU directive(s), the EU conformity declaration will be at the disposal of the relevant authorities at the following address:

Hirschmann Automation and Control GmbH  
Stuttgarter Str. 45-51  
72654 Neckartenzlingen  
Germany  
www.hirschmann.com

The product can be used in the industrial sector.

- ▶ Interference immunity: EN 61000-6-2
- ▶ Emitted interference: EN 55032
- ▶ Reliability: EN 60950-1

You find more information on technical standards here:

[“Technical data” on page 50](#)

**Warning!** This is a class A device. This device can cause interference in living areas, and in this case the operator may be required to take appropriate measures.

**Note:** The assembly guidelines provided in these instructions must be strictly adhered to in order to observe the EMC threshold values.

## ■ **LED or laser components**

LED or LASER components according to IEC 60825-1 (2014):

CLASS 1 LASER PRODUCT

CLASS 1 LED PRODUCT

## ■ **FCC note:**

This device complies with part 15 of the FCC rules. Operation is subject to the following two conditions: (1) this device may not cause harmful interference; (2) this device must accept any interference received, including interference that may cause undesired operation.

Appropriate testing has established that this device fulfills the requirements of a class A digital device in line with part 15 of the FCC regulations.

These requirements are designed to provide sufficient protection against interference when the device is being used in a business environment.

The device creates and uses high frequencies and can also radiate these frequencies. If it is not installed and used in accordance with this operating manual, it can cause radio transmission interference. The use of this device in a residential area can also cause interference, and in this case the user is obliged to cover the costs of removing the interference.

## ■ **Recycling note**

After usage, this device must be disposed of properly as electronic waste, in accordance with the current disposal regulations of your county, state, and country.

## About this manual

The “Installation” user manual contains a device description, safety instructions, a description of the display, and the other information that you need to install the device.

Documentation mentioned in the “User Manual Installation” that is not supplied with your device as a printout can be found as PDF files for downloading on the Internet at: <https://www.doc.hirschmann.com>

# Key

The symbols used in this manual have the following meanings:

▶	Listing
□	Work step
■	Subheading

# 1 Description

## 1.1 General description

The device is designed for the special requirements of industrial automation. The device meets the relevant industry standards, provides very high operational reliability, even under extreme conditions, and also long-term reliability and flexibility.

You have numerous options of combining the device characteristics. You can determine the possible combinations using the Configurator which is available in the Belden E-Catalog ([www.e-catalog.beldensolutions.com](http://www.e-catalog.beldensolutions.com)) on the web page of the device.

The devices comply with the degrees of protection IP65/67.

The devices work without a fan.

The redundancy concept allows the network to be reconfigured quickly.

There are convenient options for managing the device. Manage your devices via:

- ▶ Web browser
  - ▶ SSH
  - ▶ Telnet
  - ▶ V.24 interface (locally on the device)
  - ▶ HiDiscovery (software for putting the device into operation)
  - ▶ Network management software (for example Industrial HiVision)
- The Network Management Software Industrial HiVision provides you with options for smooth configuration and monitoring. You find further information on the Internet at the Hirschmann product pages:  
<http://www.hirschmann.com/en/QR/INET-Industrial-HiVision>

## 1.2 Device name and product code

The device name corresponds to the product code. The product code is made up of characteristics with defined positions. The characteristic values stand for specific product properties.

Item	Characteristic	Characteristic value	Description
1 ... 2	Product	OS	Octopus II device
3	Data rate	2	Fast Ethernet ports
		3	Fast Ethernet ports and Gigabit Ethernet ports
4	Hardware type	0	Standard
		4	Standard with PoE(+)
5	(hyphen)	–	
6 ... 7	Number PoE(+) ports	00	0 × PoE(+) ports
		08	8 × PoE(+) ports
		10	10 × PoE(+) ports
		11	11 × PoE(+) ports
		12	12 × PoE(+) ports
		14	14 × PoE(+) ports
		15	15 × PoE(+) ports
8 ... 9	Number Fast Ethernet ports	08	8 × Fast Ethernet ports
		12	12 × Fast Ethernet ports
		16	16 × Fast Ethernet ports
		20	20 × Fast Ethernet ports
		24	24 × Fast Ethernet ports
		28	28 × Fast Ethernet ports
10 ... 11	Number Gigabit Ethernet ports	00	0 × Gigabit Ethernet ports
		02	2 × Gigabit Ethernet ports
		04	4 × Gigabit Ethernet ports
12 ... 13	Configuration of uplink ports 1 and 2	T5	10/100 Mbit/s twisted pair port 4-pin, “D”-coded M12 socket
		R5	10/100 Mbit/s twisted pair port 4-pin, „D“-coded M12 socket with bypass relay
		T6	10/100/1000 Mbit/s twisted pair port 8-pin, “X”-coded M12 socket
		R6	10/100/1000 Mbit/s twisted pair port 8-pin, “X”-coded M12 socket with bypass relay
		99	Not present
		You will find the information on the F/O ports in a separate overview. <a href="#">See table 8 on page 20.</a>	
		14 ... 15	Configuration of uplink ports 3 and 4
R5	10/100 Mbit/s twisted pair port 4-pin, „D“-coded M12 socket with bypass relay		
T6	10/100/1000 Mbit/s twisted pair port 8-pin, “X”-coded M12 socket		
R6	10/100/1000 Mbit/s twisted pair port 8-pin, “X”-coded M12 socket with bypass relay		
You will find the information on the F/O ports in a separate overview. <a href="#">See table 8 on page 20.</a>			
16 ... 17	Configuration of the local ports	T5	10/100 Mbit/s twisted pair port 4-pin, “D”-coded M12 socket

**Table 6: Device name and product code**





Item	Characteristic	Characteristic value	Description
18	(hyphen)	–	
19	Temperature range	V	Standard –40 °F ... +140 °F (–40 °C ... +60 °C)
		T	Extended –40 °F ... +158 °F (–40 °C ... +70 °C)
20 ... 21	Supply voltage	BB	2 voltage inputs for redundant power supply
			Rated voltage 24 V DC
		HH	2 voltage inputs for redundant power supply
			Rated voltage range 36 V DC ... 48 V DC
		FF	2 voltage inputs for redundant power supply
			Rated voltage range 24 V DC ... 48 V DC
		M9	1 voltage input
			Rated voltage range 110 V AC ... 230 V AC, 50 Hz ... 60 Hz
		N9	1 voltage input
			Rated voltage range 72 V DC ... 110 V DC
QQ	2 voltage inputs for redundant power supply		
	Rated voltage range 24 V DC ... 48 V DC		
PP	PoE	2 voltage inputs for redundant power supply	
		 Rated voltage range 47 V DC ... 57 V DC	
	PoE Plus	2 voltage inputs for redundant power supply	
		 Rated voltage range 53 V DC ... 57 V DC	
	Connection type	4-pin, "T"-coded M12 power plug	
22 ... 23	Certificates and declarations	You will find detailed information on the certificates and declarations applying to your device in a separate overview. <a href="#">See table 7 on page 19.</a>	
24 ... 25	Software packages	99	Reserved

Table 6: Device name and product code

Item	Characteristic	Characteristic value	Description
26 ... 27	Customer-specific version	HH	Hirschmann standard
		HA	Hirschmann Angled
		H1	Hirschmann Power Supply Side
		HE	Hirschmann EMV
28	Hardware configuration	S	Standard
		M	Ports 1 and 2: Fast MRP
		P	Ports 1 and 2: PRP
		H	Ports 1 and 2: HSR
		D	Ports 1 and 2: DLR
		N	Ports 1 and 2: 1:1 NAT
29	Software configuration	T	Ports 1 ... 4: Train backbone (ETB)
		E	Entry (without configuration)
		D	DLR
		P	PROFINET/IO
		I	Ethernet/IP
30 ... 31	Software level	B	BDEW
		2S	HiOS Layer 2 Standard
		2A	HiOS Layer 2 Advanced
32 ... 36	Software version	3S	HiOS Layer 3 Standard
		04.1.	Software-Version 04.1
37 ... 38	Maintenance	XX.X.	Current software version
		00	Bugfix version 00
		XX	Current bugfix version

Table 6: Device name and product code

Application case	Certificates and declarations	Characteristic value											
		Z9	Y9	U9	UY	UT	US	T9	TY	S9	SY	R9	
Standard applications	CE	X	X	X	X	X	X	X	X	X	X	X	X
	EN 60950-1	X	X	X	X	X	X	X	X	X	X	X	X
	EN 61131-2	X	X	X	X	X	X	X	X	X	X	X	X
	FCC	X	X	X	X	X	X	X	X	X	X	X	X
	cUL 60950-1		X		X	X	X		X		X		
Navy applications	DNV GL			X	X	X	X						
Railway applications (trackside)	EN 50121-4					X	X	X	X	X	X		
Railway applications (in vehicles)	EN 50155						X			X	X		
Motor vehicle applications	E1												X

*Table 7: Assignment: application cases, certificates and declarations, characteristic values*

Port type	Built-in transceivers	Version	Characteristic value																							
			1M	1S	1P	1L	1A	1B	1C	1D	4M	4S	4P	4L	4A	4B	4C	4D	5M	5S	5P	5L	5A	5B	5C	5D
1000 Mbit/s F/O port	M-SFP-SX/LC-EEC	V1					X																			
		V4													X											
		QODC																						X		
	M-SFP-LX/LC-EEC	V1					X																			
		V4														X										
		QODC																						X		
	M-SFP-LH/LC-EEC	V1						X																		
		V4															X									
		QODC																							X	
	M-SFP-LH+/LC EEC	V1								X																
		V4																X								
		QODC																								X

Table 8: Description of the characteristic values for uplink ports 1 and 2 / uplink ports 3 and 4 in F/O types

Port type	Built-in transceivers	Version	Characteristic value																							
			1M	1S	1P	1L	1A	1B	1C	1D	4M	4S	4P	4L	4A	4B	4C	4D	5M	5S	5P	5L	5A	5B	5C	5D
100 Mbit/s F/O port	M-FAST SFP-MM/LC EEC	V1	X																							
		V4								X																
		QODC																	X							
	M-FAST SFP-SM/LC EEC	V1	X																							
		V4									X															
		QODC																	X							
	M-FAST SFP-SM+/LC EEC	V1		X																						
		V4									X															
		QODC																		X						
	M-FAST SFP-LH/LC EEC	V1			X																					
		V4										X														
		QODC																			X					
		Explanation ► V1: IP67 plug as per IEC 61076-3-106, variant 1 ► V4: IP67 connector as per IEC 61076-3-106, variant 4 ► Q-ODC®: HUBER + SUHNER																								

Table 8: Description of the characteristic values for uplink ports 1 and 2 / uplink ports 3 and 4 in F/O types

# 1.3 Device view

Above: front of device  
 Below: bottom of device

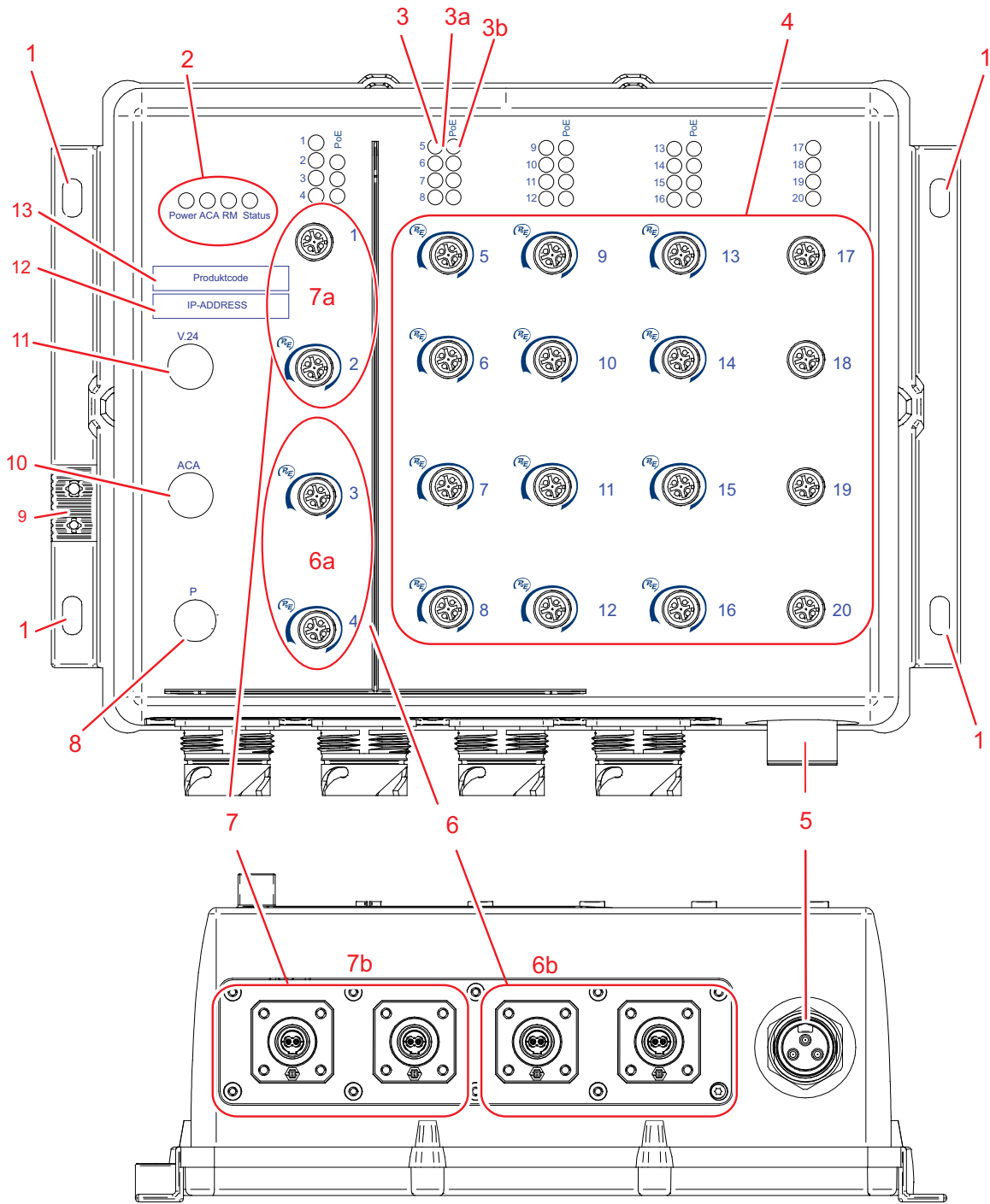


Table 9: Device view

- 1 Hole for mounting
- 2 LED display elements for device status

Table 10: Description of the device view

3	LED display elements for port status:
3a	Link status
3b	Exclusively for PoE(+) ports: PoE status
4	Up to 24 ×: Local ports
	▶ 10/100 Mbit/s twisted pair port ▶ 4-pin, "D"-coded M12 socket of which up to 12 × ports optionally with PoE(+) support
5	On the bottom of the device for specific device variants: Supply voltage connection
	Supply voltage with characteristic value FF 5-pin 7/8" plug
	Supply voltage with the characteristic value M9 3-pin, 7/8" connector
	Supply voltage with the characteristic value N9 4-pin, 7/8" connector
	Supply voltage with characteristic value QQ 4-pin, "T"-coded M12 power plug
	Supply voltage with the characteristic value PP 4-pin, "T"-coded M12 power plug
6	Uplink ports 3 and 4
6a	Twisted-pair ports are located on the front of the device: Alternatively: Data rate characteristic value 2 ▶ 10/100 Mbit/s twisted pair port ▶ 4-pin, "D"-coded M12 socket ▶ Optional: PoE(+) support Alternatively: Data rate characteristic value 3 ▶ 10/100/1000 Mbit/s twisted pair port ▶ 8-pin, "X"-coded M12 socket ▶ Optional: PoE(+) support
6b	F/O ports are located on the bottom of the device: Alternatively: Data rate characteristic value 2 ▶ 100 Mbit/s F/O port ▶ Version: <a href="#">See table 8 on page 20.</a> Alternatively: Data rate characteristic value 3 ▶ 1000 Mbit/s F/O port ▶ Version: <a href="#">See table 8 on page 20.</a>

*Table 10: Description of the device view*

7	Optional: Uplink ports 1 and 2
7a	<p>Twisted-pair ports are located on the front of the device:</p> <p>Alternatively: Data rate characteristic value 2</p> <ul style="list-style-type: none"> <li>▶ 10/100 Mbit/s twisted pair port</li> <li>▶ 4-pin, "D"-coded M12 socket</li> <li>▶ Optionally exclusively on port 2: PoE(+) support</li> </ul> <p>Alternatively: Data rate characteristic value 3</p> <ul style="list-style-type: none"> <li>▶ 10/100/1000 Mbit/s twisted pair port</li> <li>▶ 8-pin, "X"-coded M12 socket</li> <li>▶ Optionally exclusively on port 2: PoE(+) support</li> </ul>
7b	<p>F/O ports are located on the bottom of the device:</p> <p>Alternatively: Data rate characteristic value 2</p> <ul style="list-style-type: none"> <li>▶ 100 Mbit/s F/O port</li> <li>▶ Version: <a href="#">See table 8 on page 20.</a></li> </ul> <p>Alternatively: Data rate characteristic value 3</p> <ul style="list-style-type: none"> <li>▶ 1000 Mbit/s F/O port</li> <li>▶ Version: <a href="#">See table 8 on page 20.</a></li> </ul>
8	<p>alternatively, depending on device variant</p> <p>Supply voltage with the characteristic value BB or HH</p> <ul style="list-style-type: none"> <li>▶ Connection for the power supply including signal contact</li> <li>▶ 5-pin M12 connector</li> </ul> <p>Supply voltage with characteristic value FF, M9, N9, QQ or PP</p> <ul style="list-style-type: none"> <li>▶ Connection for the signal contact</li> <li>▶ 5-pin M12 connector</li> </ul> <p><b>Note:</b> The supply voltage connection is on the bottom of the device.</p>
9	Ground connection
10	5-pin, "A"-coded M12 socket for USB interface
11	4-pin, "A"-coded M12 socket for V.24 interface
12	Label area for IP address of device
13	Product code

*Table 10: Description of the device view*



## **1.4 Power supply**

### **1.4.1 Supply voltage with the characteristic value BB**

A 5-pin M12 plug is available for the redundant supply to the device.  
Further information:

[“Supply voltage with the characteristic value BB” on page 37](#)

### **1.4.2 Supply voltage with the characteristic value FF**

A 5-pin 7/8" plug is available for the redundant supply to the device.  
Further information:

[“Supply voltage with the characteristic value FF” on page 39](#)

These device variants support PoE(+).

Further information:

[“Support of PoE\(+\)” on page 27](#)

### **1.4.3 Supply voltage with the characteristic value HH**

A 5-pin M12 plug is available for the redundant supply to the device.  
Further information:

[“Supply voltage with the characteristic value HH” on page 39](#)

### **1.4.4 Supply voltage with the characteristic value M9**

A 3-pin 7/8" plug is available for the power supply to the device.  
Further information:

[“Supply voltage with the characteristic value M9” on page 40](#)

These device variants optionally support PoE(+).

Further information:

[“Support of PoE\(+\)” on page 27](#)

### **1.4.5 Supply voltage with the characteristic value N9**

A 4-pin 7/8" plug is available for the power supply to the device.  
Further information:

[“Supply voltage with the characteristic value N9” on page 40](#)

These device variants optionally support PoE(+).

Further information:

[“Support of PoE\(+\)” on page 27](#)

### 1.4.6 Supply voltage with the characteristic value QQ

A 4-pin, “T”-coded M12 power plug is available for the redundant supply of the device.

Further information:

[“Supply voltage with the characteristic value QQ” on page 42](#)

These device variants support PoE(+).

Further information:

[“Support of PoE\(+\)” on page 27](#)

### 1.4.7 Supply voltage with the characteristic value PP

A 4-pin, “T”-coded M12 power plug is available for the redundant supply of the device.

These device variants support PoE(+).

Further information:

[“Supply voltage with the characteristic value PP” on page 42](#)

## 1.5 Ethernet ports

You have the option of choosing various media to connect to the end devices and other network components:

- ▶ Multimode optical fiber
- ▶ Singlemode optical fiber
- ▶ Twisted pair cable

You find information on pin assignments for making patch cables here:

[“Pin assignments” on page 30](#)

### 1.5.1 Twisted pair

#### ■ 10/100 Mbit/s twisted pair port

**Note:** Some of these ports also support PoE(+).

See [“Support of PoE\(+\)” on page 27](#).

This port is a 4-pin, “D”-coded M12 socket.

The 10/100 Mbit/s twisted pair port allows you to connect network components according to the IEEE 802.3 10BASE-T/100BASE-TX standard.

This port supports:

- ▶ Autonegotiation
- ▶ Autopolarity
- ▶ Autocrossing (if autonegotiation is activated)

- ▶ 100 Mbit/s half-duplex mode, 100 Mbit/s full duplex mode
- ▶ 10 Mbit/s half-duplex mode, 10 Mbit/s full duplex mode

Delivery state: Autonegotiation activated

The socket housing is electrically connected with the device housing.

## ■ 10/100/1000 Mbit/s twisted pair port

**Note:** Some of these ports also support PoE(+).

See “Support of PoE(+)” on page 27.

This port is an 8-pin, “X”-coded M12 socket.

The 10/100/1000 Mbit/s twisted pair port allows you to connect network components according to the IEEE 802.3 10BASE-T/100BASE-TX/1000BASE-T standard.

This port supports:

- ▶ Autocrossing
- ▶ Autonegotiation
- ▶ Autopolarity
- ▶ 10 Mbit/s half-duplex mode, 10 Mbit/s full duplex mode
- ▶ 100 Mbit/s half-duplex mode, 100 Mbit/s full duplex mode
- ▶ 1000 Mbit/s full duplex

Delivery state: Autonegotiation activated

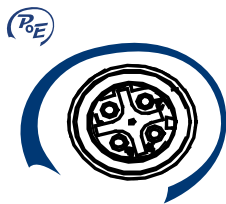
The socket housing is electrically connected with the device housing.

### 1.5.2 Support of PoE(+)

The device variants featuring hardware type characteristic value 4 support Power over Ethernet (PoE) and Power over Ethernet Plus (PoE+).

With the presence of the PoE power supply, a separate power supply for the connected device is unnecessary.

You can identify PoE(+) ports by the following symbol.



The individual ports (joint PoE voltage) are not electrically insulated from each other.

Maximum power available to PoE end devices in total:

60 W

**Note:** For device variants with supply voltage characteristic value PP, use an external PoE power supply unit with 150 W. This means that the maximum output available to all PoE end devices is in total 120 W.

Connect only PoE-supplier devices whose data connections are located in the interior of the building and are specified as SELV circuits.

The PoE support complies with the following technical standards:

Technical standard	Description	
IEEE 802.3af	Brief description	PoE
	Classes	max. Powered Device (PD) class 0 (15.4 W)
IEEE 802.3at	Brief description	PoE+
	Classes	max. Powered Device (PD) class 4 (30 W)

Table 11: PoE support: technical standards

In accordance with IEEE 802.3af and IEEE 802.3at:

- ▶ Endpoint PSE
- ▶ Alternative A.

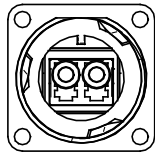
### ■ 10/100 Mbit/s PoE(+) port

The 10/100 Mbit/s PoE(+) port allows you to connect network components as a powered device (PD) according to standards IEEE 802.3 10BASE-T/100BASE-TX and IEEE 802.3af/at.

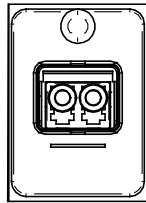
### ■ 10/100/1000 Mbit/s PoE(+) port

The 10/100/1000 Mbit/s PoE(+) port allows you to connect network components as a powered device (PD) according to standards IEEE 802.3 10BASE-T/100BASE-TX/1000BASE-T and IEEE 802.3af/at.

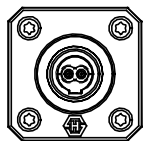
### 1.5.3 Optical fiber



V1: IP67 plug as per IEC 61076-3-106, variant 1



V4: IP67 connector as per IEC 61076-3-106, variant 4



Q-ODC®: HUBER + SUHNER

---

*Table 12: Versions of F/O ports in the Octopus II devices*

The product code tells you which properties your device has.  
See [“Device name and product code”](#) on page 15.

#### ■ **100 Mbit/s F/O port**

The 100 Mbit/s F/O port allows you to connect network components according to the IEEE 802.3 100BASE-FX standard.

This port supports:

- ▶ Full duplex mode

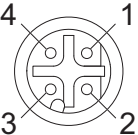
#### ■ **1000 Mbit/s F/O port**

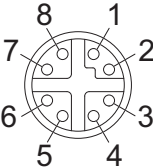
The 1000 Mbit/s F/O port offers you the ability to connect network components according to the IEEE 802.3 1000BASE-SX/1000BASE-LX standard.

This port supports:

- ▶ Full duplex mode

## 1.5.4 Pin assignments

M12 4-pin (“D”-coded)		Pin	Data	PoE
	1	TX+	Positive $V_{PSE}$	
	2	RX+	Negative $V_{PSE}$	
	3	TX-	Positive $V_{PSE}$	
	4	RX-	Negative $V_{PSE}$	

M12 8-pin (“X”-coded)		Pin	10/100 Mbit/s	1000 Mbit/s	PoE
	1	RX+	BI_DB+	Negative $V_{PSE}$	
	2	RX-	BI_DB-	Negative $V_{PSE}$	
	3	TX+	BI_DA+	Positive $V_{PSE}$	
	4	TX-	BI_DA-	Positive $V_{PSE}$	
	5	—	BI_DC+	—	
	6	—	BI_DC-	—	
	7	—	BI_DD-	—	
	8	—	BI_DD+	—	

## 1.6 Display elements

After the supply voltage is set up, the Software starts and initializes the device. Afterwards, the device performs a self-test. During this process, various LEDs light up.

### 1.6.1 Device state

These LEDs provide information about conditions which affect the operation of the whole device.



LED	Display	Color	Activity	Meaning
Power	Supply voltage	—	none	Supply voltage is too low
		yellow	lights up	Device variants with redundant power supply: Supply voltage 1 <b>or</b> 2 is on
			flashes 4 times a period	Software update is running. Maintain the power supply.
		green	lights up	Device variants with redundant power supply: Supply voltage 1 <b>and</b> 2 is on Device variants with single power supply: Supply voltage is on
ACA	ACA21-M12/ ACA22-M12 storage medium (USB interface)	—	none	ACA storage medium not connected
		green	lights up	ACA storage medium connected
			flashes 3 times a period	Device writes to/reads from the storage medium
	yellow	lights up	ACA storage medium inoperative	
RM	Ring Manager	—	none	No redundancy configured
		green	lights up	Redundancy exists
			flashes 1 time a period	Device is reporting an incorrect configuration of the RM function
	yellow	lights up	No redundancy exists	
Status	Device Status	—	none	Device is starting and/or is not ready for operation.
		green	lights up	Device is ready for operation. Characteristics can be configured
		red	lights up	Device is ready for operation. Device has detected at least one error in the monitoring results
			flashes 1 time a period	The boot parameters used when the device has been started differ from the boot parameters saved. Start the device again.
	flashes 4 times a period	Device has detected a multiple IP address		

## 1.6.2 Port status

These LEDs provide port-related information.

### ■ Link state

These LEDs are identified with the number of the related port.

LED	Display	Color	Activity	Meaning
L/D	Link status	—	none	Device detects an invalid or missing link
		green	lights up	Device detects a valid link
			flashes 1 time a period	Port is switched to stand-by
			flashes 3 times a period	Port is switched off
		yellow	lights up	Device detects a data rate that is <b>not</b> supported
			flashing	Device is transmitting and/or receiving data
			flashes 1 time a period	Device detects at least one unauthorized MAC address (Port Security Violation)

### ■ PoE status

Only PoE ports have these LEDs. The LED is on the right of the respective link state LED.

LED	Display	Color	Activity	Meaning
PoE	PoE status	—	none	No powered device connected
		green	lights up	Powered device is supplied with PoE voltage.
		yellow	flashes 1 time a period	Output budget has been exceeded Device has detected a connected powered device
			flashes 3 times a period	PoE administrator status deactivated

## 1.7 Management interfaces

### 1.7.1 USB interface

This interface offers you the ability to connect the storage medium AutoConfiguration Adapter ACA21-M12/ACA22-M12. This storage medium is used for saving/loading the configuration and diagnostic functions, and for loading the software.

This interface is a 5-pin, “A”-coded M12 socket with shielding.

Only connect the ACA21-M12/ACA22-M12 storage medium. You can obtain this as accessory: [See “Accessories” on page 63.](#)



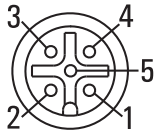
	Pin	Function
	1	U <sub>in</sub> 5 V
	2	N.C. Not used
	3	D- Data -
	4	GND Ground (0 V)
	5	D+ Data +

Table 13: Pin assignment of the USB interface, 5-pin, “A”-coded M12 socket

### 1.7.2 V.24 interface (external management)

The V.24 interface is an M12 socket.

A serial interface is provided on the V.24 interface for the local connection of an external management station (VT100 terminal or PC with corresponding terminal emulation). This enables you to set up a connection to the Command Line Interface (CLI) and to the system monitor.

VT100 terminal settings	
Speed	9600 Baud
Data	8 bit
Stopbit	1 bit
Handshake	off
Parity	none

The socket housing is electrically connected to the housing of the device.

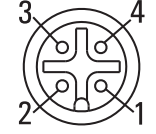
Figure	Pin	Function
	1	TX. Transmit Data
	2	RX Receive Data
	3	N.C. Not used
	4	GND Ground

Table 14: Pin assignment of the V.24 interface (M12 socket)

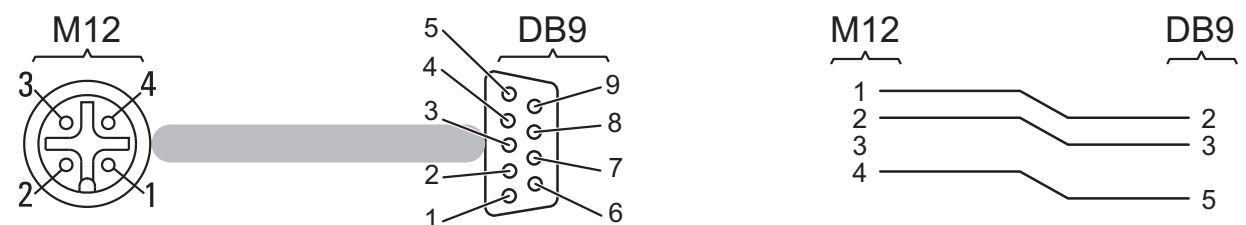


Figure 1: Terminal cable for connecting an external Management Station

The Terminal cable is available as an accessory.

You will find a description of the V.24 interface in the “User Manual Basic Configuration” document.

You can find further information on the Internet on the Hirschmann product pages under

[www.hirschmann.com](http://www.hirschmann.com)

## **1.8 Signal contact**

The signal contact is a potential-free relay contact. The signal contact is open when the device is not connected to a power supply.

The signal contact allows you to control external devices or monitor device functions.

In the configuration, you specify how the device uses the signal contact.

You will find detailed information on possible applications and the configuration of the signal contact in the software user documentation. You will find the software user documentation as PDF files on the Internet at

<https://www.doc.hirschmann.com>

## 2 Installation

The devices have been developed for practical application in a harsh industrial environment.

On delivery, the device is ready for operation.

Perform the following steps to install and configure the device:

- ▶ [Checking the package contents](#)
- ▶ [Installing and grounding the device](#)
- ▶ [Connecting the power supply and the signal contact lines](#)
- ▶ [Operating the device](#)
- ▶ [Connecting data cables](#)
- ▶ [Filling out the inscription label](#)
- ▶ [Making basic settings](#)

### 2.1 Checking the package contents

Proceed as follows:

- Check whether the package includes all items named in the section [“Scope of delivery” on page 61](#).
- Check the individual parts for transport damage.

### 2.2 Installing and grounding the device

#### 2.2.1 Installing the device

## **WARNING**

### **ELECTRIC SHOCK**

Exclusively for device variants featuring supply voltage with characteristic value M9 or N9:

Install this device solely in a switch cabinet or in an operating site with restricted access, to which maintenance staff have exclusive access.

**Failure to follow this instruction can result in death, serious injury, or equipment damage.**

To protect the exposed uninstalled contacts of the components from dirt, connect the individual system components in a dry and clean working area.

**Note:** Exclusively for device variants featuring temperature range characteristic value T:

Mount the device on a 1.62 sq ft (0.15 m<sup>2</sup>) large, 0.09 in (2 mm) thick metal plate to which you do not connect any other heat source. Otherwise the maximum ambient temperature is reduced by 5 K.

See “General technical data” on page 50.

- Prepare the drill holes at the installation point.
- Mount the device on a level surface with 4 M5 screws.
- To preserve the suitability of your device for IP65/67, proceed as follows:
  - Remove the provided transport protection caps and the transport protection screws from the device.
  - Seal unused sockets and plugs with your desired type of protection screws which you can order separately.

### 2.2.2 Grounding the device

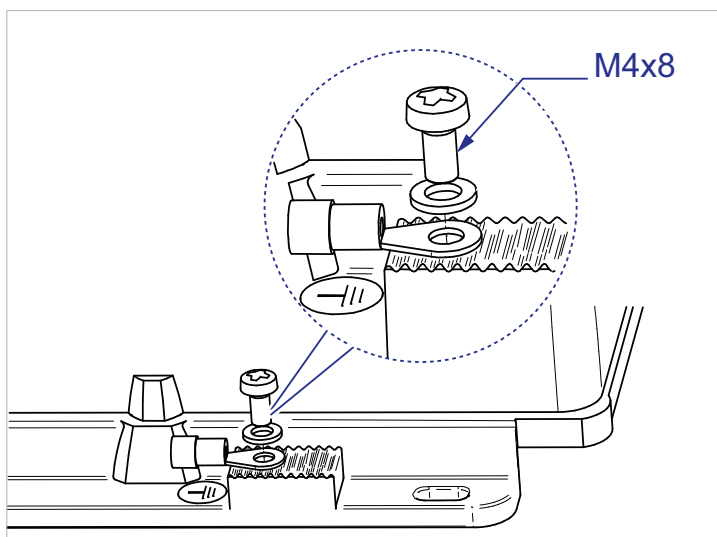
Grounding the device is by means of a separate ground connection on the device.

The overall shield of a connected shielded twisted pair cable is connected to the ground connection on the metal housing as a conductor.

The device variants have a connection for protective grounding.

**Note:** Use toothed washers to ensure good electrical conductivity at the connection.

- Ground the device via the provided M4 screw.



## 2.3 Connecting the ferrite

**Note:** Exclusively for device variants with characteristic value hardware type 0 (Standard) in connection with supply voltage characteristic values M9, N9 or for device variants with the supply voltage characteristic value PP: To adhere to EMC conformity, you connect the ferrite supplied to the voltage input via the power supply cable.

**Note:** To open the ferrite use the key supplied.

- Insert the power supply cable through the ferrite 1 times.
- Position the ferrite as close as possible to the voltage input (max. distance 19.7 in (50 cm)).
- Lock the ferrite.

## 2.4 Connecting the power supply and the signal contact lines

### **WARNING**

#### **ELECTRIC SHOCK**

Before connecting the electrical wires, **always** verify that the requirements listed are complied with.

[See “Requirements for connecting electrical wires” on page 6.](#)

**Failure to follow this instruction can result in death, serious injury, or equipment damage.**

### 2.4.1 Supply voltage with the characteristic value **BB**

A 5-pin M12 plug is available for the redundant supply to the device.

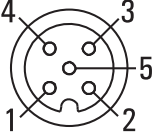
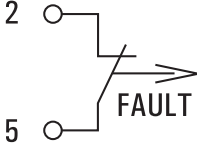
You find the prescribed tightening torque in chapter:

[See 50 “Technical data”.](#)

The supply voltage is connected to the device casing through protective elements exclusively.

You have the option of supplying the supply voltage redundantly, without load distribution.

With a non-redundant supply of the supply voltage, the device reports the loss of a supply voltage. You can prevent this message by changing the configuration in the Management.

Type and specification of the supply voltage	Pin assignment		
Rated voltage 24 V DC			1 Plus terminal of supply voltage 1
Voltage range incl. maximum tolerances 16.8 V DC ... 32 V DC			2 Signal contact
			3 Minus terminal of supply voltages 1 and 2
			4 Plus terminal of supply voltage 2
			5 Signal contact

- Connect the electrical wires to the socket according to the pin assignment.

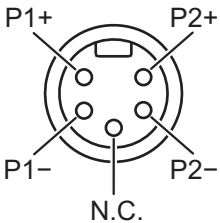
## 2.4.2 Supply voltage with the characteristic value FF

A 5-pin 7/8" plug is available for the redundant supply to the device.  
You find the prescribed tightening torque in chapter:  
[See 50 "Technical data"](#).

The supply voltage is connected to the device casing through protective elements exclusively.

You have the option of supplying the supply voltage redundantly, without load distribution.

With a non-redundant supply of the supply voltage, the device reports the loss of a supply voltage. You can prevent this message by changing the configuration in the Management.

Type and specification of the supply voltage	Pin assignment		
Rated voltage range 24 V DC ... 48 V DC		P1+	Plus terminal of supply voltage 1
Voltage range incl. maximum tolerances 16.8 V DC ... 60 V DC		P1-	Minus terminal of supply voltage 1
		N.C.	—
		P2-	Minus terminal of supply voltage 2
		P2+	Plus terminal of supply voltage 2

- Connect the electrical wires to the socket according to the pin assignment.

## 2.4.3 Supply voltage with the characteristic value HH

A 5-pin M12 plug is available for the redundant supply to the device.  
You find the prescribed tightening torque in chapter:  
[See "Technical data" on page 50.](#)

The supply voltage is connected to the device casing through protective elements exclusively.

You have the option of supplying the supply voltage redundantly, without load distribution.

With a non-redundant supply of the supply voltage, the device reports the loss of a supply voltage. You can prevent this message by changing the configuration in the Management.

Type and specification of the supply voltage	Pin assignment	
Rated voltage 36 V DC ... 48 V DC		1 Plus terminal of supply voltage 1
Voltage range incl. maximum tolerances 25.2 V DC ... 60 V DC		2 Signal contact
		3 Minus terminal of supply voltages 1 and 2
		4 Plus terminal of supply voltage 2
		5 Signal contact

- Connect the electrical wires to the socket according to the pin assignment.

#### 2.4.4 Supply voltage with the characteristic value M9

A 3-pin 7/8" plug is available for the power supply to the device.  
You find the prescribed tightening torque in chapter:  
[See "Technical data" on page 50.](#)

The supply voltage is connected to the device casing through protective elements exclusively.

Type and specification of the supply voltage	Pin assignment	
Rated voltage range 110 V AC ... 230 V AC, 50 Hz ... 60 Hz		L Outer conductor
Voltage range including maximum tolerances		PE Protective conductor
88 V AC ... 265 V AC, 47 Hz ... 63 Hz		N Neutral conductor

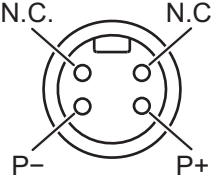
- Connect the electrical wires to the socket according to the pin assignment.

#### 2.4.5 Supply voltage with the characteristic value N9

A 4-pin 7/8" plug is available for the power supply to the device.  
You find the prescribed tightening torque in chapter:  
[See "Technical data" on page 50.](#)

The supply voltage is connected to the device casing through protective elements exclusively.



Type and specification of the supply voltage	Pin assignment	
Rated voltage 72 V DC ... 110 V DC		N.C. —
Voltage range incl. maximum tolerances		P+ Plus terminal of the supply voltage
50.4 V DC ... 138 V DC		P- Minus terminal of the supply voltage

- Connect the electrical wires to the socket according to the pin assignment.

## 2.4.6 Supply voltage with the characteristic value QQ

A 4-pin, “T”-coded M12 power plug is available for the redundant supply of the device.

You find the prescribed tightening torque in chapter:

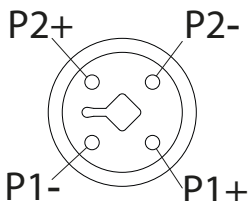
[See “Technical data” on page 50.](#)

**Note:** For applications in trains only use shielded power supply cables if the German Regelung Nr. EMV 06 (Regulation No. EMC 06) for electromagnetic compatibility of railway vehicles with railway radio services is to be applied. The provided M12 Power plug allows you to connect shielded power supply cables.

The supply voltage is connected to the device casing through protective elements exclusively.

You have the option of supplying the supply voltage redundantly, without load distribution.

With a non-redundant supply of the supply voltage, the device reports the loss of a supply voltage. You can prevent this message by changing the configuration in the Management.

Type and specification of the supply voltage	Pin assignment	
Rated voltage range 24 V DC ... 48 V DC		
Voltage range incl. maximum tolerances 16.8 V DC ... 60 V DC		
		P1+ Plus terminal of supply voltage 1
		P1- Minus terminal of supply voltage 1
		P2- Minus terminal of supply voltage 2
	P2+ Plus terminal of supply voltage 2	

Connect the electrical wires to the socket according to the pin assignment.

## 2.4.7 Supply voltage with the characteristic value PP

**Note:** Exclusively use a PoE power supply unit with galvanic isolation. Hirschmann has tested the power supply unit PC150/110V/54V and recommends its use. You find the order number for the power supply unit, which is available as accessory, under:

[“Accessories” on page 63](#)

A 4-pin, “T”-coded M12 power plug is available for the redundant supply of the device.

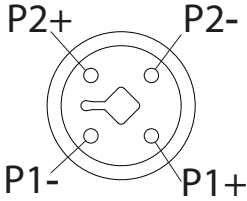
You find the prescribed tightening torque in chapter:

[See “Technical data” on page 50.](#)

The supply voltage is connected to the device casing through protective elements exclusively.

You have the option of supplying the supply voltage redundantly, without load distribution.

With a non-redundant supply of the supply voltage, the device reports the loss of a supply voltage. You can prevent this message by changing the configuration in the Management.

Type and specification of the supply voltage	Pin assignment								
<p><b>when using PoE:</b>            Rated voltage            48 V DC            Voltage range incl. maximum tolerances            47 V DC ... 57 V DC</p> <p><b>when using PoE+:</b>            Rated voltage            54 V DC            Voltage range incl. maximum tolerances            53 V DC ... 57 V DC</p> <p><b>without using PoE or PoE+:</b>            Rated voltage range            24 V DC ... 48 V DC            Voltage range incl. maximum tolerances            19 V DC ... 60 V DC</p>	<div style="display: flex; align-items: center; justify-content: center;">  <table border="1" style="margin-left: 20px;"> <tr> <td data-bbox="973 526 1036 564">P1+</td> <td data-bbox="1078 526 1381 592">Plus terminal of supply voltage 1</td> </tr> <tr> <td data-bbox="973 599 1036 637">P1-</td> <td data-bbox="1078 599 1404 665">Minus terminal of supply voltage 1</td> </tr> <tr> <td data-bbox="973 672 1036 710">P2+</td> <td data-bbox="1078 672 1381 738">Plus terminal of supply voltage 2</td> </tr> <tr> <td data-bbox="973 745 1036 783">P2-</td> <td data-bbox="1078 745 1404 811">Minus terminal of supply voltage 2</td> </tr> </table> </div>	P1+	Plus terminal of supply voltage 1	P1-	Minus terminal of supply voltage 1	P2+	Plus terminal of supply voltage 2	P2-	Minus terminal of supply voltage 2
P1+	Plus terminal of supply voltage 1								
P1-	Minus terminal of supply voltage 1								
P2+	Plus terminal of supply voltage 2								
P2-	Minus terminal of supply voltage 2								

- Connect the electrical wires to the socket according to the pin assignment.

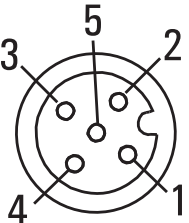
## 2.4.8 Signal contact

A 5-pin M12 plug is available as a signal contact.

You find the prescribed tightening torque in chapter:

[See “Technical data” on page 50.](#)

Depending on device variant, the signal contact lines are laid in the power supply plug or in a separate plug.

	Pin assignments for device variants:	Pin assignments for device variants:
	<ul style="list-style-type: none"> <li>▶ Supply voltage with the characteristic value BB</li> <li>▶ Supply voltage with the characteristic value HH</li> </ul>	<ul style="list-style-type: none"> <li>▶ Supply voltage with characteristic value FF</li> <li>▶ Supply voltage with the characteristic value M9</li> <li>▶ Supply voltage with the characteristic value N9</li> <li>▶ Supply voltage with characteristic value QQ</li> <li>▶ Supply voltage with the characteristic value PP</li> </ul>
	1 Plus terminal of supply voltage 1	N.C.
	2 Signal contact	Signal contact
	3 Minus terminal of supply voltages 1 and 2	N.C.
	4 Plus terminal of supply voltage 2	N.C.
	5 Signal contact	Signal contact

## 2.5 Operating the device

### **WARNING**

#### **ELECTRIC SHOCK**

Before connecting the electrical wires, **always** verify that the requirements listed are complied with.

[See “Requirements for connecting electrical wires” on page 6.](#)

**Failure to follow this instruction can result in death, serious injury, or equipment damage.**

By connecting the supply voltage via a connector, you start the operation of the device.

Proceed as follows:

- Connect the power supply cable.
- Enable the supply voltage.

## **2.6 Connecting data cables**

Note the following general recommendations for data cable connections in environments with high electrical interference levels:

- Keep the length of the data cables as short as possible.
  - Use optical data cables for the data transmission between the buildings.
  - When using copper cables, provide a sufficient separation between the power supply cables and the data cables. Ideally, install the cables in separate cable channels.
  - Verify that power supply cables and data cables do not run parallel over longer distances. If reducing the inductive coupling is necessary, verify that the power supply cables and data cables cross at a 90° angle.
  - Use SF/UTP cables as per ISO/IEC 11801:2002.
- 
- Connect the data cables according to your requirements.

Further information:

[“Ethernet ports” on page 26](#)

## **2.7 Filling out the inscription label**

The information field for the IP address helps you identify your device.

### 3 Making basic settings

The IP parameters must be entered when the device is installed for the first time. The device provides the following options for configuring IP addresses:

- ▶ Input via the V.24 interface
- ▶ Input via the HiView or Industrial HiVision application. You find further information about the applications HiView or Industrial HiVision on the Internet at the Hirschmann product pages:

#### **HiView**

<http://www.hirschmann.com/en/QR/INET-HiView>

#### **Industrial HiVision**

<http://www.hirschmann.com/en/QR/INET-Industrial-HiVision>

- ▶ Configuration via BOOTP
- ▶ Configuration via DHCP (Option 82)
- ▶ AutoConfiguration Adapter

#### ■ **Default settings**

- ▶ IP address: The device looks for the IP address using DHCP
- ▶ Management password:
  - user, password: public (read only)
  - admin, password: private (read/write)
- ▶ V.24 data rate: 9600 Baud
- ▶ Ethernet ports: link status is not evaluated (signal contact)
- ▶ Optical ports: Full duplex
- TP ports: Autonegotiation
- ▶ RSTP (Rapid Spanning Tree) activated

## 4 Monitoring the ambient air temperature

Operate the device below the specified maximum ambient air temperature exclusively.

See [“General technical data” on page 50](#).

The ambient air temperature is the temperature of the air at a distance of 2 in (5 cm) from the device. It depends on the installation conditions of the device, for example the distance from other devices or other objects, and the output of neighboring devices.

The temperature displayed in the CLI and the GUI is the internal temperature of the device. It is higher than the ambient air temperature. The maximum internal temperature of the device named in the technical data is a guideline that indicates to you that the maximum ambient air temperature has possibly been exceeded.

## 5 Maintenance and service

- ▶ When designing this device, Hirschmann largely avoided using high-wear parts. The parts subject to wear and tear are dimensioned to last longer than the lifetime of the product when it is operated normally. Operate this device according to the specifications.
- ▶ Relays are subject to natural wear. This wear depends on the frequency of the switching operations. Check the resistance of the closed relay contacts and the switching function depending on the frequency of the switching operations.
- ▶ Hirschmann is continually working on improving and developing their software. Check regularly whether there is an updated version of the software that provides you with additional benefits. You find information and software downloads on the Hirschmann product pages on the Internet (<http://www.hirschmann.com>).

**Note:** You find information on settling complaints on the Internet at <http://www.beldensolutions.com/en/Service/Repairs/index.phtml>.



## 6 Disassembly



### **WARNING**

#### **ELECTRIC SHOCK**

Disconnect the grounding only after disconnecting all other cables.

**Failure to follow this instruction can result in death, serious injury, or equipment damage.**

- Disable the supply voltage.
- Disconnect the data cables.
- Disconnect the power supply cables and signal lines.
- Disconnect the grounding.

# 7 Technical data

## ■ General technical data

Dimensions W × H × D	Octopus II	See "Dimension drawings" on page 54.	
Weight	Devices with 24 or 28 Fast Ethernet ports	approx. 4.3 kg	
	Other devices	approx. 7.7 lb (3.5 kg)	
Mounting	Flat surface mounting		
	Screw type	M5	
Power supply Supply voltage with the characteristic value BB	Rated voltage	24 V DC	
	Voltage range incl. maximum tolerances	16.8 V DC ... 32 V DC	
	Connection type	5-pin M12 connector	
		Tightening torque	5.3 lb-in (0.6 Nm)
	Power loss buffer	>10 ms at 20.4 V DC	
	Overload current protection on the device	Non-replaceable fuse	
	Back-up fuse for each voltage input	Nominal rating:	2 A
		Characteristic:	slow blow
Peak inrush current	<2 A		
Power supply Supply voltage with the characteristic value HH	Rated voltage range	36 V DC ... 48 V DC	
	Voltage range incl. maximum tolerances	25.2 V DC ... 60 V DC	
	Connection type	5-pin M12 connector	
		Tightening torque	5.3 lb-in (0.6 Nm)
	Power loss buffer	> 10 ms at 30.6 V DC	
	Overload current protection on the device	Non-replaceable fuse	
	Back-up fuse	Nominal rating:	2 A
		Characteristic:	slow blow
Peak inrush current	<2 A		
Power supply Supply voltage with characteristic value FF, QQ	Rated voltage range	24 V DC ... 48 V DC	
	Voltage range incl. maximum tolerances	16.8 V DC ... 60 V DC	
	Max. PoE power	60 W	
	Connection type	<b>Characteristic value FF</b>	
		5-pin 7/8" plug	
		Tightening torque	22 lb-in (2.5 Nm)
		<b>Characteristic value QQ</b>	
	Connection type	4-pin, "T"-coded M12 power plug	
		Tightening torque	5.3 lb-in (0.6 Nm)
		Power loss buffer	>10 ms at 20.4 V DC
		Overload current protection on the device	Non-replaceable fuse
	Back-up fuse	Nominal rating:	10 A ... 20 A
Characteristic:		slow blow	
Peak inrush current	<7 A		

Power supply Supply voltage with the characteristic value PP	Rated voltage	When using PoE: 48 V DC
		When using PoE+: 54 V DC
		Without using PoE: 24 V DC ... 48 V DC or PoE+:
	Voltage range incl. maximum tolerances	When using PoE: 47 V DC ... 57 V DC
	Max. PoE power	120 W <sup>a</sup>
	Connection type	4-pin, "T"-coded M12 power plug
		Tightening torque 5.3 lb-in (0.6 Nm)
	Power loss buffer	>10 ms at 20.4 V DC
	Overload current protection on the device	Non-replaceable fuse
	Back-up fuse	Nominal rating: 6.3 A Characteristic: slow blow
Peak inrush current	<5 A	
Power supply Supply voltage with the characteristic value M9	Rated voltage range	110 V AC ... 230 V AC, 50 Hz ... 60 Hz
	Voltage range including maximum tolerances	88 V AC ... 265 V AC, 47 Hz ... 63 Hz
	Max. PoE power	60 W
	Connection type	3-pin, 7/8" connector
		Tightening torque 22 lb-in (2.5 Nm)
	Power loss buffer	>10 ms at 93.5 V AC
	Overload current protection on the device	Non-replaceable fuse
	Back-up fuse OS20/OS30	Nominal rating: 1 A ... 20 A Characteristic: slow blow
	Back-up fuse OS24/OS34	Nominal rating: 4 A ... 20 A Characteristic: slow blow
	Peak inrush current OS20/OS30	<3.5 A
Peak inrush current OS24/OS34	<7 A	
Power supply Supply voltage with the characteristic value N9	Rated voltage range	72 V DC ... 110 V DC
	Voltage range incl. maximum tolerances	50.4 V DC ... 138 V DC
	Max. PoE power	60 W
	Connection type	4-pin, 7/8" connector
		Tightening torque 22 lb-in (2.5 Nm)
	Power loss buffer	>10 ms at 61 V DC
	Overload current protection on the device	Non-replaceable fuse
	Back-up fuse OS20/OS30	Nominal rating: 1 A ... 20 A Characteristic: slow blow
	Back-up fuse OS24/OS34	Nominal rating: 4 A ... 20 A Characteristic: slow blow
	Peak inrush current OS20/OS30	<3.5 A
Peak inrush current OS24/OS34	<7 A	

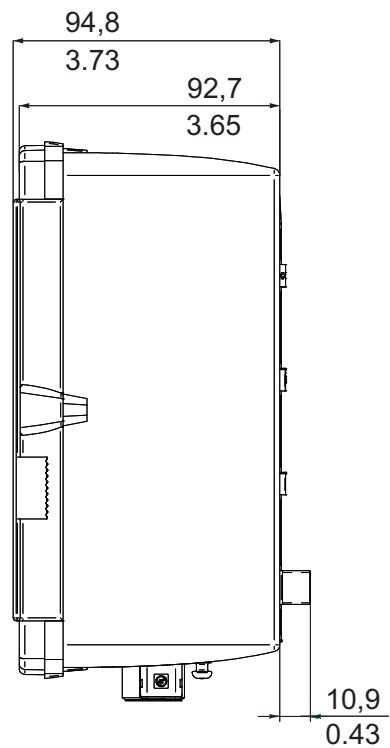
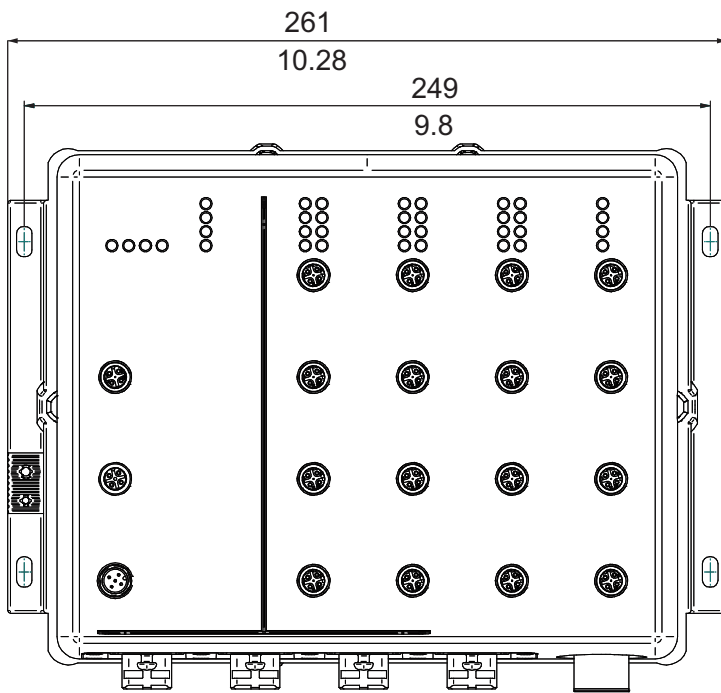
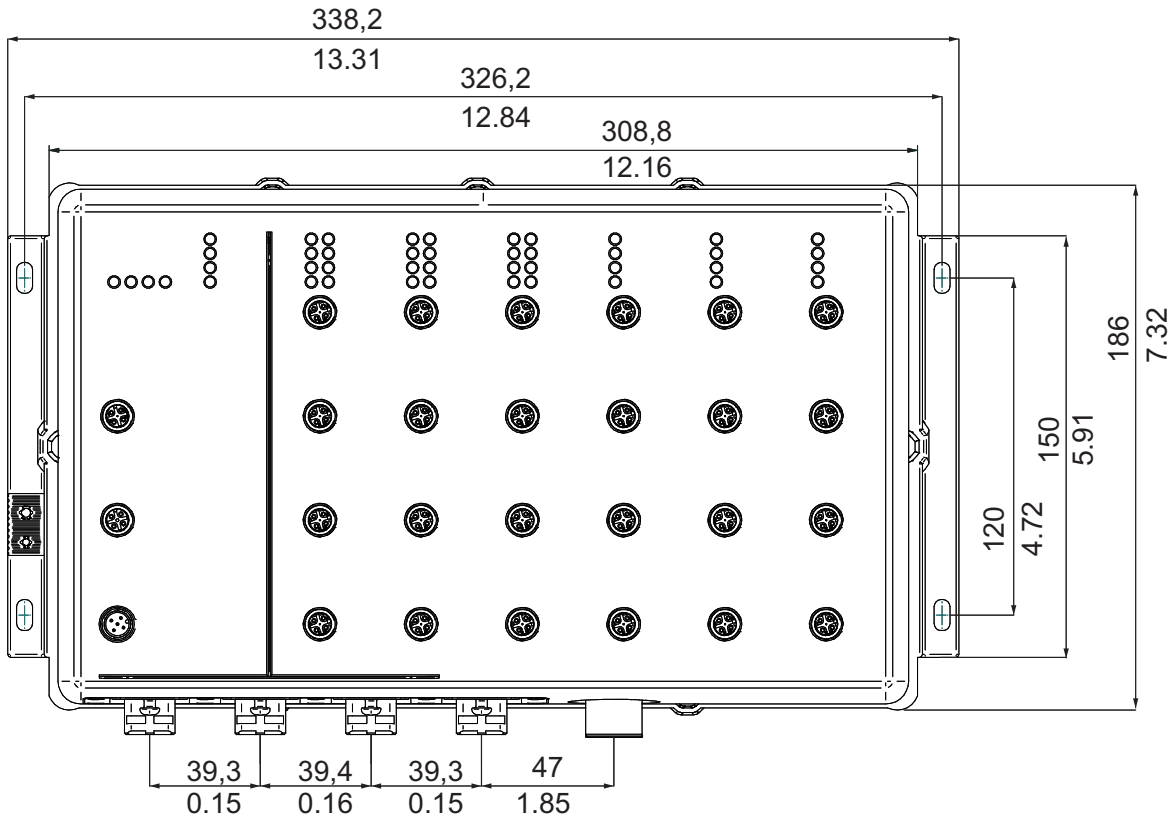
Signal contact	Switching current	max. 1 A
	Switching voltage	max. 60 V DC max. 30 V AC
	Connection type	5-pin M12 connector
Climatic conditions during operation	Tightening torque	5.3 lb-in (0.6 Nm)
	Minimum clearance around the device	Top and bottom sides of device: 2 in (5 cm) Left and right sides of device: 1.97 in (5 cm)
	Ambient air temperature <sup>c</sup>	Derating <sup>b</sup> : 5 K at the following clearance: Top and bottom sides of device: 0 in Left and right device side: 0 in (0 cm)
		Devices with operating temperature characteristic value V (standard): -40 °F ... +140 °F (-40 °C ... +60 °C)
	Devices with operating temperature characteristic value T (extended): -40 °F ... +158 °F (-40 °C ... +70 °C)	
	Derating <sup>a</sup> : Exclusively for device variants featuring temperature range characteristic value T: ► Mount the device on a 1.62 sq ft (0.15 m <sup>2</sup> ) large, 0.09 in (2 mm) thick metal plate to which you do not connect any other heat source. Otherwise the maximum ambient temperature is reduced by 5 K. Exclusively applies to device variants with temperature range characteristic value V or T: ► When using more than 30 W PoE power, the maximum ambient temperature is reduced by 10 K. <sup>d</sup>	
	Maximum inner temperature of device (guideline)	Devices with operating temperature characteristic value V (standard): 90 °C
		Devices with operating temperature characteristic value T (extended): 95 °C
	Humidity	5 % ... 100 % (also in condensing atmospheres) <sup>e</sup>
	Air pressure	min. 700 hPa (+9842 ft; +3000 m) max. 1060 hPa (-1312 ft; -400 m)

Climatic conditions during storage	Ambient air temperature <sup>b</sup>	-40 °F ... +185 °F (-40 °C ... +85 °C)
	Humidity	5 % ... 100 % (also in condensing atmospheres) <sup>f</sup>
	Air pressure	min. 700 hPa (+9842 ft; +3000 m) max. 1060 hPa (-1312 ft; -400 m)
Pollution degree		2
Protection classes	Laser protection	Class 1 in compliance with IEC 60825-1
	Degree of protection	IP65/67 <sup>g</sup>

- a. Exclusively applies when using an external power supply unit with 150 W.
- b. Reduction of the maximum permitted ambient air temperature under specific conditions
- c. Temperature of the ambient air at a distance of 2 in (5 cm) from the device
- d. Exception: Device variants with supply voltage characteristic value PP.
- e. Remove the provided transport protection caps and the transport protection screws from the device. Seal unused sockets and plugs with your desired type of protection screws which you can order separately.
- f. Remove the provided transport protection caps and the transport protection screws from the device. Seal unused sockets and plugs with your desired type of protection screws which you can order separately.
- g. To preserve the suitability of your device for IP65/67, proceed as follows: Remove all provided transport protection caps and transport protection screws. Seal unused sockets and plugs with your desired type of protection screws which you can order separately.

# Dimension drawings

mm  
inch



## ■ **EMC and immunity**

**Note:** You will find detailed information on the certificates and declarations applying to your device in a separate overview.  
[See table 7 on page 19.](#)

EMC interference emission		Standard applications	Navy applications	Railway applications (trackside)	Railway applications (in vehicles)	Motor vehicle applications
<b>Radiated emission</b>						
EN 55032		Class A	Class A	Class A	Class A	Class A
DNV GL Guidelines		—	EMC 1	—	—	—
FCC 47 CFR Part 15		Class A	Class A	Class A	Class A	Class A
EN 61000-6-4		Fulfilled	Fulfilled	Fulfilled	Fulfilled	Fulfilled
<b>Conducted emission</b>						
EN 55032	DC supply connection	Class A	Class A	Class A	Class A	Class A
DNV GL Guidelines	DC supply connection	—	EMC 1	—	—	—
FCC 47 CFR Part 15	DC supply connection	Class A	Class A	Class A	Class A	Class A
EN 61000-6-4	DC supply connection	Fulfilled	Fulfilled	Fulfilled	Fulfilled	Fulfilled
EN 55032	Telecommunication connections	Class A	Class A	Class A	Class A	Class A
EN 61000-6-4	Telecommunication connections	Fulfilled	Fulfilled	Fulfilled	Fulfilled	Fulfilled



<b>EMC interference immunity</b>		<b>Standard applications</b>	<b>Navy applications</b>	<b>Railway applications (trackside)</b>	<b>Railway applications (in vehicles)</b>	<b>Motor vehicle applications</b>
<b>Electrostatic discharge</b>						
EN 61000-4-2 IEEE C37.90.3	Contact discharge	±4 kV	±6 kV	±6 kV	±6 kV	±4 kV
EN 61000-4-2 IEEE C37.90.3	Air discharge	±8 kV	±8 kV	±8 kV	±8 kV	±8 kV
<b>Electromagnetic field</b>						
EN 61000-4-3	80 MHz ... 3000 MHz	max. 10 V/m	max. 10 V/m	max. 20 V/m	max. 20 V/m	max. 10 V/m
<b>Fast transients (burst)</b>						
EN 61000-4-4 IEEE C37.90.1	DC supply connection	±2 kV	±2 kV	±2 kV	±2 kV	±2 kV
EN 61000-4-4 IEEE C37.90.1	Data line	±4 kV	±4 kV	±2 kV	±2 kV	±2 kV
<b>Voltage surges - DC supply connection</b>						
EN 61000-4-5	line/ground	±2 kV	±2 kV	±2 kV	±2 kV	±2 kV
EN 61000-4-5	line/line	±1 kV	±1 kV	±1 kV	±1 kV	±1 kV
<b>Voltage surges - data line</b>						
EN 61000-4-5	line/ground	±1 kV	±1 kV	±2 kV	±2 kV	±2 kV
<b>Conducted disturbances</b>						
EN 61000-4-6	150 kHz ... 80 MHz	10 V	10 V	10 V	10 V	10 V
<b>Pulse magnetic field</b>						
EN 61000-4-9		—	—	300 A/m	300 A/m	—

Stability		Standard applications	Navy applications	Railway applications (trackside)	Railway applications (in vehicles)	Motor vehicle applications
IEC 60068-2-6, test Fc	Vibration	5 Hz ... 8.4 Hz with 0.14 in (3.5 mm) amplitude	2 Hz ... 13.2 Hz with 0.04 in (1 mm) amplitude	—	Operating 5 Hz ... 150 Hz, Broadband noise vertical: 1.0 m/s <sup>2</sup> (rms) horizontal: 0.7 m/s <sup>2</sup> (rms)	—
		8.4 Hz ... 150 Hz with 1 g	13.2 Hz ... 200 Hz with 0.7 g	—	Not operating: 5 Hz ... 150 Hz, Broadband noise vertical: 7.9 m/s <sup>2</sup> (rms) horizontal: 5.5 m/s <sup>2</sup> (rms)	—
IEC 60068-2-27, test Ea	Shock	15 g at 11 ms	—	—	vertical: 30 m/s <sup>2</sup> , 30 ms horizontal: 50 m/s <sup>2</sup> , 30 ms	—

## ■ Network range

**Note:** The line lengths specified for the transceivers apply for the respective fiber data (fiber attenuation and Bandwidth Length Product (BLP)/ Dispersion).

Product code M-FAST-SFP-...	Mode <sup>a</sup>	Wave length	Fiber	System attenuation	Example for F/O cable length <sup>b</sup>	Fiber attenuation	BLP/Dispersion
-MM/LC...	MM	1310 nm	50/125 µm	0 dB ... 7 dB	0 mi ... 2.49 mi (0 km ... 4 km)	1.0 dB/km	800 MHz×km
-MM/LC...	MM	1310 nm	62.5/125 µm	0 dB ... 10 dB	0 mi ... 2.49 mi (0 km ... 4 km)	1.0 dB/km	500 MHz×km
-SM/LC...	SM	1310 nm	9/125 µm	0 dB ... 12 dB	0 mi ... 13.98 mi (0 km ... 22.5 km)	0.4 dB/km	3.5 ps/(nm×km)
-SM+/LC...	SM	1310 nm	9/125 µm	10 dB ... 28 dB	15.53 mi ... 38.84 mi (25 km ... 62.5 km)	0.4 dB/km	3.5 ps/(nm×km)
-LH/LC...	SM	1550 nm	9/125 µm	10 dB ... 28 dB	29.20 mi ... 62.14 mi (47 km ... 100 km)	0.25 dB/km	19 ps/(nm×km)

Table 15: Fiber port 100BASE-FX (SFP fiber optic Fast Ethernet Transceiver)

- a. MM = Multimode, SM = Singlemode, LH = Singlemode Longhaul  
 b. Including 3 dB system reserve when compliance with the fiber data is observed.

Product code M-SFP-...	Mode <sup>a</sup>	Wave length	Fiber	System attenuation	Example for F/O cable length <sup>b</sup>	Fiber attenuation	BLP <sup>c</sup> /Dispersion
-SX/LC...	MM	850 nm	50/125 µm	0 dB ... 6.5 dB	0 mi ... 0.34 mi (0 km ... 0.55 km)	3.0 dB/km	400 MHz×km
-SX/LC...	MM	850 nm	62.5/125 µm	0 dB ... 6.5 dB	0 mi ... 0.171 mi (0 km ... 0.275 km)	3.2 dB/km	200 MHz×km

Table 16: F/O port 1000BASE-FX (SFP fiber optic Gigabit Ethernet Transceiver)

Product code M-SFP-...	Mode <sup>a</sup>	Wave length	Fiber	System attenuation	Example for F/O cable length <sup>b</sup>	Fiber attenuation	BLP <sup>c</sup> /Dispersion
-LX/LC...	SM	1310 nm	9/125 μm	0 dB ... 9.5 dB	0 mi ... 10.87 mi (0 km ... 17.5 km)	0.4 dB/km	3.5 ps/(nm×km)
-LH/LC...	LH	1550 nm	9/125 μm	5 dB ... 21 dB	14.29 mi ... 47.22 mi (23 km ... 76 km)	0.25 dB/km	19 ps/(nm×km)
-LH+/LC...	LH	1550 nm	9/125 μm	15 dB ... 29 dB	44.12 mi ... 64.62 mi (71 km ... 104 km)	0.25 dB/km	19 ps/(nm×km)

*Table 16: F/O port 1000BASE-FX (SFP fiber optic Gigabit Ethernet Transceiver)*

- a. MM = Multimode, SM = Singlemode, LH = Singlemode Longhaul
- b. Including 3 dB system reserve when compliance with the fiber data is observed.
- c. Using the bandwidth-length product is inappropriate for expansion calculations.

#### 10/100/1000 Mbit/s twisted pair port

Length of a twisted pair segment                      max. 328 ft (100 m) (for Cat5e cable)

*Table 17: Network range: 10/100/1000 Mbit/s twisted pair port*

## ■ Power consumption/power output, order numbers

The order numbers correspond to the product codes of the devices.  
See [“Device name and product code” on page 15.](#)

Device name	Maximum power consumption	Power output
OS20-000800...	22 W	75 Btu (IT)/h
OS20-001200...	26 W	87 Btu (IT)/h
OS20-002000...	27 W	94 Btu (IT)/h
OS20-002800...	29 W	100 Btu (IT)/h
OS24-xx1200... including 60 W PoE output power	103 W	140 Btu (IT)/h
OS24-xx2000... including 60 W PoE output power	106 W	149 Btu (IT)/h
OS24-xx2800... including 60 W PoE output power	108 W	157 Btu (IT)/h
OS30-0008xx...	26 W	87 Btu (IT)/h
OS30-0016xx..	27 W	94 Btu (IT)/h
OS30-0024xx..	29 W	100 Btu (IT)/h
OS34-xx08xx.. including 60 W PoE output power	103 W	140 Btu (IT)/h
OS34-xx16xx.. including 60 W PoE output power	106 W	149 Btu (IT)/h
OS34-xx24xx.. including 60 W PoE output power	108 W	157 Btu (IT)/h
OSx4-xxxxxx... including 120 W PoE output power	150 W	113 Btu (IT)/h

**Note:** The values for the maximum power output and the power consumption each apply to the fully expanded devices. See the type plate of the device for the exact specifications.

x = variable value

## ■ Scope of delivery

Number	Article
1 ×	General safety instructions

Number	Article
1 ×	Device
1 ×	M12 connector, 5-pin, (M12 socket, "A"-coded)
1 ×	Exclusively for device variants featuring supply voltage with characteristic value QQ or PP: M12 Power connector, 4-pin, "T"-coded
1 ×	Only for device variants featuring supply voltage with characteristic value FF: 7/8" connectors, 5-pin Design: ▶ HH - Hirschmann Standard ▶ HA - Hirschmann with angled connector
1 ×	Only for device variants featuring supply voltage with characteristic value N9: 7/8" connectors, 4-pin Design: ▶ HH - Hirschmann Standard ▶ HA - Hirschmann with angled connector
1 ×	Only for device variants featuring supply voltage with characteristic value M9: 7/8" connector, 3-pin
1 ×	Cable lug for fastening the protective conductor
1 ×	Exclusively for device variants with characteristic value hardware type 0 (Standard) in connection with supply voltage characteristic values M9, N9 or for device variants with the supply voltage characteristic value PP: Ferrite with key

## ■ Accessories

Name	Order number
Terminal cable	943 902-001
AutoConfiguration Adapter ACA21-M12 (EEC)	943 913-003
AutoConfiguration Adapter ACA22-M12 (EEC)	942 125-001
M12 connector - ELWIK A 5012 PG7 -,5-pin, (M12 socket, "A"-coded)	933 175-100
M12 connector - shielded -,5-pin, (M12 socket, "A"-coded)	942 219-001
M12 Power connector, 4-pin, "T"-coded	942 218 001
M12 connector, 4-pin, "D"-coded	934 445-001
7/8" connector, 3-pin	942 086-003
7/8" connectors, 4-pin	942 086-004
7/8" connectors, 5-pin	942 086-005
Protection screw for M12 socket, metal, IP65/67 (25 pieces)	942 057-001
Protection screw for M12 socket, plastic, IP65/67 (25 pieces)	942 057-002
Protection screw for M12 plug, metal, IP65/67 (10 pieces)	942 115-001
Connection cable with M12 connector, "D"-coded	934 497-00x
Transition M12 "D"-coded to RJ45	934 498-001
Network management software Industrial HiVision	943 156-xxx
PoE power supply unit (PC150/110V/54V)	942 242-001

## ■ Underlying technical standards

Name	
EN 55032	Electromagnetic compatibility of multimedia equipment – Emission Requirements
EN 61000-6-2	Electromagnetic compatibility (EMC) – Part 6-2: Generic standards – Immunity for industrial environments
EN 61000-6-4	Electromagnetic compatibility (EMC) – Part 6-4: Generic standards – Emitted interference in industrial environments
EN 60950-1	Information technology equipment – Safety – Part 1: General requirements
CSA 22.2 No. 60950-1	Information Technology Equipment – Safety – Part 1: General Requirements
EN 61131-2	Programmable controllers – Part 2: Equipment requirements and tests
FCC 47 CFR Part 15	Code of Federal Regulations
DNVGL-CG-0339	Environmental test specification for electrical, electronic and programmable equipment and systems.
ECE No. 10	E type approval for use in vehicles
EN 45545-2	Railway applications - Fire protection on railway vehicles - Part 2: Requirements for fire behavior of materials and components.
EN 50121-4	Railway applications – EMC – Emission and immunity of the signaling and telecommunications apparatus (Rail Trackside)
EN 50155	Railway applications – Electronic equipment used on rolling stock
EN 55011	Industrial, scientific and medical equipment – Radio disturbance – Limits and methods of measurement

*Table 18: List of the technical standards*

The device has an approval based on a specific standard exclusively if the approval indicator appears on the device casing.

The device generally fulfills the technical standards named in their current versions.

If your device has a shipping approval according to DNV GL, you find the approval mark printed on the device label. You will find out whether your device has other shipping approvals on the Hirschmann website at [www.hirschmann.com](http://www.hirschmann.com) in the product information.



# A Further support

## Technical questions

For technical questions, please contact any Hirschmann dealer in your area or Hirschmann directly.

You find the addresses of our partners on the Internet at <http://www.hirschmann.com>.

A list of local telephone numbers and email addresses for technical support directly from Hirschmann is available at <https://hirschmann-support.belden.com>.

This site also includes a free of charge knowledge base and a software download section.

## Hirschmann Competence Center

The Hirschmann Competence Center is ahead of its competitors on three counts with its complete range of innovative services:

- ▶ Consulting incorporates comprehensive technical advice, from system evaluation through network planning to project planning.
- ▶ Training offers you an introduction to the basics, product briefing and user training with certification.  
You find the training courses on technology and products currently available at <http://www.hicomcenter.com>.
- ▶ Support ranges from the first installation through the standby service to maintenance concepts.

With the Hirschmann Competence Center, you decided against making any compromises. Our client-customized package leaves you free to choose the service components you want to use.

Internet:

<http://www.hicomcenter.com>



**HIRSCHMANN**

---

A **BELDEN** BRAND