



**HIRSCHMANN**

A **BELDEN** BRAND

# User Manual

## Installation

### Industrial Ethernet Ruggedized Switch MACH1040 family Full Gigabit

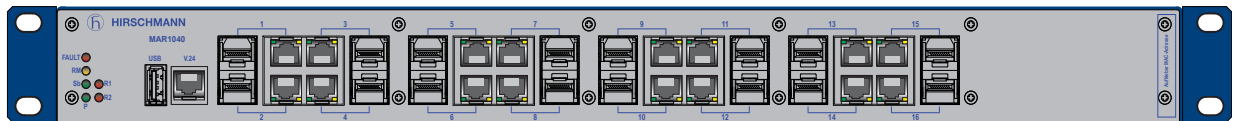

MAR1040

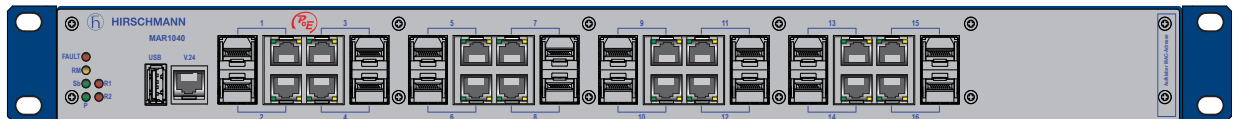

MAR1042

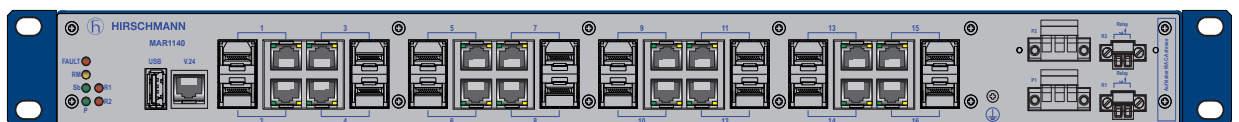

MAR1140

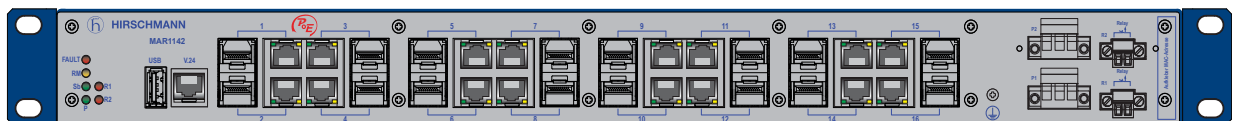

MAR1142



MAR1140, MAR1142

The naming of copyrighted trademarks in this manual, even when not specially indicated, should not be taken to mean that these names may be considered as free in the sense of the trademark and tradename protection law and hence that they may be freely used by anyone.

© 2021 Hirschmann Automation and Control GmbH

Manuals and software are protected by copyright. All rights reserved. The copying, reproduction, translation, conversion into any electronic medium or machine scannable form is not permitted, either in whole or in part. An exception is the preparation of a backup copy of the software for your own use.

The performance features described here are binding only if they have been expressly agreed when the contract was made. This document was produced by Hirschmann Automation and Control GmbH according to the best of the company's knowledge. Hirschmann reserves the right to change the contents of this document without prior notice. Hirschmann can give no guarantee in respect of the correctness or accuracy of the information in this document.

Hirschmann can accept no responsibility for damages, resulting from the use of the network components or the associated operating software. In addition, we refer to the conditions of use specified in the license contract.

You can get the latest version of this manual on the Internet at the Hirschmann product site ([www.hirschmann.com](http://www.hirschmann.com)).

Hirschmann Automation and Control GmbH  
Stuttgarter Str. 45-51  
72654 Neckartenzlingen  
Germany

# Contents

<b>Important information</b>	<b>5</b>
<b>Safety instructions</b>	<b>7</b>
<b>About this Manual</b>	<b>15</b>
<b>Key</b>	<b>16</b>
<b>1 Description</b>	<b>17</b>
1.1 General device description	17
1.2 Combination options	18
1.3 Description of the device variants	19
1.3.1 Support of PoE	23
1.4 Gigabit combo port	24
1.4.1 10/100/1000 Mbit/s twisted pair port	24
1.4.2 100/1000 Mbit/s F/O port	25
1.4.3 Pin assignments	25
1.5 Display elements	25
1.5.1 Device state	26
1.5.2 LED display elements port status	28
1.6 Management interfaces	30
1.6.1 V.24 interface (external management)	30
1.6.2 USB interface	30
1.7 Signal contact	31
<b>2 Installation</b>	<b>32</b>
2.1 Checking the package contents	32
2.2 Installing an SFP transceiver (optional)	32
2.3 Wiring of the terminal blocks for supply voltage and signal contact	33
2.3.1 Connecting the supply voltage	34
2.3.2 Wiring the signal contact	35
2.4 Installing and grounding the device	36
2.4.1 Mounting in a switch cabinet	36
2.4.2 Vertical mounting on the wall	38

2.4.3	Grounding the device	38
2.5	Operating the device	39
2.6	Connecting data cables	39
2.6.1	Twisted Pair ports	39
2.6.2	Optical fiber ports	39
<b>3</b>	<b>Making basic settings</b>	<b>40</b>
3.1	First login (Password change)	41
<b>4</b>	<b>Monitoring the ambient air temperature</b>	<b>42</b>
<b>5</b>	<b>Maintenance and service</b>	<b>43</b>
<b>6</b>	<b>Disassembly</b>	<b>44</b>
6.1	Removing the device	44
6.2	Removing an SFP transceiver (optional)	44
<b>7</b>	<b>Technical data</b>	<b>45</b>
7.1	General technical data	45
7.2	Dimension drawings	47
7.3	EMC and immunity	49
7.4	Network range	51
7.4.1	10/100/1000 Mbit/s twisted pair port	51
7.4.2	Fast Ethernet SFP transceiver	51
7.4.3	Bidirectional Fast Ethernet SFP transceiver	52
7.4.4	Gigabit Ethernet SFP transceiver	53
7.4.5	Bidirectional Gigabit Ethernet SFP transceiver	54
7.5	Power consumption/power output	56
7.6	Scope of delivery	56
7.7	Order numbers/product description	57
7.8	Accessories	57
7.9	Underlying technical standards	60
<b>A</b>	<b>Further support</b>	<b>61</b>

# Important information

**Note:** Read these instructions carefully, and familiarize yourself with the device before trying to install, operate, or maintain it. The following notes may appear throughout this documentation or on the device. These notes warn of potential hazards or call attention to information that clarifies or simplifies a procedure.

## ■ Symbol explanation



This is a general warning symbol. This symbol alerts you to potential personal injury hazards. Observe all safety notes that follow this symbol to avoid possible injury or death.



If this symbol is displayed in addition to a safety instruction of the type “Danger” or “Warning”, it means that there is a danger of electric shock and failure to observe the instructions will inevitably result in injury.



This symbol indicates the danger of hot surfaces on the device. In connection with safety instructions, non-observance of the instructions will inevitably result in injuries.



## **DANGER**

**DANGER** draws attention to an immediately dangerous situation, which will **inevitably** result in a serious or fatal accident if not observed.



## **WARNING**

**WARNING** indicates a potentially hazardous situation which, if not avoided, **could** result in death or serious injury.



## **CAUTION**

**CAUTION** indicates a possible danger which, if not avoided, **may** result in minor injuries.

# NOTICE

**NOTE** provides information about procedures that do not involve the risk of injury.

# Safety instructions

## **WARNING**

### **UNCONTROLLED MACHINE ACTIONS**

To avoid uncontrolled machine actions caused by data loss, configure all the data transmission devices individually.

Before you start any machine which is controlled via data transmission, be sure to complete the configuration of all data transmission devices.

**Failure to follow these instructions can result in death, serious injury, or equipment damage.**

### ■ **General safety instructions**

You operate this device with electricity. Improper usage of the device entails the risk of physical injury or significant property damage. The proper and safe operation of this device depends on proper handling during transportation, proper storage and installation, and careful operation and maintenance procedures.

- Before connecting any cable, read this document, and the safety instructions and warnings.
- Operate the device with undamaged components exclusively.
- The device is free of any service components. In case of a damaged or malfunctioning device, turn off the supply voltage and return the device to Hirschmann for inspection.

### ■ **Certified usage**

- Use the product only for the application cases described in the Hirschmann product information, including this manual.
- Operate the product only according to the technical specifications. [See “Technical data” on page 45.](#)
- Connect to the product only components suitable for the requirements of the specific application case.

### ■ **Installation site requirements**

- Install this device only in a switch cabinet or in an operating site with restricted access, to which maintenance staff have exclusive access.
- Mount the device horizontally in a cabinet or vertically on a flat surface. Operating the device as a table unit is inadmissible. [See “General technical data” on page 45.](#)
- Install the device in a fire protected shell if you are mounting it vertically.

- If you are operating the device in a 19" switch cabinet: install sliding/mounting rails for supporting the weight of the device.
- When you are selecting the installation location, make sure you observe the climatic threshold values specified in the technical data.
- Use the device in an environment with a maximum pollution degree that complies with the specifications in the technical data.

## ■ **Strain relief**

**Note:** If the strain relief is insufficient, there is a risk of torsion, contact problems and creeping interruptions.

- Relieve the connection points of cables and lines from mechanical stress.
- Design strain relieves in such a way that they prevent any mechanical damage to cables, wires or conductors caused by external influences or their own weight.
- To prevent damage to device connections, connectors and cables, follow the instructions for proper installation in accordance with DIN VDE 0100-520:2013-06, sections 522.6, 522.7 and 522.13.

## ■ **Device casing**

Only technicians authorized by the manufacturer are permitted to open the casing.

- Make sure there is at least 3.94 in (10 cm) of space in front of the ventilation slits of the casing.  
[See "General technical data" on page 45.](#)
- Never insert pointed objects (narrow screwdrivers, wires, etc.) into the device or into the connection terminals for electric conductors. Do not touch the connection terminals.
- Do not touch the housing during operation or shortly after switching off the device. Hot surfaces can cause injury.
- Operating the device in the maximum surrounding air temperature and stacking devices: When installing the device, make sure there is at least 1 free rack space (approx. 5 cm) above the device, because heat is discharged via the housing of the device.

## ■ **Qualification requirements for personnel**

- Only allow qualified personnel to work on the device.

Qualified personnel have the following characteristics:

- ▶ Qualified personnel are properly trained. Training as well as practical knowledge and experience make up their qualifications. This is the prerequisite for grounding and labeling circuits, devices, and systems in accordance with current standards in safety technology.
- ▶ Qualified personnel are aware of the dangers that exist in their work.



- ▶ Qualified personnel are familiar with appropriate measures against these hazards in order to reduce the risk for themselves and others.
- ▶ Qualified personnel receive training on a regular basis.

### ■ **National and international safety regulations**

- Verify that the electrical installation meets local or nationally applicable safety regulations.

### ■ **Grounding the device**

The device is grounded via the separate grounding screw on the back of the device.

- Use a wire diameter for the ground conductor that is no smaller than the diameter of the supply voltage connection, however of at least 1.0 mm<sup>2</sup> (AWG16).
- Ground the device before connecting any other cables.
- Disconnect the grounding only after disconnecting all other cables.

### ■ **Shielded ground**

The shielded ground wire of the twisted pairs cables is connected to the front panel as a conductor.

Beware of possible short circuits when connecting a cable section with conductive shield braiding.

### ■ **Supply voltage**

The supply voltage is electrically isolated from the casing.

Exclusively connect a supply voltage that corresponds to the type plate of your device.

- Every** time you connect the electrical conductors, make sure that the following requirements are met:
  - ▶ The power supply conforms to overvoltage category I or II.
  - ▶ The power supply has an easily accessible disconnecting device (for example a switch or a plug). This disconnecting device is clearly identified. So in the case of an emergency, it is clear which disconnecting device belongs to which power supply cable.
  - ▶ The electrical wires are voltage-free.
  - ▶ The ground screw on the back of the device is connected to the protective conductor.
  - ▶ There is a fuse in the outer conductor (AC) or the positive conductor (DC) of the voltage supply.  
Regarding the properties of this fuse: [See “General technical data” on page 45.](#)
  - ▶ Supply with DC voltage: the fuse is suitable for a DC voltage.
  - ▶ If the neutral conductor (AC) or the negative conductor (DC) is not grounded: there is a fuse in each of the two wires.
  - ▶ The wire diameter of the power supply cable is at least 1 mm<sup>2</sup> (North America: AWG16) on the supply voltage input.

- ▶ The cross-section of the protective conductor is the same size as or bigger than the cross-section of the power supply cables.
  - ▶ The cables used are permitted for the temperature range of the application case.
  - ▶ Relevant for North America:  
The power supply lines are made up of copper wire.
- Start connecting the electrical wires only if **all** the above safety requirements are fulfilled.
  - Verify that the electrical installation meets locally or nationally applicable safety regulations.
  - Use undamaged parts.
  - Internal fuses are triggered only in the case of a detected error in the device. In case of damage or malfunction of the device, turn off the supply voltage and return the device to the plant for inspection.
  - Only switch on the device when the housing is closed.
  - First connect the ground screw on the back of the device with the protective conductor before you set up the other connections. When removing the connections, you remove the protective conductor last.
  - For supply voltage connections with protective conductor connection: First connect the protective conductor before connecting the wires for the supply voltage.  
If your device comprises a 2nd supply voltage connection of this type: First connect the protective conductor before connecting the wires for the supply voltages.

## ■ Use in Hazardous Locations

### Relevant for use in Hazardous Locations (Class 1, Division 2)::

This equipment is suitable for use in Class 1, Division 2, Groups A, B, C and D or Non-Hazardous (unclassified) locations only.

When used in Class 1 Division 2 Hazardous Locations, the following applies:



CLASS I; DIV. 2

GROUPS A; B; C; D

TEMPERATURE CODE T4

AMBIENT -30 °C ... +70 °C

List of Standards: ISA 12.12.01:2007, CSA C22.2 No. 213-M1987

This equipment must be installed in a tool-locked enclosure when the USB port will be used.



**Warning:** Do not remove or replace while circuit is live unless the area is known to be free of ignitable concentrations or flammable substances.

**Avertissement** - Risque d'explosion - Ne pas débrancher tant que le circuit est sous tension à moins que l'emplacement soit connu pour ne contenir aucune concentration de gaz inflammable.

**Avertissement** - Risque d'explosion - La substitution de tout composant peut rendre ce matériel incompatible pour une utilisation en classe I, division 2.

**For use in Hazardous Locations according ISA12.12.01-2007 Class I Div. 2 Groups A, B, C, D  
Control Drawing MACH1040-Family**

Hazardous Location

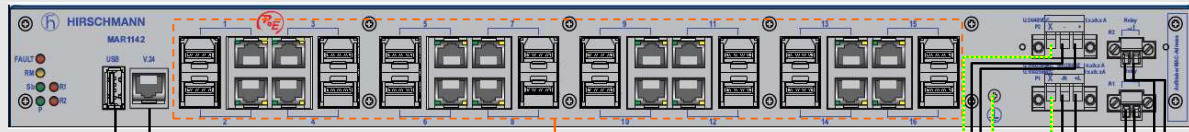

**ACA21-USB**  
Auto  
Configuration  
Adapter  
For maintenance  
only – See  
Installation  
Instructions

**V.24 Interface**  
(External  
management)

**Data  
communication**  
Ethernet Ports

**Power Supply 1**  
L: 24VDC to 48VDC  
M: 100VAC to  
240VAC 50/60Hz  
**Power Supply 2**  
9: Not present  
L: 24VDC to 48VDC  
M: 100VAC to  
240VAC 50/60Hz

**Signal Contacts**  
(On: O.K.  
Open: fault)  
Associated  
Apparatus:  
Equipment with  
nonincendive  
field wiring  
parameters

Ordinary Location - Non-Hazardous Area

The Use in Hazardous Locations is only allowed for MACH1040-Family model No's which are individually labelled "FOR USE IN CLASS I, DIVISION 2 HAZARDOUS LOCATIONS"

**Notes:**

The nonincendive field wiring circuit concept allows interconnection of nonincendive field wiring apparatus and associated nonincendive field wiring apparatus using any of the wiring methods permitted for unclassified locations when certain parametric conditions are met.

Capacity:  $C_a \geq C_i + C_{Cable}$

Inductivity:  $L_a \geq L_i + L_{Cable}$

The maximum cable length has to be determined as follows:

(a) max. Cable Length  $< (L_a - L_i) / Cable_L$  and (b) max. Cable Length  $< (C_a - C_i) / Cable_c$

The lower value of (a) and (b) is to apply.

Cable  $L$  : inductance per unit length of used cable.

Cable  $c$  : capacitance per unit length of used cable.

Other C-parameters and L-parameters are according to ANSI / ISA 12.12.01 2007 section 7.

Where cable capacitance and inductance values are unavailable, use the following default values: 60pF/foot (200pF/m), 0.2uH/foot (0,7uH/m)

Nonincendive field wiring circuits must be wired in accordance with the National Electrical Code (NEC), NFPA 70 , article 501.

The Relay Terminals are dependent upon the following Entity Parameters:

Vmax	Imax	Ci	Li
30V	90mA	50pF	2μH



**The MACH1040-Family is an open type which must be installed within an enclosure appropriate for environmental protection.**

**WARNING - Explosion Hazard – Do not disconnect Equipment while the circuit is live or unless the area is known to be free of ignitable concentrations.**

**WARNING – Explosion Hazard – Substitution of any component may impair suitability for Class I, Division 2.**

**Do not open when energized.**

**CONTROL DRAWING for Full Gigabit Ethernet Switch**  
**MACH1040 Family**  
according to ANSI / ISA-12.12.01 – 2007



Rev.: 2      Date: 2011-03-18      Document No.: 000154226DNR      Page 1 of 1

## ■ **CE marking**

The labeled devices comply with the regulations contained in the following European directive(s):

2011/65/EU and 2015/863/EU (RoHS)

Directive of the European Parliament and of the Council on the restriction of the use of certain hazardous substances in electrical and electronic equipment.

2014/30/EU (EMC)

Directive of the European Parliament and of the Council on the harmonisation of the laws of the Member States relating to electromagnetic compatibility.

2014/35/EU

Directive of the European Parliament and of the Council on the harmonisation of the laws of the Member States relating to the making available on the market of electrical equipment designed for use within certain voltage limits.

In accordance with the above-named EU directive(s), the EU conformity declaration will be at the disposal of the relevant authorities at the following address:

Hirschmann Automation and Control GmbH  
Stuttgarter Str. 45-51  
72654 Neckartenzlingen

You find the EU conformity declaration as PDF file for downloading on the Internet at: <https://www.doc.hirschmann.com/certificates.html>

The product can be used in the industrial sector.

- ▶ Interference immunity: EN 61000-6-2
- ▶ Emitted interference: EN 55032
- ▶ Safety: EN 62368-1

The assembly guidelines provided in these instructions must be strictly adhered to in order to observe the EMC threshold values.

**Warning!** This is a class A device. This device can cause interference in living areas, and in this case the operator may be required to take appropriate measures.

## ■ **LED or laser components**

LED or LASER components according to IEC 60825-1 (2014):

CLASS 1 LASER PRODUCT

CLASS 1 LED PRODUCT

## ■ **FCC note**

### **Supplier's Declaration of Conformity 47 CFR § 2.1077 Compliance Information**

MACH1040

#### **U.S. Contact Information**

Belden – St. Louis  
1 N. Brentwood Blvd. 15th Floor  
St. Louis, Missouri 63105, United States  
Phone: 314.854.8000

This device complies with part 15 of the FCC Rules. Operation is subject to the following two conditions: (1) This device may not cause harmful interference, and (2) this device must accept any interference received, including interference that may cause undesired operation.

**Note:** This equipment has been tested and found to comply with the limits for a Class A digital device, pursuant to part 15 of the FCC Rules. These limits are designed to provide reasonable protection against harmful interference when the equipment is operated in a commercial environment. This equipment generates, uses, and can radiate radio frequency energy and, if not installed and used in accordance with the instruction manual, may cause harmful interference to radio communications. Operation of this equipment in a residential area is likely to cause harmful interference in which case the user will be required to correct the interference at his own expense.

## ■ **Recycling note**

After usage, this device must be disposed of properly as electronic waste, in accordance with the current disposal regulations of your county, state, and country.

# About this Manual

The “Installation” user manual contains a device description, safety instructions, a description of the display, and the other information that you need to install the device.

The following manuals are available as PDF files for download on the Internet at <https://www.doc.hirschmann.com/> :

- ▶ User Manual Installation
- ▶ User Manual Basic Configuration
- ▶ User Manual Redundancy Configuration
- ▶ Reference Manual Graphical User Interface
- ▶ Reference Manual Command Line Interface
- ▶ Router Configuration user manual

The Network Management Software Industrial HiVision provides you with options for smooth configuration and monitoring. You find further information on the Internet at the Hirschmann product pages:

<http://www.hirschmann.com/en/QR/INET-Industrial-HiVision>

# Key

The symbols used in this manual have the following meanings:

▶	Listing
□	Work step
■	Subheading



# 1 Description

## 1.1 General device description

You can choose from a wide range of variants. You have the option to set up your device individually based on different criteria:

- ▶ Media type
- ▶ Temperature range
- ▶ Supply voltage range
- ▶ Software variant

The device is designed for the special requirements of industrial automation. The device meets the relevant industry standards, provides very high operational reliability, even under extreme conditions, and also long-term reliability and flexibility.

The device allows you to set up switched Industrial Ethernet networks according to standard IEEE 802.3.

The device works without a fan.

The device is available with or without PoE functionality.

For devices without PoE, the voltage supply can be redundant if required.

The following installation options are available:

- ▶ 19" switch cabinet
- ▶ Flat surface mounting

You have the option of choosing various media to connect to the end devices and other network components:

- ▶ Twisted pair cable
- ▶ Multimode F/O
- ▶ Singlemode F/O

The ring redundancy concept allows the network to be reconfigured quickly after a failure.

Product configuration data can be provided by:

- ▶ diagnosis displays
- ▶ Display of the operating parameters

There are convenient options for managing the device. Manage your devices via:

- ▶ Web browser
- ▶ Telnet
- ▶ HiView (software for putting the device into operation)
- ▶ Network management software (for example Industrial HiVision)
- ▶ V.24 interface (locally on the device)

The device provides you with a large range of functions, which the manuals for the operating software inform you about. You can download these manuals as PDF files from the Internet on the Hirschmann product pages (<http://www.doc.hirschmann.com>).

The Hirschmann network components help you ensure continuous communication across all levels of the company.

## 1.2 Combination options

The product designation of your device is made from combining the desired product characteristics in accordance with the following table. The corresponding short designation is in column 3.

You have numerous options of combining the device characteristics. You can determine the possible combinations using the configurator which is available in the Belden Online Catalog <https://catalog.belden.com> on the web page of the device.

Position	Characteristic	Designation	Property
1 ... 7	Product	MAR1040	MACH Ruggedized Gigabit Ethernet Switch
		MAR1042	MACH Ruggedized Gigabit Ethernet Switch with PoE
		MAR1140	MACH Ruggedized Gigabit Ethernet Switch, ports on the rear
		MAR1142	MACH Ruggedized Gigabit Ethernet Switch, ports on the rear and with PoE
8	-	(hyphen)	-
9 ... 10	10/100/1000 Mbit/s port 1 ... 4	4C	4 × Combo port (SFP slot: 100/1000 Mbit/s, alternatively twisted pair RJ45 socket: 10/100/1000 Mbit/s)
11 ... 12	10/100/1000 Mbit/s port 5 ... 8	4C	See 9 ... 10
13 ... 14	10/100/1000 Mbit/s port 9 ... 10	4C	See 9 ... 10
15 ... 16	10/100/1000 Mbit/s port 13 ... 16	4C	See 9 ... 10
17 ... 18	Port 17 ... 20	99	Not present
19 ... 20	Port 21 ... 24	99	Not present
21	Temperature range	S	Standard: 0 °C ... +60 °C (+32 °F ... +140 °F)
		T	Extended: -40 °C ... +70 °C (-40 °F ... +158 °F)
		E	Extended: -40 °C ... +70 °C (-40 °F ... +158 °F), Conformal Coating
22	Supply voltage range, power supply unit 1	L	See "General technical data" on page 45.
		M	

Table 1: Combination options of the MACH1040 device variants

Position	Characteristic	Designation	Property
23	Supply voltage range, power supply unit 2 or PoE power supply unit	9	Not present
		L	See <a href="#">“General technical data” on page 45.</a>
		M	
24	Approvals	H	CE, UL 508, ISA 12.12.01 Class I Division 2, GL, IEC 61850, IEEE 1613 Substation, EN 50121-4 Railway (trackside), NEMA TS2
		T	CE, UL 508, ISA 12.12.01 - Class I Div. 2, EN 50121-4 Railway (trackside), NEMA TS2, EN 50155 Railway (train)
25	Software variant	P	Layer 2 Professional
		R	Layer 3 Professional

*Table 1: Combination options of the MACH1040 device variants*

### 1.3 Description of the device variants

- ▶ The MACH1040 devices are Ruggedized Switches with 16 × 1-Gigabit Ethernet ports (10/100/1000 Mbit/s, connectible alternatively with optical SFP transceivers or twisted pair cables). These ports are suitable for the connection of terminal devices or network segments according to the standards IEEE 802.3 100/1000BASE-FX (SFP slot) or IEEE 802.3 1000BASE-T/100BASE-TX/10BASE-T (RJ45 socket). A plugged SFP transceiver switches off the twisted pair port.
- ▶ On the MAR1140... and MAR1142... devices, the ports are on the rear side of the device. These devices have 1 additional Fast Ethernet port on the front side of the device, which can be used for diagnostic purposes.
- ▶ The MAR1042... and MAR1142... devices support PoE (Power over Ethernet) according to IEEE 802.3af. The Gigabit Ethernet ports 1 ... 4 are PoE ports.

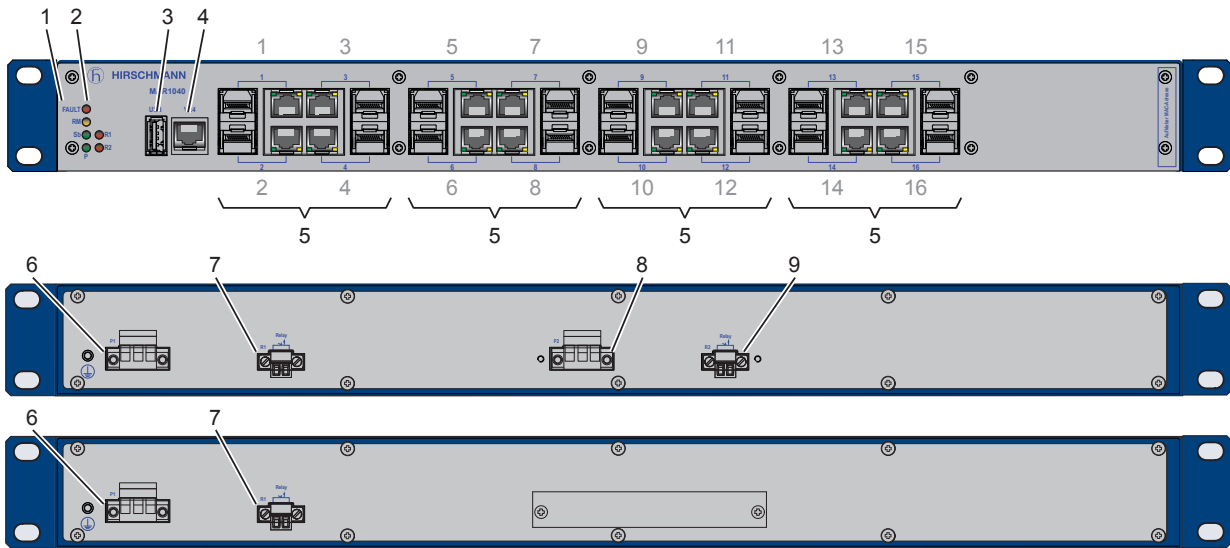

Front side of the device:

- 1 MAR1040 device
- 2 LED display elements
- 3 USB interface
- 4 V.24 interface (external management)
- 5 Gigabit Ethernet combo ports: 100/1000 Mbit/s SFP slots or alternatively 10/100/1000 Mbit/s twisted pair sockets (RJ45)

Rear side of the device:

- 6 P1: Supply voltage connection
- 7 Relay 1: Signal contact

Rear side of device variants with 2 power supply units:

- 8 P2: Redundant supply voltage connection
- 9 Relay 2: Signal contact

**Table 2: Description of the device variants: MAR1040-... with 16 × 1GE ports**

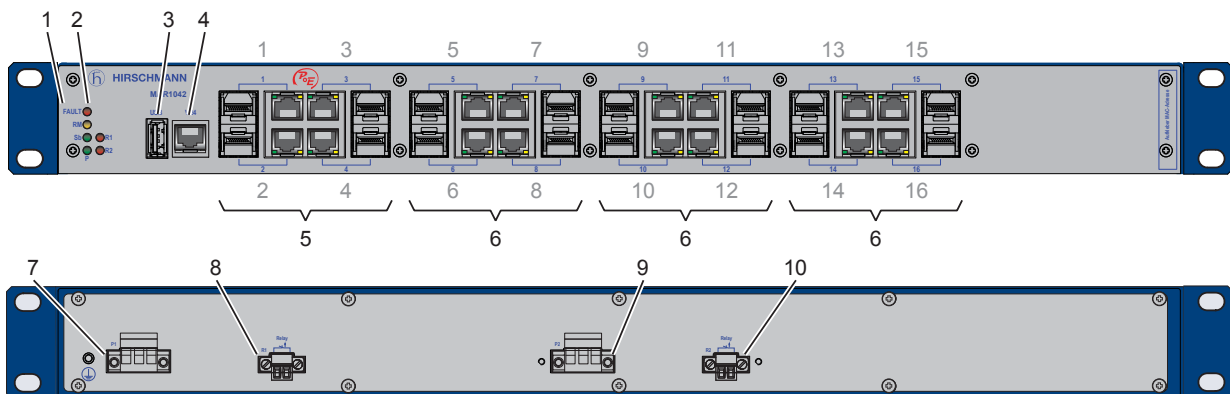

Front side of the device:

- 1 MAR1042 device
- 2 LED display elements
- 3 USB interface
- 4 V.24 interface (external management)

**Table 3: Description of the device variants: MAR1042-... with 16 × 1GE ports and PoE**

5 Gigabit Ethernet combo ports with Power over Ethernet (PoE): 100/1000 Mbit/s SFP slots or alternatively 10/100/1000 Mbit/s twisted pair sockets (RJ45)

6 Gigabit Ethernet combo ports: 100/1000 Mbit/s SFP slots or alternatively 10/100/1000 Mbit/s twisted pair sockets (RJ45)

Rear side of the device:

7 P1: Supply voltage connection

8 Relay 1: Signal contact

9 P2: PoE supply voltage connection

10 Relay 2: Signal contact

Table 3: Description of the device variants: MAR1042-... with 16 × 1GE ports and PoE

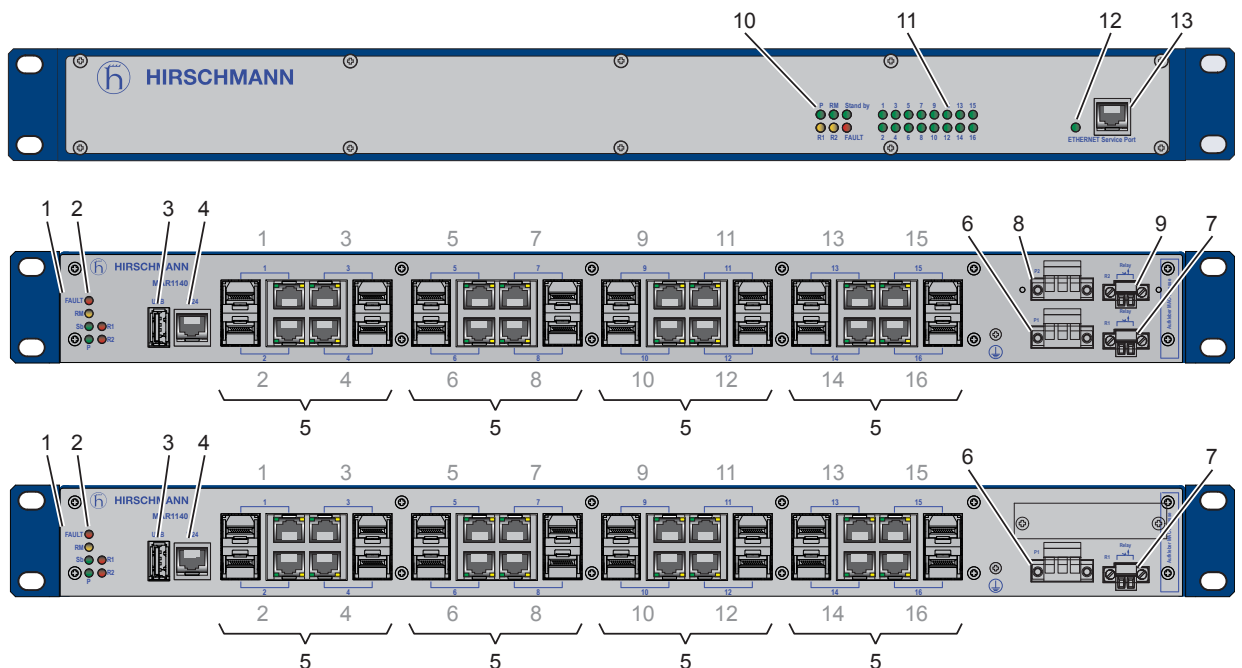

Rear side of the device:

1 MAR1140 device

2 LED display elements

3 USB interface

4 V.24 interface (external management)

5 Gigabit Ethernet combo ports: 100/1000 Mbit/s SFP slots or alternatively 10/100/1000 Mbit/s twisted pair sockets (RJ45)

6 P1: Supply voltage connection

7 Relay 1: Signal contact

Rear side of device variants with 2 power supply units:

8 P2: Redundant supply voltage connection

9 Relay 2: Signal contact

Front side of the device:

10 LED display elements device status

11 LED display elements port status

Table 4: Description of the device variants: MAR1140-... with 16 × 1GE ports, ports on the rear side of the device

12 LED display element service port

13 Service port

Table 4: Description of the device variants: MAR1140-... with 16 × 1GE ports, ports on the rear side of the device

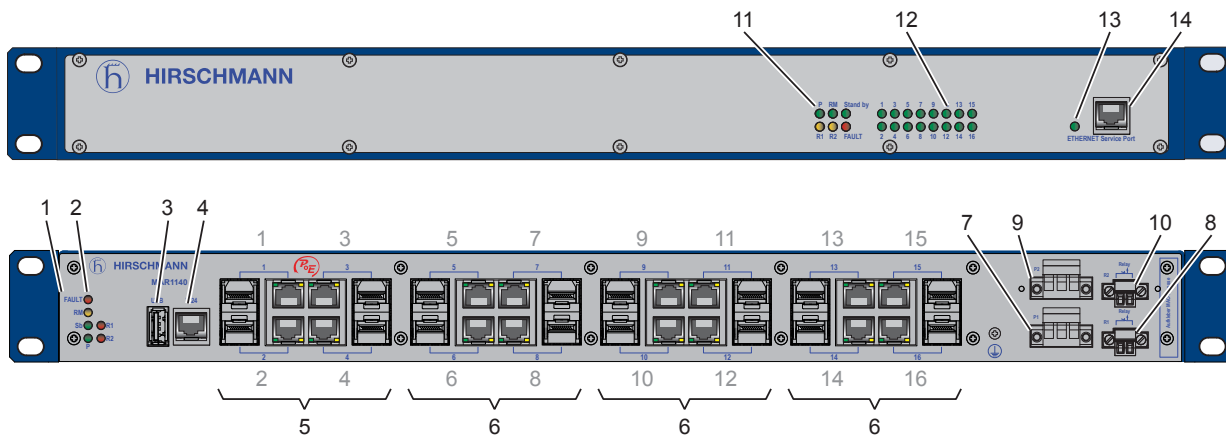

Rear side of the device:

1 MAR1142 device

2 LED display elements

3 USB interface

4 V.24 interface (external management)

5 Gigabit Ethernet combo ports with Power over Ethernet (PoE): 100/1000 Mbit/s SFP slots or alternatively 10/100/1000 Mbit/s twisted pair sockets (RJ45)

6 Gigabit Ethernet combo ports: 100/1000 Mbit/s SFP slots or alternatively 10/100/1000 Mbit/s twisted pair sockets (RJ45)

7 P1: Supply voltage connection

8 Relay 1: Signal contact

9 P2: PoE supply voltage connection

10 Relay 2: Signal contact

Front side of the device:

11 LED display elements device status

12 LED display elements port status

13 LED display element service port

14 Service port

Table 5: Description of the device variants: MAR1142-... with 16 × 1GE ports and PoE, ports on the rear side of the device

Device variants with ports on the rear have the following properties:

- ▶ On the device, there are 16 LED display elements for the port status of the 1-Gigabit Ethernet ports as well as 6 LED display elements to display the device status. The LED display elements are located on the front side of the device.
- ▶ The supply voltage connection and the ports are located on the rear side of the device. The device has 16 × 1-Gigabit Ethernet ports as well as 1 additional Fast Ethernet port on the front side of the device, which can be used for diagnostic purposes.

### **1.3.1 Support of PoE**

The MAR1042... and MAR1142... devices support PoE (Power over Ethernet) according to IEEE 802.3af.

They allow the connection and remote supply of, for example, IP telephones (Voice over IP), webcams, sensors, printer servers and WLAN access points via 10BASE-T/100BASE-TX/1000BASE-T. With PoE, these terminal devices are powered by the twisted-pair cable.

The MAR1042 and MAR1142 device variants provide 4 × 10BASE-T/100BASE-TX/1000BASE-T ports (RJ45 sockets) for connecting network segments or PoE terminal devices (PD, Powered Device) for all IEEE802.3af classes up to a maximum power output of 15.4 W per port.

The 4 PoE-capable ports are the 4 first ports of the device (Port 1 ... 4, see [table 3 on page 20](#) and [table 5 on page 22](#)). The PoE ports are marked with the red PoE logo on the device.

The PoE power is supplied via the wire pairs transmitting the signal (phantom voltage).

The individual ports are not electrically insulated from each other.

The following conditions are met in accordance with IEEE 802.3af:

- ▶ Endpoint PSE
- ▶ Alternative A

## 1.4 Gigabit combo port

The MACH1040 device provides 16 combo ports for transmission speeds of up to 1000 Mbit/s.

You have the option of alternatively connecting a twisted pair cable via a RJ45 socket or an optical fiber via a SFP transceiver to a combo port.

(see [table 2 on page 20](#) to [table 5 on page 22](#))

By inserting a SFP transceiver, you deactivate automatically the corresponding twisted pair interface.

Use only Hirschmann SFP transceivers which are suitable for usage with the device.

See [“Accessories” on page 57](#).

You find information on the pin assignments for making patch cables here: [“Pin assignments” on page 25](#)

### 1.4.1 10/100/1000 Mbit/s twisted pair port

This port is an RJ45 socket.

The 10/100/1000 Mbit/s twisted pair port allows you to connect network components according to the IEEE 802.3 10BASE-T/100BASE-TX/1000BASE-T standard.

The MAR1042 and MAR1142 devices also allow: IEEE 802.3af (Power over Ethernet on data lines).

This port supports:

- ▶ Autonegotiation
- ▶ Autopolarity
- ▶ Autocrossing (if autonegotiation is activated)
- ▶ 1000 Mbit/s full duplex
- ▶ 100 Mbit/s half-duplex mode, 100 Mbit/s full duplex mode
- ▶ 10 Mbit/s half-duplex mode, 10 Mbit/s full duplex mode
- ▶ Also for MAR1042 and MAR1142:
  - Power over Ethernet (PoE) at the first 4 ports of the device
  - The PoE power is supplied via the wire pairs transmitting the signal (phantom voltage).

Delivery state: Autonegotiation activated

The port casing is electrically connected to the front panel.

The pin assignment corresponds to MDI-X.



## 1.4.2 100/1000 Mbit/s F/O port

This port is an SFP slot.

The 100/1000 Mbit/s F/O port allows you to connect network components according to the IEEE 802.3 100BASE-FX/1000BASE-SX/1000BASE-LX standard.

This port supports:

- ▶ 1000 Mbit/s full duplex
- ▶ 100 Mbit/s half-duplex mode, 100 Mbit/s full duplex mode

Delivery state:

- ▶ 100 Mbit/s full duplex when using a Fast Ethernet SFP transceiver
- ▶ 1000 Mbit/s full duplex when using a Gigabit Ethernet SFP transceiver

## 1.4.3 Pin assignments

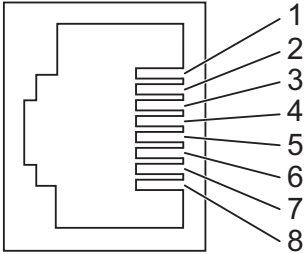
RJ45	Pin	10/100 Mbit/s	1000 Mbit/s	PoE
	<b>MDI mode</b>			
	1	TX+	BI_DA+	Positive $V_{PSE}^a$
	2	TX-	BI_DA-	Positive $V_{PSE}^a$
	3	RX+	BI_DB+	Negative $V_{PSE}^a$
	4	—	BI_DC+	Positive $V_{PSE}^b$
	5	—	BI_DC-	Positive $V_{PSE}^b$
	6	RX-	BI_DB-	Negative $V_{PSE}^a$
	7	—	BI_DD+	Negative $V_{PSE}^b$
	8	—	BI_DD-	Negative $V_{PSE}^b$
	<b>MDI-X mode</b>			
	1	RX+	BI_DB+	Negative $V_{PSE}^a$
	2	RX-	BI_DB-	Negative $V_{PSE}^a$
	3	TX+	BI_DA+	Positive $V_{PSE}^a$
	4	—	BI_DD+	Positive $V_{PSE}^b$
	5	—	BI_DD-	Positive $V_{PSE}^b$
	6	TX-	BI_DA-	Positive $V_{PSE}^a$
7	—	BI_DC+	Negative $V_{PSE}^b$	
8	—	BI_DC-	Negative $V_{PSE}^b$	

- a. Phantom supply  
b. Spare pair supply

## 1.5 Display elements

After the supply voltage is set up, the Software starts and initializes the device. Afterwards, the device performs a self-test. During this process, various LEDs light up.

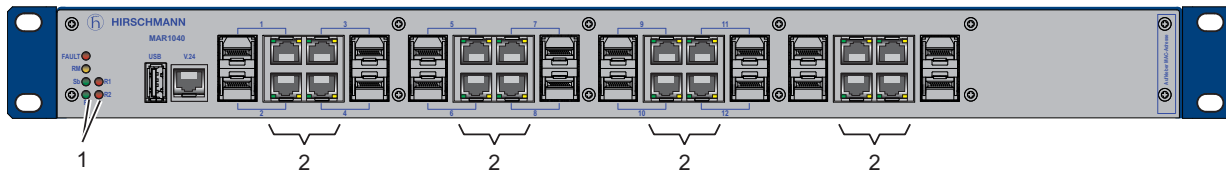

- 1 LED display elements device status
- 2 LED display elements port status

Table 6: Display elements of the MAR1040 and MAR1042 (ports on the front side of the device)

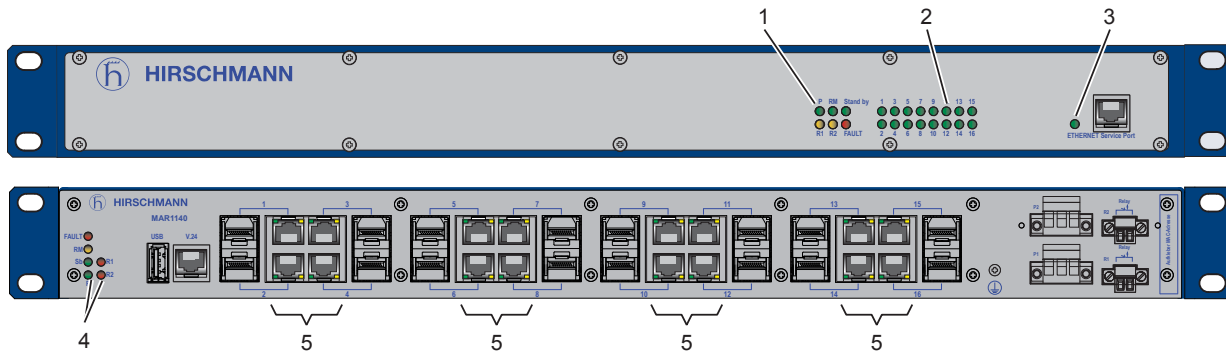

Front side of the device:

- 1 LED display elements device status
- 2 LED display elements port status for 16 × 1-Gigabit Ethernet ports
- 3 Diagnostic port with LED display element

Rear side of the device:

- 4 LED display elements device status
- 5 LED display elements port status

Table 7: Display elements of the MAR1140 and MAR1142 (ports on the rear side of the device)

### 1.5.1 Device state

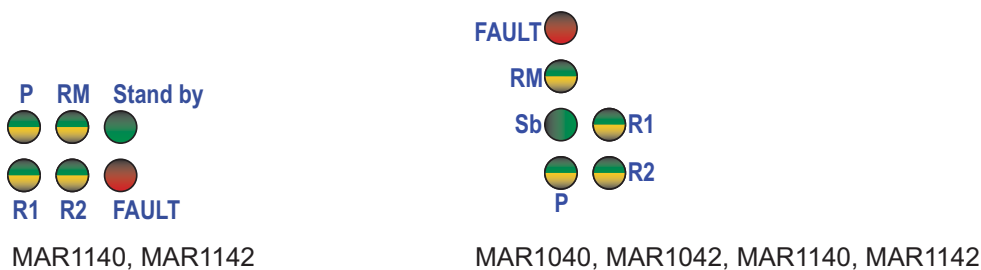

These LEDs provide information about conditions which affect the operation of the whole device.

The following table applies only to device variants with 2 power supply units:

LED	Display	Color	Activity	Meaning
P	Supply voltage	green	lights up	Supply voltage 1 <b>and</b> 2 is on
		yellow	lights up	Supply voltage 1 <b>or</b> 2 is on
		-	none	Supply voltages 1 <b>and</b> 2 are too low.

The following table applies only to device variants with one power supply unit:

LED	Display	Color	Activity	Meaning
P	Supply voltage	green	lights up	Supply voltage is on
		-	none	Supply voltage is too low

The following table applies to every device variant:

LED	Display	Color	Activity	Meaning
Stand-by/Sb	Stand-by mode	-	none	Stand-by mode not enabled
		green	lights up	Standby mode enabled
RM	Ring Manager	-	none	The RM function is deactivated.
		green	lights up	The RM function is active. The redundant port is disabled.
			flashing	The device detects an incorrect configuration of the HIPER-Ring (for example the ring is not connected to the ring port).
		yellow	lights up	The RM function is active. The redundant port is enabled.
RM and Stand-by/Sb	ACA memory operations	LED display elements RM and Stand-by/Sb	Flashing alternately	Error in the memory operation
			flashes synchronously 2 × per period	Saves a configuration file from the storage medium ACA to the device.
			flashes synchronously 1 × per period	Saves a configuration file from the device to the storage medium ACA.

Applies to software releases previous to 06.0.00:

LED	Display	Color	Activity	Meaning
FAULT	Signal contact 1	red	lights up	The signal contact is open - it is reporting a detected error.
			none	The signal contact is closed, it is <b>not</b> reporting any detected errors.

Applies to software release 06.0.00 and higher:

LED	Display	Color	Activity	Meaning
FAULT	Signal contact 1	red	lights up	The signal contact is open - it is reporting a detected error.
			none	The signal contact is closed, it is <b>not</b> reporting any detected errors.
	Duplicate IP detection	red	flashes 4 times a period	Reports an IP conflict.

Applies to software releases previous to 06.0.00:

LED	Display	Color	Activity	Meaning
R1	Signal contact 1	yellow	lights up	The signal contact is closed in manual operation.
			none	The signal contact is open in manual operation.
R2	Signal contact 2	yellow	lights up	The signal contact is closed in manual operation.
			none	The signal contact is open in manual operation.

Applies to software release 06.0.00 and higher:

LED	Display	Activity	Color	Meaning
R1	Signal contact 1	lights up	green	The signal contact is open in non-manual operation.
			yellow	The signal contact is open in manual operation.
			none	The signal contact is closed.
R2	Signal contact 2	lights up	green	The signal contact is open in non-manual operation.
			yellow	The signal contact is open in manual operation.
			none	The signal contact is closed.

If the manual setting is active on the signal contact “Relay”, then the error display is independent of the setting of the signal contact.

## 1.5.2 LED display elements port status

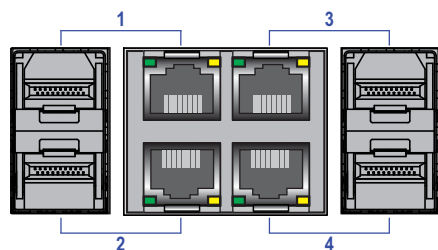

MAR1040, MAR1042, MAR1140, MAR1142



MAR1140, MAR1142



The green and yellow LEDs at the individual port display port-related information. During the boot phase, these LEDs are used to display the status of the boot procedure.

<b>LS, DA - link state, data (1 × green/yellow LED or 1 × green + 1 × yellow LED per port)</b>	
Not glowing	No valid connection
Glowing green	Valid connection
Flashing green (1 × a period)	Port is switched to stand-by
Flashing green (3 × a period)	Port is disabled
Flashing yellow	Receive data/send data

*Table 8: LED display elements port status: link state, data*

## 1.6 Management interfaces

### 1.6.1 V.24 interface (external management)

The V.24 interface is an RJ11 socket.

A serial interface is provided on the V.24 interface for the local connection of an external management station (VT100 terminal or PC with corresponding terminal emulation). This enables you to set up a connection to the Command Line Interface (CLI) and to the system monitor.

VT100 terminal settings	
Speed	9600 Baud
Data	8 bit
Stopbit	1 bit
Handshake	off
Parity	none

The interface casing is electrically connected to the front panel.  
The V.24 interface is not electrically insulated from the supply voltage.

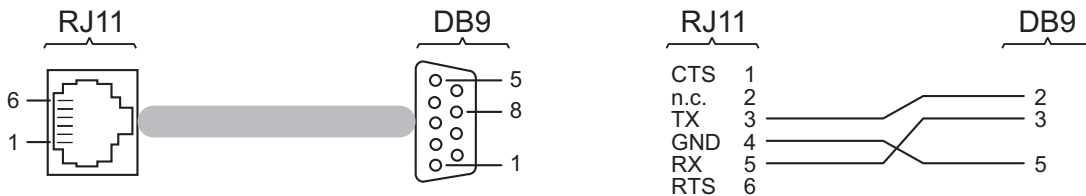

Figure 1: Pin assignment of the V.24 interface and the DB9 plug

**Note:** You will find the order number for the terminal cable, which is ordered separately, in the Technical Data section ([see on page 45 “Technical data”](#)).

You will find more information in the “Basic Configuration User Manual”.

The manual is available for download on the Internet: <https://www.doc.hirschmann.com>

### 1.6.2 USB interface

The USB interface allows you to connect the AutoConfiguration Adapter ACA22 storage medium. This is used for saving/loading the configuration data and diagnostic information, and for loading the software.

Figure	Pin	Function
	1	VCC (VBus)
	2	- Data
	3	+ Data
	4	Ground (GND)

Table 9: Pin assignment of the USB interface

## 1.7 Signal contact

Depending on the device variant (equipped with one or two power supply units), one or two signal contacts are available.

The signal contact is a potential-free relay contact.

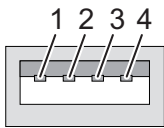
The device allows you to perform remote diagnosis via the signal contact. In the process, the device signals events such as a line interruption. When an event occurs, the device opens the relay contact and interrupts the closed circuit. The management setting specifies which events switch a contact. You can also use the management to switch the signal contact manually and thus control external devices.

- ▶ You can use the Management to set the signal contact manually and thus control external devices.

The potential-free signal contact (relay contact, closed circuit) reports through a break in contact:

- ▶ At least one power supply is inoperable.
- ▶ The device is not operational.
- ▶ The failure of the connection on at least one port.  
The report of the link status can be masked by the Management for each port. In the delivery state is deactivated.
- ▶ Loss of the ring redundancy reserve.
- ▶ A detected error during the self-test.
- ▶ Incorrect configuration of the HIPER-Ring or ring coupling.
- ▶ Permitted temperature range exceeded/not reached.

The following condition is also reported in RM mode:

- ▶ Ring redundancy reserve is available. On delivery, there is no ring redundancy monitoring.

**Note:** The signal contact functions are available when the power supply is connected. If a redundant power supply is present but switched off, contact interruption occurs at the associated signal contact.

## 2 Installation

The devices have been developed for practical application in a harsh industrial environment.

On delivery, the device is ready for operation.

Perform the following steps to install and configure the device:

- ▶ [Checking the package contents](#)
- ▶ [Installing an SFP transceiver \(optional\)](#)
- ▶ [Wiring of the terminal blocks for supply voltage and signal contact](#)
- ▶ [Installing and grounding the device](#)
- ▶ [Operating the device](#)
- ▶ [Connecting data cables](#)

### 2.1 Checking the package contents

- Check whether the package includes all items named in the section [“Scope of delivery”](#) on page 56.
- Check the individual parts for transport damage.

### 2.2 Installing an SFP transceiver (optional)

#### Prerequisites:

Exclusively use Hirschmann SFP transceivers.

[See “Accessories”](#) on page 57.

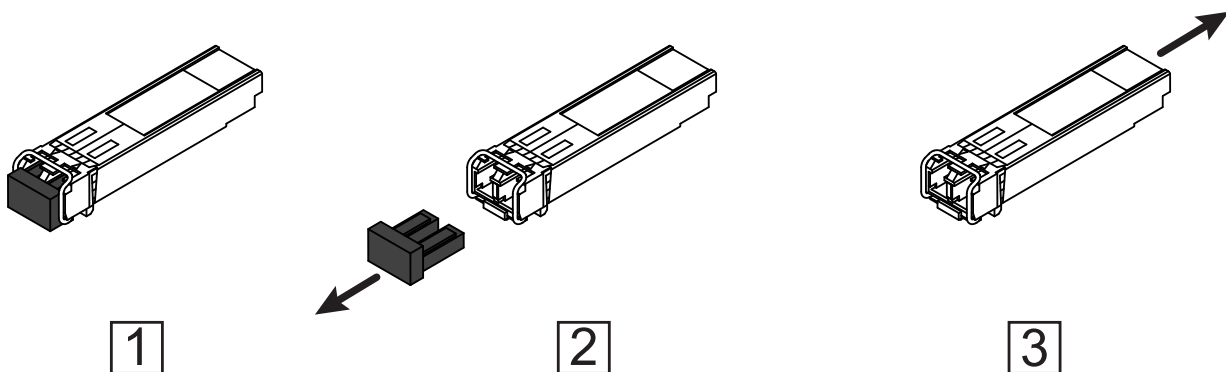

Figure 2: Installing SFP transceivers: Installation sequence



### Proceed as follows:

- Take the SFP transceiver out of the transport packaging (1).
- Remove the protection cap from the SFP transceiver (2).
- Push the SFP transceiver with the lock closed into the slot until it latches in (3).

## 2.3 Wiring of the terminal blocks for supply voltage and signal contact

The supply voltage is electrically isolated from the casing.

The voltage supply is connected via a 3-pin terminal block with screw locking.

The signal contact is connected via a 2-pin terminal block with screw locking (1 × or 2 ×, depending on device variant).

For device variants without PoE: The supply voltage in MACH1040/MACH1140 device variants can be connected redundantly with 2 power supply units. Both inputs are uncoupled.

### ■ MACH1040 device variants without PoE

MACH1040 device variants without Power over Ethernet (PoE) are, depending on the device variant, equipped with 1 or 2 power supply units of the following characteristic value.

- ▶ Power supply characteristic value L
- ▶ Power supply characteristic value M

[See “General technical data” on page 45.](#)

For devices without PoE featuring 2 power supply units, you can connect the supply voltage redundantly. Both inputs are uncoupled. With a non-redundant supply of the supply voltage, the device reports the loss of a supply voltage. You can prevent this message by applying the supply voltage via both inputs, or by changing the configuration in the Management.

### ■ MACH1040 devices with PoE

MACH1040 device variants with Power over Ethernet (PoE) are equipped with 2 power supply units.

- ▶ Power supply unit 1 is freely selectable from the combination table.
- ▶ Power supply unit 2 is a PoE power supply unit.

[See “Combination options” on page 18.](#)

**Note:** In the device variants MAR1042 and MAR1142, power supply unit 2 is exclusively a PoE power supply unit. A redundant power supply of the basic device is not possible.

### 2.3.1 Connecting the supply voltage

## **WARNING**

### **ELECTRIC SHOCK**

Connect only a supply voltage that corresponds to the type plate of your device.

**Failure to follow these instructions can result in death, serious injury, or equipment damage.**



**Note:** Observe the permitted voltage ranges for devices with certification characteristic value T (EN 50155 Railway (train)).  
See [“General technical data” on page 45](#).

Relevant for North America:

The torque for tightening the supply voltage terminal block on the device is 0.51 Nm (4.5 lb-in).

The terminal blocks for devices with power supply unit characteristic value M or L are coded to prevent them from being accidentally connected to devices with power supply unit characteristic value L or M.

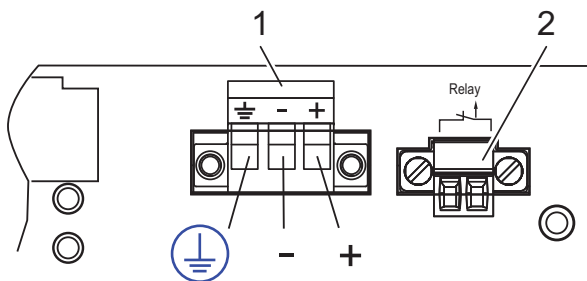

**Figure 3:** Power supply unit supply voltage characteristic value L, DC voltage (see on page 45 [“General technical data”](#))

Connecting

1 - Supply voltage

2 - Signal contact

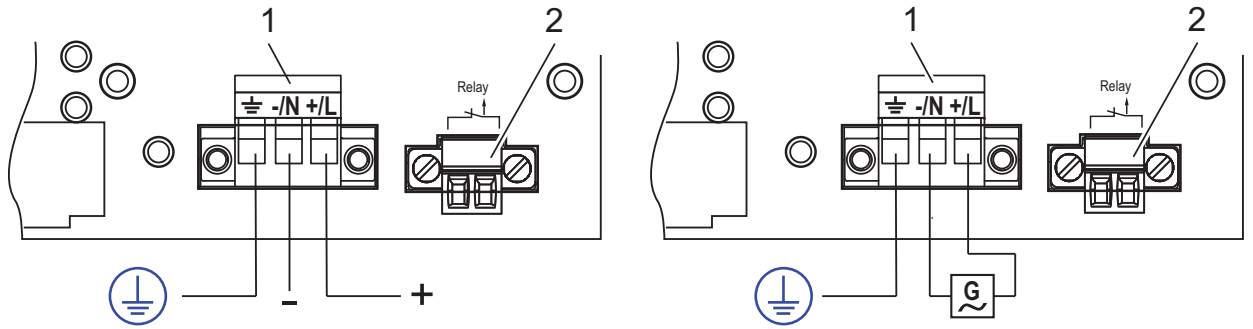

Figure 4: Power supply unit supply voltage characteristic value M (see on page 45 “General technical data”):

AC voltage (right figure) or DC voltage (left figure)

Connecting

1 - Supply voltage

2 - Signal contact

Connection	Power supply characteristic value L	Power supply characteristic value M - V DC	Power supply characteristic value M - V AC
⏚, pin 1	Protective conductor	Protective conductor	Protective conductor
-/N, pin 2	Minus terminal of the supply voltage	Minus terminal of the supply voltage	Neutral conductor
+/L, pin 3	Plus terminal of the supply voltage	Plus terminal of the supply voltage	Line conductor

Table 10: Pin assignment of terminal block for voltage supply

For **every** supply voltage to be connected, perform the following steps:

- Verify the required conditions for connecting the voltage supply.  
See “Supply voltage” on page 9.
- Remove the terminal connector from the device.
- Connect the protective conductor with the clamp.
- Connect the wires according to the pin assignment on the device with the clamps.
- Mount the terminal block on the device using screws.

### 2.3.2 Wiring the signal contact

Relevant for North America:

The torque for tightening the terminal block for the signal contact on the device is 3 lb-in (0.34 Nm).

**Note:** Use copper wire with cross-section AWG 20 to AWG 12 (0.5 mm<sup>2</sup> to 3.0 mm<sup>2</sup>) and stripping length 12 mm.

For every signal contact to be connected, make sure the following requirements are met:

- ▶ The electrical wires are voltage-free.
- ▶ The connected voltage is limited by a current limitation device or a fuse. Observe the electrical threshold values for the signal contact.  
See [“General technical data” on page 45.](#)

Perform the following steps for the signal contacts to be connected:

- Connect the signal contact lines with the terminal block connections.
- Mount the terminal block on the device using screws.

## 2.4 Installing and grounding the device

### **WARNING**

#### **ELECTRIC SHOCK**

Exclusively install this device in a switch cabinet or in a restricted access location according to IEC/EN 62368-1, to which maintenance staff have exclusive access.

**Failure to follow these instructions can result in death, serious injury, or equipment damage.**

**Note:** The shielding ground of the connectable twisted pair cables is connected to the front panel as a conductor.

### 2.4.1 Mounting in a switch cabinet

Install the device in the 19" switch cabinet using sliding or mounting rails. This provides a more stable position of your device in environments subject to vibration.

For more information on sliding/mounting rails and how to install them, please contact your switch cabinet manufacturer.

The devices are designed to be mounted in a 19" switch cabinet.

- Ensure adequate ventilation. If necessary, install an additional fan in the switch cabinet to prevent the device from overheating.
- Measure the depth of the 19" cabinet so that all the lines to be connected can be fed in easily.
- Assemble the sliding or mounting rails in the 19" switch cabinet as specified by the manufacturer.

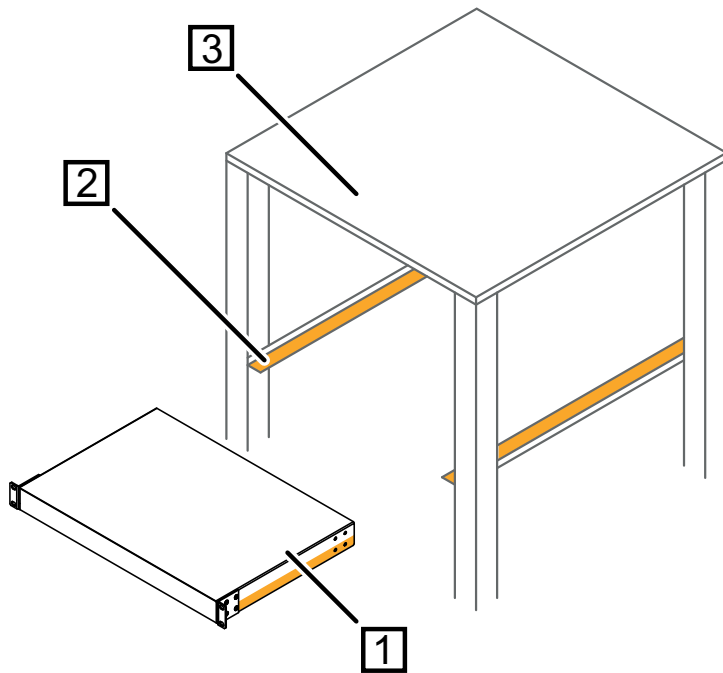

*Figure 5: Assembly in a switch cabinet with sliding/mounting rails*  
 1 - MACH1040 device  
 2 - sliding/mounting rail  
 3 - 19" switch cabinet

On delivery, 2 mounting brackets are mounted to the sides of the device (see figure below).

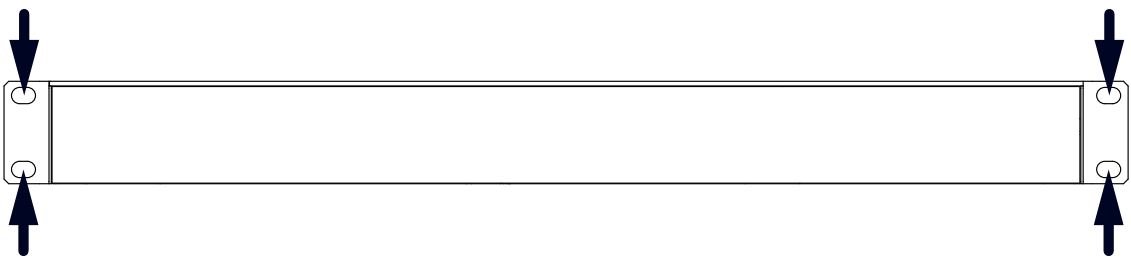

*Figure 6: Mounting in the switch cabinet*

- Fasten the device in the switch cabinet by screwing it in with the mounting brackets.

**Note:** When operating the device in an environment with strong vibrations, you have the option to additionally fasten the device to the switch cabinet using 2 holding brackets on the back of the device.

You obtain the additional brackets as accessories.

See [“Accessories” on page 57.](#)

## 2.4.2 Vertical mounting on the wall

### **WARNING**

#### **FIRE HAZARD**

Install the device in a fire enclosure according to IEC/EN 62368-1 if you install the device vertically.

**Failure to follow these instructions can result in death, serious injury, or equipment damage.**

- Move the two pre-installed mounting brackets into the position shown below.

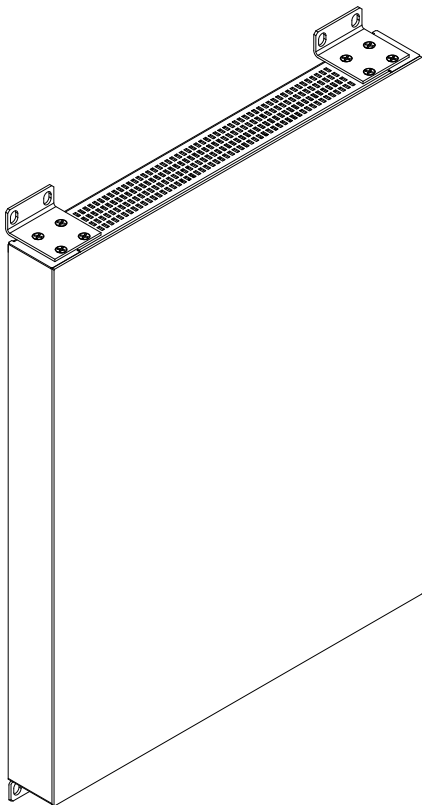

- Additionally attach 2 brackets to the back of the device. You obtain the additional brackets as accessories. See [“Accessories” on page 57](#).
- Fasten the device by screwing the brackets to the wall.

## 2.4.3 Grounding the device

The device is grounded via the separate grounding screw on the back of the device.

## 2.5 Operating the device

When you connect the supply voltage, you start up the device.

## 2.6 Connecting data cables

You can connect end devices and other segments to the device ports using twisted pair cables or optical fibers (F/O).

### 2.6.1 Twisted Pair ports

Note the following general recommendations for data cable connections in environments with high electrical interference levels:

- Keep the length of the data cables as short as possible.
- Use optical data cables for the data transmission between the buildings.
- When using copper cables, provide a sufficient separation between the power supply cables and the data cables. Ideally, install the cables in separate cable channels.
- Verify that power supply cables and data cables do not run parallel over longer distances. To reduce inductive coupling, verify that the power supply cables and data cables cross at a 90° angle.
- Use shielded data cables for gigabit transmission via copper cables, for example SF/UTP cables according to ISO/IEC 11801. Exclusively use shielded data cables to meet EMC requirements according to EN 50121-4 and marine applications.
- Connect the data cables according to your requirements.  
[See “10/100/1000 Mbit/s twisted pair port” on page 24.](#)

### 2.6.2 Optical fiber ports

Verify that you connect LH ports only with LH ports, SX ports only with SX ports, and LX ports only with LX ports.

- Connect the data cables according to your requirements.  
[See “100/1000 Mbit/s F/O port” on page 25.](#)

### 3 Making basic settings

The IP parameters must be entered when the device is installed for the first time. The device provides the following options for configuring IP addresses:

- ▶ Input via the V.24 interface
- ▶ Input via the HiView or Industrial HiVision application. You find further information about the applications HiView or Industrial HiVision on the Internet at the Hirschmann product pages:

#### HiView

<http://www.hirschmann.com/en/QR/INET-HiView>

#### Industrial HiVision

<http://www.hirschmann.com/en/QR/INET-Industrial-HiVision>

- ▶ Configuration via BOOTP
- ▶ Configuration via DHCP (Option 82)
- ▶ AutoConfiguration Adapter

You will find more information in the “Basic Configuration User Manual”.

The manual is available for download on the Internet: [https://](https://www.doc.hirschmann.com)

[www.doc.hirschmann.com](https://www.doc.hirschmann.com)

#### ■ Default settings

- ▶ IP address: The device looks for the IP address using DHCP
- ▶ Password for management:
  - Login: user; password: public (read only)
  - Login: admin; password: private (read and write)
- ▶ Parameters that can be set via the management are set to pre-defined values in accordance with the MIB
- ▶ V.24 data rate: 9600 Baud
- ▶ Ring redundancy: disabled
- ▶ Ethernet ports: link status is not evaluated (signal contact)
- ▶ Optical 100 Mbit/s ports: 100 Mbit/s full duplex
- ▶ All other ports: autonegotiation
- ▶ Ring manager disabled
- ▶ Stand-by coupling: disabled
- ▶ Port 4 = control port, port 3 = coupling port for red. Ring coupling



## 3.1 First login (Password change)

To help prevent undesired access to the device, it is imperative that you change the default password during initial setup.

Perform the following steps:

- Open the Graphical User Interface, the Command Line Interface, or HiView the first time you log on to the device.
- Log on to the device with the default password “private”. The device prompts you to type in a new password.
- Type in your new password.  
To help increase security, choose a password that contains at least 8 characters which includes upper-case characters, lower-case characters, numerical digits, and special characters.
- When you log on to the device with the Command Line Interface, then the device prompts you to confirm your new password.
- Log on to the device again with your new password.

**Note:** If you lost your password, then use the System Monitor to reset the password.

For further information see:

<https://hirschmann-support.belden.com/en/kb/required-password-change-new-procedure-for-first-time-login>

## 4 Monitoring the ambient air temperature

Operate the device below the specified maximum ambient air temperature exclusively.

See [“General technical data” on page 45](#).

The ambient air temperature is the temperature of the air at a distance of 2 in (5 cm) from the device. It depends on the installation conditions of the device, for example the distance from other devices or other objects, and the output of neighboring devices.

The temperature displayed in the CLI and the GUI is the internal temperature of the device. It is higher than the ambient air temperature. The maximum internal temperature of the device named in the technical data is a guideline that indicates to you that the maximum ambient air temperature has possibly been exceeded.

## 5 Maintenance and service

- When designing this device, Hirschmann largely avoided using high-wear parts. The parts subject to wear and tear are dimensioned to last longer than the lifetime of the product when it is operated normally. Operate this device according to the specifications.
- Relays are subject to natural wear. This wear depends on the frequency of the switching operations. Check the resistance of the closed relay contacts and the switching function depending on the frequency of the switching operations.
- Hirschmann is continually working on improving and developing their software. Check regularly whether there is an updated version of the software that provides you with additional benefits. You find information and software downloads on the Hirschmann product pages on the Internet (<http://www.hirschmann.com>).
- Depending on the degree of pollution in the operating environment, check at regular intervals that the ventilation slots in the device are not obstructed.

**Note:** You find information on settling complaints on the Internet at <http://www.beldensolutions.com/en/Service/Repairs/index.phtml>.

## 6 Disassembly

### 6.1 Removing the device

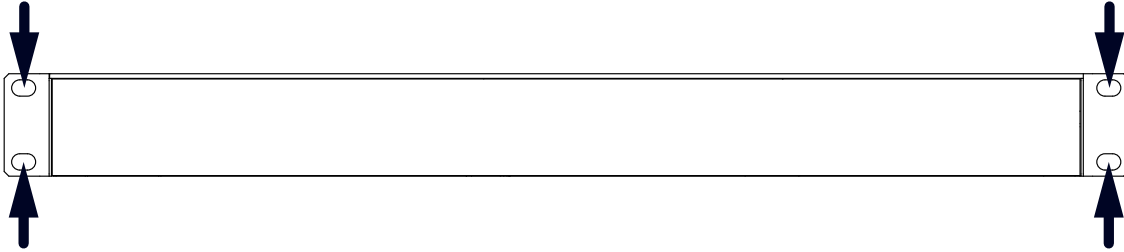

Proceed as follows:

- Disconnect the data cables.
- Disable the supply voltage.
- Disconnect the grounding.
- To detach the device from the switch cabinet or the wall, remove the screws from the brackets on the device.

### 6.2 Removing an SFP transceiver (optional)

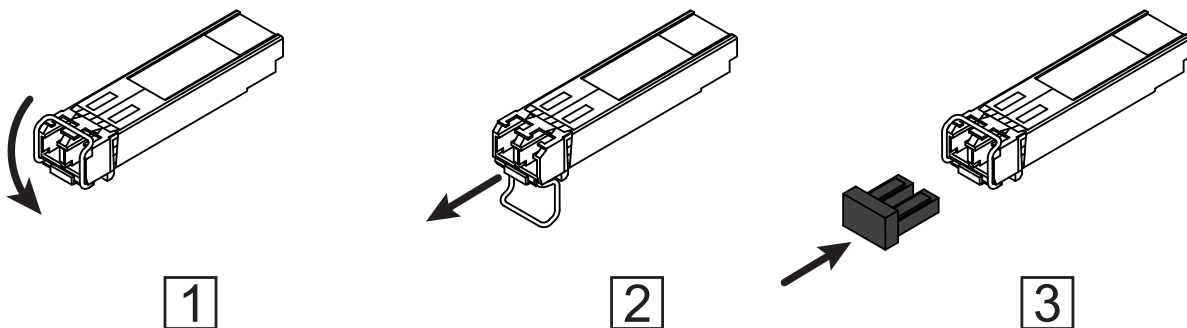

Figure 7: De-installing SFP transceivers: De-installation sequence

Proceed as follows:

- Open the locking mechanism of the SFP transceiver (1).
- Pull the SFP transceiver out of the slot via the open locking mechanism (2).
- Close the SFP transceiver with the protection cap (3).

# 7 Technical data

## 7.1 General technical data

Dimensions W × H × D	MAR1...	448 mm × 345 mm × 44 mm (17.64 in × 13.58 in × 1.73 in) (without brackets)
		463 mm × 345 mm × 44 mm (18.23 in × 13.58 in × 1.73 in) (with brackets)
Weight	MAR1040..., MAR1140...	max. 4.2 kg (9.3 lb)
	MAR1040..., MAR1140... devices with redundant power supply unit	max. 4.4 kg (9.7 lb)
	MAR1042..., MAR1142... devices with PoE power supply unit	max. 4.6 kg (10.2 lb)
Power supply Characteristic value M	Rated voltage range	100 V AC ... 240 V AC, 50 Hz ... 60 Hz
	Voltage range including maximum tolerances	90 V AC ... 265 V AC, 47 Hz ... 63 Hz
	Rated voltage range	110 V DC ... 250 V DC
	Voltage range including maximum tolerances	77 V DC ... 300 V DC
	Connection type	3-pin terminal block
	Power loss buffer	>20 ms at 230 V AC
	Back-up fuse	Nominal rating: 2.5 A
		Characteristic: slow blow
Peak inrush current	14 A	
Power supply Characteristic value L	Rated voltage range	24 V DC ... 48 V DC
	Voltage range including maximum tolerances	18 V DC ... 60 V DC
	Connection type	3-pin terminal block
	Power loss buffer	>10 ms at 20.4 V DC
	Back-up fuse	Nominal rating: 6.3 A
		Characteristic: slow blow
Peak inrush current	15 A	
Signal contact (non-hazardous locations)	Nominal value	$I_{\max} = 2 \text{ A}$ at $U_{\max} = 230 \text{ V AC}$
		$I_{\max} = 2 \text{ A}$ at $U_{\max} = 30 \text{ V DC}$
		$I_{\max} = 0.2 \text{ A}$ at $U_{\max} = 125 \text{ V DC}$
Connection type	2-pin terminal block	$I_{\max} = 0.1 \text{ A}$ at $U_{\max} = 250 \text{ V DC}$
Signal contact (Hazardous Locations Class 1, Division 2)	Electrical parameters	$V_{\max} = 30 \text{ V}$
		$I_{\max} = 90 \text{ mA}$
		$C_i = 50 \text{ pF}$
		$L_i = 2 \text{ } \mu\text{H}$
	Connection type	2-pin terminal block
		<a href="#">See "Use in Hazardous Locations" on page 11.</a>

Climatic conditions during operation	Minimum clearance around the device	Top and bottom sides of device: 1.97 in (5 cm) Left and right device side: 3.94 in (10 cm)
	Ambient air temperature <sup>a</sup> .	Standard: 0 °C ... +60 °C (+32 °F ... +140 °F) <sup>b</sup> Extended: -40 °C ... +70 °C (-40 °F ... +158 °F) <sup>b</sup>
	Humidity	5 % ... 95 % (non-condensing)
	Air pressure	up to 6562 ft (2000 m; 795 hPa) higher altitudes upon request
Climatic conditions during storage	Ambient air temperature <sup>a</sup>	Extended: -40 °C ... +70 °C (-40 °F ... +158 °F) Extended: -40 °C ... +85 °C (-40 °F ... +185 °F) <sup>b</sup>
	Humidity	5 % ... 95 % (non-condensing)
	Air pressure	up to 6562 ft (2000 m; 795 hPa), higher altitudes upon request
Pollution degree		2
Protection classes	Laser protection Protection class	Class 1 according to EN 60825-1 IP30

- a. Temperature of the ambient air at a distance of 2 in (5 cm) from the device
- b. If you are using SFP modules without the “EEC” extension, an operating temperature of 0 °C ... +55 °C (+32 °F ... +131 °F) (see on page 57 “Accessories”) applies to your device.

## 7.2 Dimension drawings

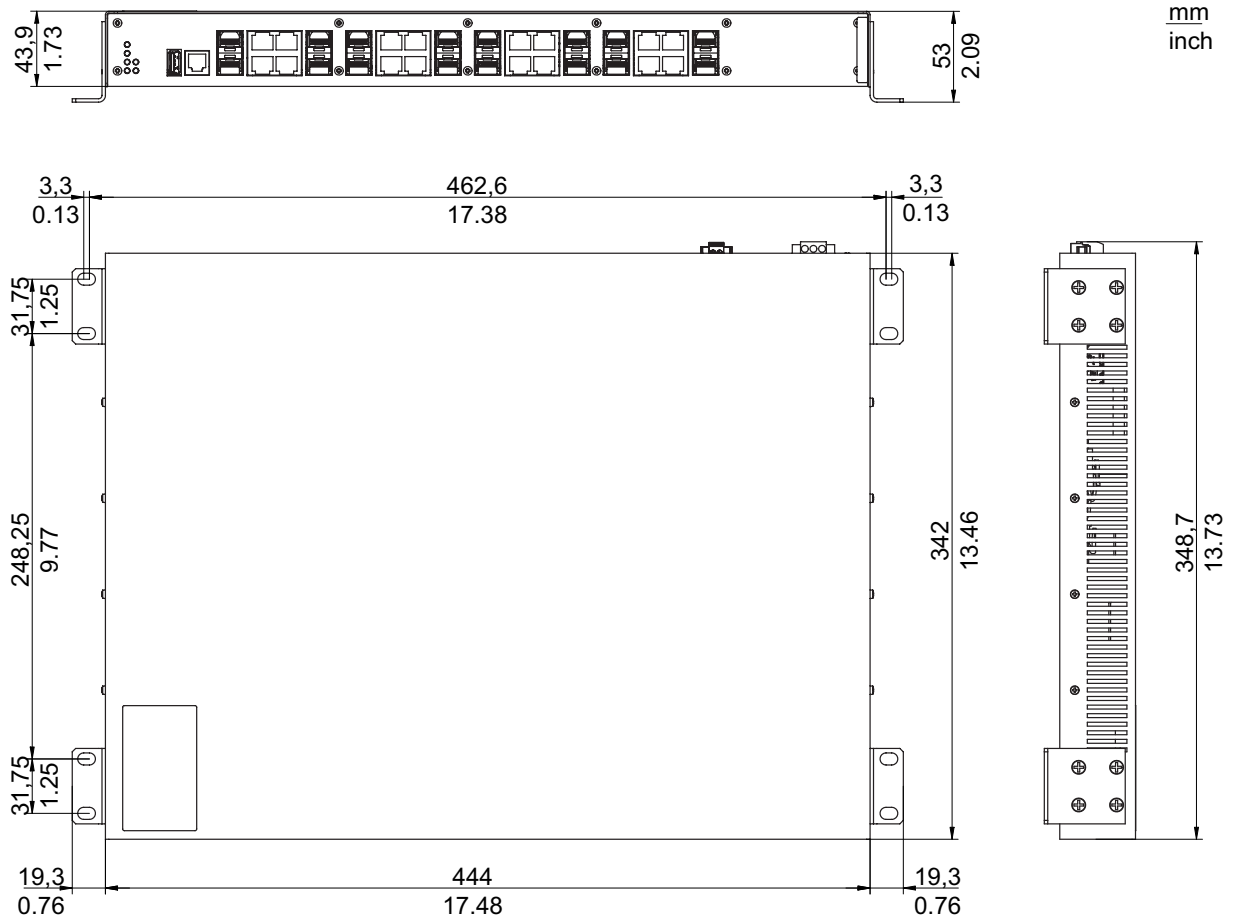

Figure 8: Dimensions for mounting on a flat surface

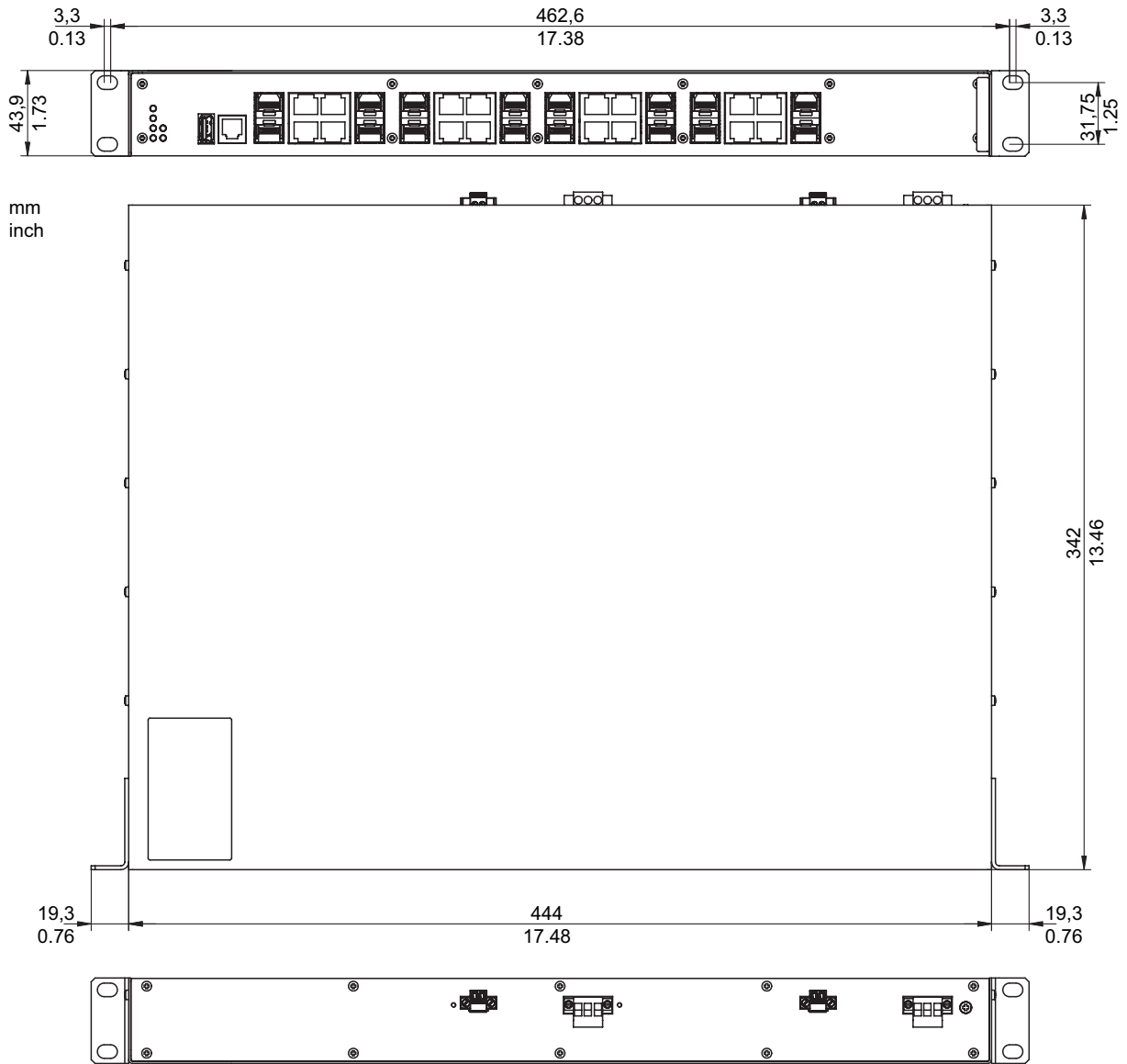

Figure 9: Dimensions for mounting in a switch cabinet



## 7.3 EMC and immunity

EMC interference immunity IEC/EN 61850-3 EMI TYPE test, test according to	Description	Test level
IEC/EN 61000-4-2	Electrostatic discharge	
	Contact discharge	±8 kV
	Air discharge	±15 kV
IEC/EN 61000-4-3	Electromagnetic field	
	80 MHz ... 2700 MHz	20 V/m
IEC/EN 61000-4-4	Fast transients (burst)	
	DC Power Line	±4 kV
	AC Power Line	±4 kV
	Data line	±4 kV
IEC/EN 61000-4-5	Voltage surges	
	DC Power Line	±2 kV line/ground; ±1 kV line/line
	AC Power Line	±4 kV line/ground; ±2 kV line/line
	Data line	±4 kV line/ground
IEC/EN 61000-4-6	Conducted disturbances	
	150 kHz ... 80 MHz	10 V
IEC/EN 61000-4-12	Damped oscillation	
	DC Power Line	±2,5 kV line/earth; ±1 kV line/line
	AC Power Line	±2,5 kV line/earth; ±1 kV line/line
	Data line	±2,5 kV line/earth; ±1 kV line/line
IEC 60255-5	dielectric strength	
	DC power line - Power supply unit supply voltage characteristic value L	500 V AC 500 V AC
	AC power line - Power supply unit supply voltage characteristic value M	2000 V AC 2000 V AC
	DC power line - Power supply unit supply voltage characteristic value M	2000 V AC
	Signal contact supply voltage characteristic value L and M	2000 V AC

EMC interference immunity IEEE 1613 EMI TYPE test, test according to	Description	Test level
IEEE C37.90.3	Electrostatic discharge	
	Contact discharge	±8 kV
	Air discharge	±15 kV
IEEE C37.90.2	Electromagnetic field	
	80 MHz ... 1000 MHz	35 V/m (peak)

<b>EMC interference immunity IEEE 1613 EMI TYPE test, test according to</b>	<b>Description</b>	<b>Test level</b>
IEEE C37.90.1	Fast transients (burst)	
	DC Power Line	±4 kV
	AC Power Line	±4 kV
	Data line	±4 kV
IEEE C37.90.1	Damped oscillation	
	DC Power Line	±2,5 kV line/earth; ±1 kV line/line
	AC Power Line	±2,5 kV line/earth; ±1 kV line/line
	Data line	±2,5 kV line/earth; ±1 kV line/line
IEEE C37.90	H.V. Impulse	
	DC Power Line	± 5 kV line/earth
	AC Power Line	± 5 kV line/earth
IEEE C37.90	dielectric strength	
	DC power line - Power supply unit supply voltage characteristic value L	500 V AC
	AC power line - Power supply unit supply voltage characteristic value M	2000 V AC
	DC power line - Power supply unit supply voltage characteristic value M	2000 V AC
	Signal contact supply voltage characteristic value L and M	2000 V AC

<b>EMC interference emission</b>	
EN 55032	Class A
FCC 47 CFR Part 15	Class A
German Lloyd	Classification + Construction Guidelines VI-7-3 Part 1 Ed. 2001

<b>Environment TYPE test, test according to</b>	<b>Description</b>	<b>Test level</b>
IEC 60068-2-1	Cold	-40 °F (-40 °C), 16 hours
IEC 60068-2-2	Dry heat	+185 °F (+85 °C), 16 hours
IEC 60068-2-30	Relative humidity	95 % (non condensing) 131 °F (55 °C), 4 cycles
IEC 60068-2-6	Vibration, test Fc	2 - 9 Hz with 3 mm amplitude 1 g at 9 - 150 Hz 1.5 g at 200 - 500 Hz
IEC 60068-2-27	Shock, test Ea	15 g at 11 ms

## 7.4 Network range

**Note:** The line lengths specified for the transceivers apply for the respective fiber data (fiber attenuation and Bandwidth Length Product (BLP)/ Dispersion).

### 7.4.1 10/100/1000 Mbit/s twisted pair port

10/100/1000 Mbit/s twisted pair port	
Length of a twisted pair segment	max. 328 ft (100 m) (for Cat5e cable)

Table 11: Network range: 10/100/1000 Mbit/s twisted pair port

### 7.4.2 Fast Ethernet SFP transceiver

Product code	Mode <sup>a</sup>	Wave length	Fiber	System attenuation	Example for F/O line length <sup>b</sup>	Fiber attenuation	BLP/Dispersion
M-FAST-SFP-MM/LC...	MM	1310 nm	50/125 μm	0 dB ... 8 dB	0 mi ... 3.11 mi (0 km ... 5 km)	1.0 dB/km	800 MHz×km
M-FAST-SFP-MM/LC...	MM	1310 nm	62.5/125 μm	0 dB ... 11 dB	0 mi ... 2.49 mi (0 km ... 4 km)	1.0 dB/km	500 MHz×km
M-FAST-SFP-SM/LC...	SM	1310 nm	9/125 μm	0 dB ... 13 dB	0 mi ... 15.53 mi (0 km ... 25 km)	0.4 dB/km	3.5 ps/(nm×km)
M-FAST-SFP-SM+/LC...	SM	1310 nm	9/125 μm	10 dB ... 29 dB	15.53 mi ... 40.39 mi (25 km ... 65 km)	0.4 dB/km	3.5 ps/(nm×km)
M-FAST-SFP-LH/LC...	SM	1550 nm	9/125 μm	10 dB ... 29 dB	29.20 mi ... 64.62 mi (47 km ... 104 km)	0.25 dB/km	19 ps/(nm×km)
M-FAST-SFP-LH/LC...	SM	1550 nm	9/125 μm	10 dB ... 29 dB	14.29 mi ... 86.99 mi (55 km ... 140 km)	0.18 dB/km <sup>c</sup>	18 ps/(nm×km)
SFP-FAST-MM/LC <sup>d</sup>	MM	1310 nm	50/125 μm	0 dB ... 8 dB	0 mi ... 3.11 mi (0 km ... 5 km)	1.0 dB/km	800 MHz×km

Table 12: F/O port 100BASE-FX (SFP Fiber Optic Fast Ethernet Transceiver)

Product code	Mode <sup>a</sup>	Wave length	Fiber	System attenuation	Example for F/O line length <sup>b</sup>	Fiber attenuation	BLP/Dispersion
SFP-FAST-MM/LC EEC <sup>d</sup>	MM	1310 nm	62.5/125 µm	0 dB ... 11 dB	0 mi ... 2.49 mi (0 km ... 4 km)	1.0 dB/km	500 MHz×km
SFP-FAST-SM/LC <sup>d</sup>	SM	1310 nm	9/125 µm	0 dB ... 13 dB	0 mi ... 15.53 mi (0 km ... 25 km)	0.4 dB/km	3.5 ps/(nm×km)
SFP-FAST-SM/LC EEC <sup>d</sup>	SM	1310 nm	9/125 µm	0 dB ... 13 dB	0 mi ... 15.53 mi (0 km ... 25 km)	0.4 dB/km	3.5 ps/(nm×km)

Table 12: F/O port 100BASE-FX (SFP Fiber Optic Fast Ethernet Transceiver)

- a. MM = Multimode, SM = Singlemode, LH = Singlemode Longhaul  
b. Including 3 dB system reserve when compliance with the fiber data is observed.  
c. With ultra-low-loss optical fiber.  
d. You will find further information on certifications on the Internet on the Hirschmann product pages ([www.hirschmann.com](http://www.hirschmann.com)).

### 7.4.3 Bidirectional Fast Ethernet SFP transceiver

Product code	Mode <sup>a</sup>	Wave length TX	Wave length RX	Fiber	System attenuation	Example for F/O line length <sup>b</sup>	Fiber attenuation	BLP/Dispersion
SFP-FAST-BA MM/LC EEC	MM	1310 nm	1550 nm	50/125 µm 62.5/125 µm	0 dB ... 16 dB	0 mi ... 1.24 mi (0 km ... 2 km)	1.0 dB/km	800 MHz×km 500 MHz×km
SFP-FAST-BB MM/LC EEC	MM	1550 nm	1310 nm	50/125 µm 62.5/125 µm	0 dB ... 16 dB	0 mi ... 1.24 mi (0 km ... 2 km)	1.0 dB/km	800 MHz×km 500 MHz×km
SFP-FAST-BA SM/LC EEC	SM	1310 nm	1550 nm	9/125 µm	0 dB ... 18 dB	0 km ... 12.43 mi (0 km ... 20 km)	0.4 dB/km	3.5 ps/(nm×km)
SFP-FAST-BB SM/LC EEC	SM	1550 nm	1310 nm	9/125 µm	0 dB ... 18 dB	0 km ... 12.43 mi (0 km ... 20 km)	0.25 dB/km	19 ps/(nm×km)
SFP-FAST-BA SM+/LC EEC	SM	1310 nm	1550 nm	9/125 µm	0 dB ... 29 dB	0 mi ... 37.29 mi (0 km ... 60 km)	0.4 dB/km	3.5 ps/(nm×km)
SFP-FAST-BB SM+/LC EEC	SM	1550 nm	1310 nm	9/125 µm	0 dB ... 29 dB	0 mi ... 37.29 mi (0 km ... 60 km)	0.25 dB/km	19 ps/(nm×km)

Table 13: F/O port (bidirectional Fast Ethernet SFP transceiver)

- a. MM = Multimode, SM = Singlemode, LH = Singlemode Longhaul

b. Including 3 dB system reserve when compliance with the fiber data is observed.

### 7.4.4 Gigabit Ethernet SFP transceiver

Product code	Mode <sup>a</sup>	Wave length	Fiber	System attenuation	Example for F/O line length <sup>b</sup>	Fiber attenuation	BLP/Dispersion
M-SFP-SX/LC...	MM	850 nm	50/125 μm	0 dB ... 7.5 dB	0 mi ... 0.34 mi (0 km ... 0.55 km)	3.0 dB/km	400 MHz×km
M-SFP-SX/LC...	MM	850 nm	62.5/125 μm	0 dB ... 7.5 dB	0 mi ... 0.17 mi (0 km ... 0.275 km)	3.2 dB/km	200 MHz×km
M-SFP-MX/LC...	MM	1310 nm	50/125 μm	0 dB ... 12 dB	0 mi ... 0.93 mi (0 km ... 1.5 km)	1.0 dB/km	800 MHz×km
M-SFP-MX/LC...	MM	1310 nm	62.5/125 μm	0 dB ... 12 dB	0 mi ... 31.06 mi (0 km ... 50 km)	1.0 dB/km	500 MHz×km
M-SFP-LX/LC...	MM	1310 nm <sup>c</sup>	50/125 μm	0 dB ... 10.5 dB	0 mi ... 0.34 mi (0 km ... 0.55 km)	1.0 dB/km	800 MHz×km
M-SFP-LX/LC...	MM	1310 nm <sup>d</sup>	62.5/125 μm	0 dB ... 10.5 dB	0 mi ... 0.34 mi (0 km ... 0.55 km)	1.0 dB/km	500 MHz×km
M-SFP-LX/LC...	SM	1310 nm	9/125 μm	0 dB ... 10.5 dB	0 mi ... 12.43 mi (0 km ... 20 km) <sup>e</sup>	0.4 dB/km	3.5 ps/(nm×km)
M-SFP-LX+/LC...	SM	1310 nm	9/125 μm	5 dB ... 20 dB	8.70 mi ... 26.10 mi (14 km ... 42 km)	0.4 dB/km	3.5 ps/(nm×km)
M-SFP-LH/LC...	LH	1550 nm	9/125 μm	5 dB ... 22 dB	14.29 mi ... 49.71 mi (23 km ... 80 km)	0.25 dB/km	19 ps/(nm×km)
M-SFP-LH+/LC	LH	1550 nm	9/125 μm	15 dB ... 30 dB	44.12 mi ... 67.11 mi (71 km ... 108 km)	0.25 dB/km	19 ps/(nm×km)
M-SFP-LH+/LC	LH	1550 nm	9/125 μm	15 dB ... 30 dB	44.12 mi ... 79.54 mi (71 km ... 128 km)	0.21 dB/km (typically)	19 ps/(nm×km)
M-SFP-LH+/LC EEC	LH	1550 nm	9/125 μm	13 dB ... 32 dB	38.52 mi ... 72.07 mi (62 km ... 116 km)	0.25 dB/km	19 ps/(nm×km)

Table 14: F/O port 1000BASE-FX (SFP fiber optic Gigabit Ethernet Transceiver)

Product code	Mode <sup>a</sup>	Wave length	Fiber	System attenuation	Example for F/O line length <sup>b</sup>	Fiber attenuation	BLP/Dispersion
M-SFP-LH+/LC EEC	LH	1550 nm	9/125 μm	13 dB ... 32 dB	38.52 mi ... 85.75 mi (62 km ... 138 km)	0.21 dB/km (typically)	19 ps/(nm×km)
SFP-GIG-LX/LC...	MM	1310 nm <sup>f</sup>	50/125 μm	0 dB ... 10.5 dB	0 mi ... 0.34 mi (0 km ... 0.55 km)	1.0 dB/km	800 MHz×km
SFP-GIG-LX/LC...	MM	1310 nm <sup>g</sup>	62.5/125 μm	0 dB ... 10.5 dB	0 mi ... 0.34 mi (0 km ... 0.55 km)	1.0 dB/km	500 MHz×km
SFP-GIG-LX/LC...	SM	1310 nm	9/125 μm	0 dB ... 10.5 dB	0 mi ... 12.43 mi (0 km ... 20 km) <sup>h</sup>	0.4 dB/km	3.5 ps/(nm×km)

Table 14: F/O port 1000BASE-FX (SFP fiber optic Gigabit Ethernet Transceiver)

- a. MM = Multimode, SM = Singlemode, LH = Singlemode Longhaul  
b. Including 3 dB system reserve when compliance with the fiber data is observed.  
c. With F/O adapter compliant with IEEE 802.3-2002 Clause 38 (single-mode fiber offset-launch mode conditioning patch cord).  
d. With F/O adapter compliant with IEEE 802.3-2002 Clause 38 (single-mode fiber offset-launch mode conditioning patch cord).  
e. Including 2.5 dB system reserve when compliance with the fiber data is observed.  
f. With F/O adapter compliant with IEEE 802.3-2002 Clause 38 (single-mode fiber offset-launch mode conditioning patch cord).  
g. With F/O adapter compliant with IEEE 802.3-2002 Clause 38 (single-mode fiber offset-launch mode conditioning patch cord).  
h. Including 2.5 dB system reserve when compliance with the fiber data is observed.

## 7.4.5 Bidirectional Gigabit Ethernet SFP transceiver

Product code	Mode <sup>a</sup>	Wave length TX	Wave length RX	Fiber	System attenuation	Example for F/O line length <sup>b</sup>	Fiber attenuation	BLP/Dispersion
M-SFP-BIDI Type A LX/LC EEC	SM	1310 nm	1550 nm	9/125 μm	0 dB ... 11 dB	0 km ... 12.43 mi (0 km ... 20 km)	0.4 dB/km	3.5 ps/(nm×km)
M-SFP-BIDI Type B LX/LC EEC	SM	1550 nm	1310 nm	9/125 μm	0 dB ... 11 dB	0 km ... 12.43 mi (0 km ... 20 km)	0.25 dB/km	19 ps/(nm×km)
M-SFP-BIDI Type A LH/LC EEC	LH	1490 nm	1590 nm	9/125 μm	5 dB ... 24 dB	14.29 mi ... 49.71 mi (23 km ... 80 km)	0.25 dB/km	19 ps/(nm×km)
M-SFP-BIDI Type B LH/LC EEC	LH	1590 nm	1490 nm	9/125 μm	5 dB ... 24 dB	14.29 mi ... 49.71 mi (23 km ... 80 km)	0.25 dB/km	19 ps/(nm×km)

Table 15: F/O port (bidirectional Gigabit Ethernet SFP transceiver)

Product code	Mode <sup>a</sup>	Wave length TX	Wave length RX	Fiber	System attenuation	Example for F/O line length <sup>b</sup>	Fiber attenuation	BLP/Dispersion
SFP-GIG-BA LX/LC EEC	SM	1310 nm	1550 nm	9/125 μm	0 dB ... 15 dB	0 km ... 12.43 mi (0 km ... 20 km)	0.4 dB/km	3.5 ps/(nm×km)
SFP-GIG-BB LX/LC EEC	SM	1550 nm	1310 nm	9/125 μm	0 dB ... 15 dB	0 km ... 12.43 mi (0 km ... 20 km)	0.25 dB/km	19 ps/(nm×km)
SFP-GIG-BA LX+/LC EEC	SM	1310 nm	1550 nm	9/125 μm	3 dB ... 20 dB	7.45 mi ... 24.86 mi (12 km ... 40 km)	0.4 dB/km	3.5 ps/(nm×km)
SFP-GIG-BB LX+/LC EEC	SM	1550 nm	1310 nm	9/125 μm	3 dB ... 20 dB	7.45 mi ... 24.86 mi (12 km ... 40 km)	0.25 dB/km	19 ps/(nm×km)
SFP-GIG-BA LH/LC EEC	LH	1490 nm	1550 nm	9/125 μm	4 dB ... 24 dB	11.80 mi ... 49.71 mi (19 km ... 80 km)	0.25 dB/km	19 ps/(nm×km)
SFP-GIG-BB LH/LC EEC	LH	1550 nm	1490 nm	9/125 μm	4 dB ... 24 dB	11.80 mi ... 49.71 mi (19 km ... 80 km)	0.25 dB/km	19 ps/(nm×km)

*Table 15: F/O port (bidirectional Gigabit Ethernet SFP transceiver)*

- a. MM = Multimode, SM = Singlemode, LH = Singlemode Longhaul
- b. Including 3 dB system reserve when compliance with the fiber data is observed.

## 7.5 Power consumption/power output

Device variants without PoE (MAR1040..., MAR1140...)	Maximum power consumption	Maximum power output
Device (without SFP modules, without TP links)	10 W	34 Btu (IT)/h
additionally for each connected SFP module	1 W	3 Btu (IT)/h
additionally for each TP port with link	0.8 W	3 Btu (IT)/h
Device at full capacity (16 links)	26 W	88 Btu (IT)/h

Device variants with PoE (MAR1042..., MAR1142...)	Maximum power consumption	Maximum power output
Device (without SFP modules, without TP links, without PDs)	10 W	34 Btu (IT)/h
additionally for each connected SFP module	1 W	3 Btu (IT)/h
additionally for each TP port with link	0.8 W	3 Btu (IT)/h
additionally for each TP port with link when one Class0-PD (powered device) is connected	19.5 W	12 Btu (IT)/h
Device at full capacity with 4 x Class0-PD (powered device) connected	100 W	136 Btu (IT)/h

## 7.6 Scope of delivery

Amount	Scope of delivery
1 ×	Safety and general information sheet
1 ×	Device
2 ×	Brackets with fastening screws (pre-mounted)
1 × or 2 × (depending on the device variant)	3-pin terminal block for the supply voltage
1 × or 2 × (depending on the device variant)	2-pin terminal block for signal contact

Table 16: Scope of delivery



## 7.7 Order numbers/product description

Combination options and device names (see table 1).

You can also order the following device variants using their order numbers:

Name	Description	Order number
MAR1040-4C4C4C4C9999SM9H PHH	MACH 1040 device with - 16 x Gigabit Ethernet combo ports - ports on front of device, power supply connection on back of device - standard temperature range - 1 power unit type M - Layer2 Professional software	942 004 - 001

## 7.8 Accessories

Note that products recommended as accessories may have different characteristics to those of the device, which may limit the application range of the overall system. For example, if you add an accessory with IP20 to a device with IP65, the degree of protection of the overall system is reduced to IP20.

Fast Ethernet SFP transceiver	Order number
M-FAST SFP-TX/RJ45	942 098-001
M-FAST SFP-TX/RJ45 EEC	942 098-002
The following operating conditions apply to twisted pair transceivers:	
▶ Usable with: - HiOS as of software version 03.0.00 - for PRP ports on RSP devices, as of software version 02.0.01 - for PRP ports on EES devices, as of software version 02.0.02 - Classic switch software as of software version 08.0.00 - HiSecOS as of software version 01.2.00	
▶ Longer RSTP switching times and link loss detection times compared to twisted pair ports provided by the device directly.	
▶ Not applicable for combo ports.	
▶ Not applicable for ports which support only Gigabit Ethernet.	
▶ It is currently not possible to set autocrossing manually.	
M-FAST SFP-MM/LC	943 865-001
M-FAST SFP-MM/LC EEC	943 945-001
M-FAST SFP-SM/LC	943 866-001
M-FAST SFP-SM/LC EEC	943 946-001
M-FAST SFP-SM+/LC	943 867-001
M-FAST SFP-SM+/LC EEC	943 947-001
M-FAST SFP-LH/LC	943 868-001
M-FAST SFP-LH/LC EEC	943 948-001
SFP-FAST-MM/LC <sup>a</sup>	942 194-001
SFP-FAST-MM/LC EEC <sup>a</sup>	942 194-002

Table 17: Accessory: Fast Ethernet SFP transceiver

<b>Fast Ethernet SFP transceiver</b>	<b>Order number</b>
SFP-FAST-SM/LC <sup>a</sup>	942 195-001
SFP-FAST-SM/LC EEC <sup>a</sup>	942 195-002

*Table 17: Accessory: Fast Ethernet SFP transceiver*

- a. You will find further information on certifications on the Internet on the Hirschmann product pages ([www.hirschmann.com](http://www.hirschmann.com)).

<b>Bidirectional Fast Ethernet SFP transceivers<sup>a</sup></b>	<b>Order number</b>
SFP-FAST-BA MM/LC EEC	942 204-001
SFP-FAST-BB MM/LC EEC	942 204-002
SFP-FAST-BA SM/LC EEC	942 205-001
SFP-FAST-BB SM/LC EEC	942 205-002
SFP-FAST-BA SM+/LC EEC	942 206-001
SFP-FAST-BB SM+/LC EEC	942 206-002

*Table 18: Accessory: Bidirectional Fast Ethernet SFP transceiver*

- a. You find further information on certifications on the Internet on the Hirschmann product pages ([www.hirschmann.com](http://www.hirschmann.com)).

<b>Gigabit Ethernet SFP transceiver</b>	<b>Order number</b>
M-SFP-TX/RJ45	943 977-001
M-SFP-SX/LC	943 014-001
M-SFP-SX/LC EEC	943 896-001
M-SFP-MX/LC EEC	942 108-001
M-SFP-LX/LC	943 015-001
M-SFP-LX/LC EEC	943 897-001
M-SFP-LX+/LC	942 023-001
M-SFP-LX+/LC EEC	942 024-001
M-SFP-LH/LC	943 042-001
M-SFP-LH/LC EEC	943 898-001
M-SFP-LH+/LC	943 049-001
M-SFP-LH+/LC EEC	942 119-001
SFP-GIG-LX/LC <sup>a</sup>	942 196-001
SFP-GIG-LX/LC EEC <sup>a</sup>	942 196-002

- a. You will find further information on certifications on the Internet on the Hirschmann product pages ([www.hirschmann.com](http://www.hirschmann.com)).

<b>Bidirectional Gigabit Ethernet SFP transceiver</b>	<b>Order number</b>
M-SFP-BIDI Type A LX/LC EEC	943 974-001
M-SFP-BIDI Type B LX/LC EEC	943 974-002
M-SFP-BIDI Type A LH/LC EEC	943 975-001
M-SFP-BIDI Type B LH/LC EEC	943 975-002
M-SFP-BIDI Bundle LX/LC EEC (Type A + B)	943 974-101
M-SFP-BIDI Bundle LH/LC EEC (Type A + B)	943 975-101
SFP-GIG-BA LX/LC EEC <sup>a</sup>	942 207-001
SFP-GIG-BB LX/LC EEC <sup>a</sup>	942 207-002
SFP-GIG-BA LX+/LC EEC <sup>a</sup>	942 208-001

<b>Bidirectional Gigabit Ethernet SFP transceiver</b>	<b>Order number</b>
SFP-GIG-BB LX+/LC EEC <sup>a</sup>	942 208-002
SFP-GIG-BA LH/LC EEC <sup>a</sup>	942 209-001
SFP-GIG-BB LH/LC EEC <sup>a</sup>	942 209-002

- a. You will find further information on certifications on the Internet on the Hirschmann product pages ([www.hirschmann.com](http://www.hirschmann.com)).

<b>Other accessories</b>	<b>Order number</b>
AutoConfiguration Adapter ACA22-USB (EEC)	942 124-001
Power Cord	942 000-001
Terminal cable	943 301-001
3-pin High Voltage Interlock terminal block (50 pcs.)	943 845-008
3-pin Low Voltage Interlock terminal block (50 pcs.)	943 845-011
2-pin terminal block for "Relay" signal contact	943 845-010
Bracket for fastening the housing	943 943-001
Bracket, long (+ 1.97 in (50 mm)), for fastening the casing (extra)	943 943-101
Protection cap for RJ45 socket (50 pieces)	943 936-001
Protection cap for SFP slot (25 pieces)	943 942-001
Network management software Industrial HiVision	943 156-xxx

## 7.9 Underlying technical standards

Name	
EN 61000-6-2	Electromagnetic compatibility (EMC) – Part 6-2: Generic standards – Immunity for industrial environments
EN 55032	Electromagnetic compatibility of multimedia equipment – Emission Requirements
IEC/EN 62368-1	Equipment for audio/video, information and communication technology - Part 1: safety requirements
EN 61131-2	Programmable controllers – Part 2: Equipment requirements and tests
EN 50121-4	Railway applications - EMC - emitted interference and interference immunity for signal and telecommunication systems
FCC 47 CFR Part 15	Code of Federal Regulations
Germanischer Lloyd	Rules for Classification and Construction VI-7-2 – GL
UL 508	Safety for Industrial Control Equipment
ISA-12.12.01	Nonincendive Electrical Equipment for Use in Class I and II, Division 2 and Class III, Divisions 1 and 2 Hazardous (Classified) Locations.
EN 61850-3	Communications networks and systems in stations
IEEE 1613	Standard Environment and Testing Requirements for Communication Networking Devices in Electric Power Substations
IEEE 802.1 D	Switching, GARP, GMRP, Spanning Tree
IEEE 802.1 Q	Media access control (MAC) bridges (includes IEEE 802.1p Priority and Dynamic Multicast Filtering, GARP, GMRP)
IEEE 802.1 Q	Tagging
IEEE 802.1 w	Virtual Bridged Local Area Networks (VLAN Tagging, GVRP)
IEEE 802.1 w	Rapid Reconfiguration
IEEE 802.3	Ethernet
EN 50155	Railway applications – Electronic equipment used on rolling stock

*Table 19: List of the technical standards*

The device has an approval based on a specific standard exclusively if the approval indicator appears on the device casing.

If your device has a shipping approval according to Germanischer Lloyd (GL), you find the approval mark printed on the device label. You will find out whether your device has other shipping approvals on the Hirschmann website at [www.hirschmann.com](http://www.hirschmann.com) in the product information.

# A Further support

## Technical questions

For technical questions, please contact any Hirschmann dealer in your area or Hirschmann directly.

You find the addresses of our partners on the Internet at <http://www.hirschmann.com>.

A list of local telephone numbers and email addresses for technical support directly from Hirschmann is available at <https://hirschmann-support.belden.com>.

This site also includes a free of charge knowledge base and a software download section.

## Hirschmann Competence Center

The Hirschmann Competence Center is ahead of its competitors on three counts with its complete range of innovative services:

- ▶ Consulting incorporates comprehensive technical advice, from system evaluation through network planning to project planning.
- ▶ Training offers you an introduction to the basics, product briefing and user training with certification.  
You find the training courses on technology and products currently available at <http://www.hicomcenter.com>.
- ▶ Support ranges from the first installation through the standby service to maintenance concepts.

With the Hirschmann Competence Center, you decided against making any compromises. Our client-customized package leaves you free to choose the service components you want to use.

Internet:

<http://www.hicomcenter.com>



**HIRSCHMANN**

---

A **BELDEN** BRAND